

## **Demystifying the Cloud Computing and Its Challenges**

**Prof. Neha Kanda\***

### **Abstract**

Cloud computing is a type of Internet-based computing, where shared resources, information, and data are given to PCs and different gadgets on-request. Cloud computing utilizes the internet advances for a conveyance of IT-release abilities 'as an administration' to any required clients i.e. through cloud computing we can get to anything that we need from anyplace to any PC without worried about anything like about their vault, cost, and administration. In this paper, I would toss light on the motivation variables of tolerating cloud computing, survey the few cloud sending and administration models. I likewise incorporate security, protection, and internet reliance and accessibility as evasion issues. It likewise investigates certain advantages of cloud computing over customary IT benefit environment-including versatility, flexibility, diminished capital and higher asset use are considered as appropriation explanations behind cloud computing environment. The later incorporates vertical adaptability as a technical challenge in cloud computing.

**Keywords:** - Cloud computing, Cloud services, Scalability, Virtualization, Vertical scaling.

### **I. Introduction**

Cloud Computing is a creative innovation that is changing the way we do computing. The key idea of cloud computing is that you don't purchase the equipment or even the product, you require any longer, rather you lease some computational power, stockpiling, databases, and some other asset you require by a supplier as indicated by a compensation as-you-go show, making your speculation littler and arranged to activities as opposed to resources securing. Yet, there is significantly more than that, obviously, and there is a wide range of ways how this approach can be placed in real life [1].

Cloud computing comprises of three particular sorts of computing administrations conveyed remotely to customers by means of the internet. Customers regularly pay a month to month or yearly administration expense to suppliers, to access frameworks that convey programming as an administration, stages as an administration and foundation as an administration to endorsers. Customers who buy in to cloud computing administrations can receive an assortment of rewards, contingent upon their specific business needs at a given point in time. The times of expansive capital interests in programming and IT framework are currently a relic of past times for any endeavor that receives the cloud computing model for obtainment of IT administrations [8]. The capacity to get to capable IT assets on an incremental premise is evening the odds for little and medium estimated associations, furnishing them with the fundamental apparatuses and innovation to contend in the worldwide commercial center, without the already imperative interest in on commencing IT assets. Customers who buy into computing administrations conveyed by means of the "cloud"• can enormously decrease the IT benefit uses for their associations;

---

\*Assistant professor & Research Scholar, Dept. of Computer Science & Applications, Guru Nanak National College, Nakodar, India

and access more light-footed and adaptable venture level computing administrations, all the while.

## II. Analysis Of Cloud Computing

Cloud computing offering which we can get the applications as utilities over the internet. It enables us to make, arrange, and customize the business applications online. Cloud Computing refers to controlling, designing, and getting to the equipment and programming assets remotely. It offers online information stockpiling, foundation, and application. Cloud computing offers stage independency, as the product isn't required to be introduced locally on the PC. Henceforth, the Cloud Computing is making our business applications mobile and community oriented.

## III. Architecture Of Cloud

Cloud computing architecture [2] comprises of several cloud mechanisms, which are heavily joined. We preserve generally separate the cloud architecture into two components:

- Front End
- Back End

Every of the ends are associated during a network, generally Internet. The subsequent figure 1. Shows the graphical analysis of cloud computing architecture:

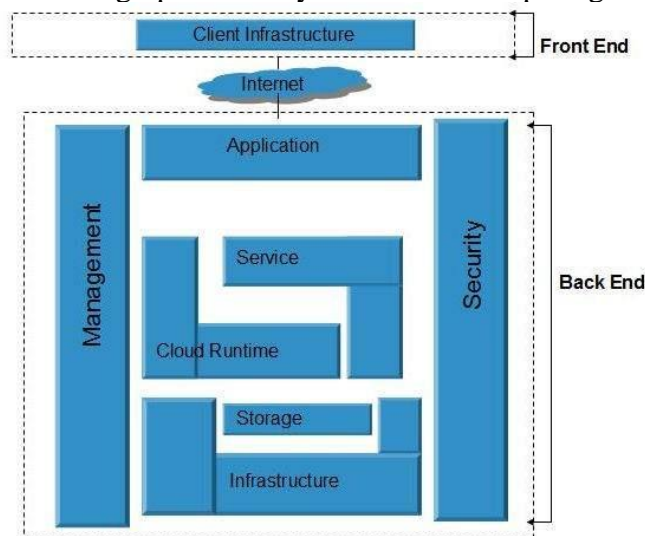

Figure 1 Architecture of Cloud

The **front End** refers to the customer part of cloud computing framework [2]. It comprises of interfaces and applications that are required to get to the cloud computing stages, Example - Web Browser.

The **back End** refers to the cloud itself. It comprises of the considerable number of assets required to give cloud computing administrations. It contains enormous information stockpiling, virtual machines, security instrument, administrations, sending models, servers, etc. It is the duty of the back end to give worked in security system; activity control and protocols. The server utilizes certain conventions known as middleware, which help the associated gadgets to speak with each other [2].

## IV. Cloud Service Models

Though service-oriented architecture advocates "everything as a service", cloud-computing providers offer their "services" according to different models, of which the three standard models per NIST are Infrastructure as a Service (IaaS), Platform as a Service (PaaS), and

Software as a Service (SaaS). These models offer increasing abstraction; they are thus often portrayed as layers in a stack: infrastructure-, platform- and software-as-a-service, but these need not be related. For example, one can provide SaaS implemented on physical machines (bare metal), without using underlying PaaS or IaaS layers, and conversely one can run a program on IaaS and access it directly, without wrapping it as SaaS [3-4].

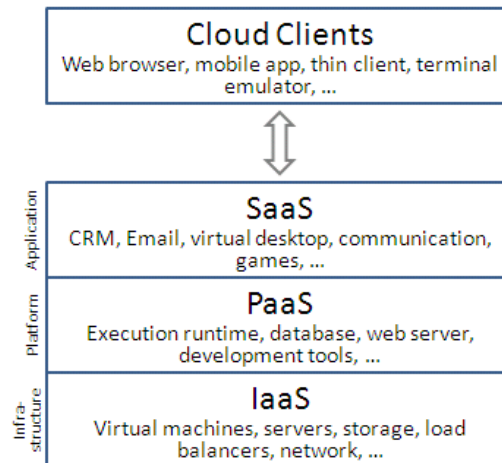

Figure 2 Cloud Service model

### 1. Software as a Service (SaaS)

These types of application are generally designed for end-users, delivered over the web. SaaS [6] works so much better for students because it provides access to applications anytime, anywhere, for any type of devices like laptop, smart phone, tablet, or other web-enabled device. Adding more users or scaling the software to more classrooms or campuses is becomes very easy task with SaaS. As an example, a college can scale its SaaS solution from 50 students to 5,000 in a matter of hours – unimaginable in the conventional IT scenario.

### 2. Platform as a Service (PaaS)

PaaS is the collection of development tools and services which is used for coding and deploying the applications quick and efficient [6]. With PaaS, Students, teachers or other academicians can develop new applications or services in the cloud which is platform independent, and also make them widely available to users through the Internet. It also provides services for testing, deploying, collaborating on, hosting, and maintaining applications.

### 3. Infrastructure as a Service (IaaS)

IaaS is the combination of hardware and software that powers it all – servers, storage, networks, operating systems. These are also known as On demand data centers which provide compute power, memory, and storage, typically priced per hour according to resource consumption. It can be used to satisfy the infrastructure needs of students, staff or any other academia's.

Cloud computing refers to the use of network of remote servers that are hosted over the Internet, and there are many cloud deployment and service models. The individual of the mainlyexclusiveindividuality of cloud computing is that the services since data storage to conception of software applications can be availed on pay-per-use basis [4-3].

## V. Cloud Deployment Models

The cloud sending models said underneath are based on the National Institute of Standards and Technologies. There are four essential cloud organization models [7], which are:

- **Private cloud model:** In this framework, the cloud foundation is set up on the preface for the restrictive utilization of an association and its clients. Regarding cost proficiency, this sending model doesn't bring numerous advantages. Be that as it may, numerous extensive ventures pick it due to the security it offers.
- **Public cloud model:** Public cloud is facilitated on the introduction of the specialist organization. The specialist organization than gives cloud administrations to the greater part of its clients. This sending is by and large embraced by numerous little to moderate sized associations for their non-center and a portion of their center capacities.
- **Community cloud:** Community cloud model is a cloud framework shared by a gathering of associations of comparative enterprises and foundations with comparable prerequisites i.e. mission, security, consistence and IT strategies. It might exist on or off commence and can be overseen by a community of these associations.
- **Hybrid cloud model:** Hybrid cloud is a blend of at least two models, private cloud, public cloud or community cloud. Despite the fact that these models keep up their different substances they are amalgamated through a standard innovation that empowers the movability of information and applications.

### Cloud Deployment Models

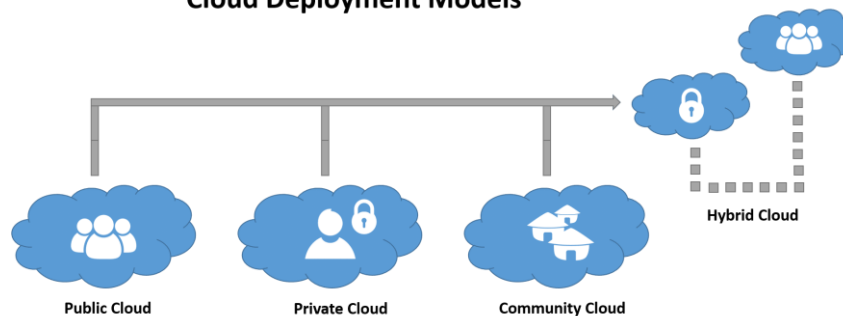

Figure 2 Cloud Deployment model

## VI. Cloud Computing Challenges

The present selection of cloud computing is related with various difficulties since clients are as yet wary about its authenticity [6]. The significant difficulties that keep Cloud Computing from being embraced are perceived by associations are as per the following:

- **Interoperability**

It implies the application on one stage ought to have the capacity to fuse administrations from alternate stages. It is made conceivable through web administrations, however growing such web administrations is exceptionally mind boggling.

- **Security and Privacy**

Security and Privacy of data is the greatest test to cloud computing. Security and privacy issues can be overwhelmed by utilizing encryption, security equipment and security applications.

- **Portability**

This is another test to cloud computing that applications ought to effectively be relocated starting with one cloud supplier then onto the next. There must not be vendor secure. In

any case, it isn't yet made conceivable in light of the fact that every one of the cloud suppliers utilizes distinctive standard dialects for their stages.

- **Computing Performance**

Information concentrated applications on cloud require high system bandwidth, which brings about high cost. Low bandwidth does not meet the coveted computing performance of cloud application.

- **Reliability and Availability**

It is fundamental for cloud frameworks to be solid and powerful in light of the fact that the greater part of the organizations are presently getting to be dependent on administrations gave by outsider.

## **VII Characteristics of Cloud Computing**

The following figure shows five essential characteristics that cloud computing offers for end users today and each is discussed below.

- **On-Demand Self Service**

On-demand self-service alludes to the service gave by cloud computing vendors that empowers the provision of cloud assets on demand at whatever point they are required [15]. The clients/consumers can singularly have provision to utilize computing power, stockpiling, networks and programming in a basic and adaptable way. Most clients start by utilizing restricted assets and increment them after some time. On-demand self-service approach approves clients to ask for assets on run time.

- **Broad Network Access**

Access to assets in the cloud is accessible over various gadget composes [10] which are PCs, workstations, mobile phones, tablets, workstations, thin customers, and so on. Assets are conserved by restricting the use which can be utilized based on need and essentialness of the workloads. Likewise, network assets were additionally rare. IP-based networks were not in predominant use four decades prior; consequently, access to pervasive high-bandwidth, low-dormancy networks did not exist. Later years, costs related with the network have diminished as a result of assembling versatility, commoditization of related advances, and competition in the commercial center. As network bandwidth has expanded, network access and adaptability have additionally expanded accordingly [11].

- **Resource Pooling**

The supplier's computing assets are pooled to serve various consumers utilizing a multi-inhabitant model in which different clients share nearby assets in the cloud with their companions, are the premise of public cloud frameworks. As per consumer demand, diverse physical and virtual assets are powerfully appointed and reassigned. There is a feeling of location independence in that the client for the most part has no control or information over the correct location of the gave resources but might have the capacity to indicate location at a more elevated amount of abstraction (e.g., nation, state, or datacenter). Cases of assets incorporate capacity, preparing, memory, and network bandwidth [19-20].

- **Rapid Elasticity**

The concept of rapid elasticity is one of the significant attributes that set cloud computing separated from traditional datacenter computing. Various inhabitants exist in a cloud environment that offers components of a common asset pool whereas on account of a private cloud, every one of the occupants is a piece of a solitary corporate element. Capacities can be flexibly provisioned and discharged, sometimes naturally, proportional



rapidly outward and internal comparable with demand i.e., occupants utilize the networking, register and capacity resources in the common pool, and then return them to the pool when they never again require those advantages. The very much architected cloud, the acquisition and arrival of benefits from and to the common pool would be robotized, based on service demands and driven by an insight policy [16].

- **Measured Service.**

In the undertaking, metering services additionally alluded to as "pay per utilize is a methods for responsibility. Metered services is important to the utility part of cloud computing. The real responsibilities of the service supplier are to be straightforward about the amount of the mutual framework a specific occupant utilizes, and the cost of that use. Asset utilization can be monitored, controlled, and detailed for both the supplier and consumer of the used service effectively and effortlessly. Cloud frameworks consequently control and improve asset use by utilizing a metering capacity at some level of abstraction fitting to the sort of service like stockpiling, handling, bandwidth, dynamicclient records and so on [19].

**Conclusion**

Cloud computing has several benefits over traditional (non- cloud) environment and has the capability to handle most sudden, temporary peaks in application demand on cloud infrastructures. Based on deployment and service, various cloud computing models are developed where each model serves differently to the end users. The initiation of cloud computing in current time has to glow a concern for diverse organizations, institution to take pros of web uses. These model promises the business/service organizations to show more interest to use resources pay per use/ buy or rent resources than investing more money with limited facilities. The characteristics of cloud computing, various deployment, and service-based cloud models are addressed in this paper. Despite having special features cloud computing is facing challenges to support interoperability, security, privacy, portability, computing performance, reliability, and availability efficiently are also discussed. Many people believe that Cloud will reshape the entire ICT industry as a revolution so it is becoming a more thrust area for researchers to find more services efficiently facing challenges.

**References**

- [1] Onur, E., Sfakianakis, E., Papagianni, C., Karagiannis, G., Kontos, T., Niemegeers, I., Chochliouros, I.P., de Groot, S.H., Sjodin, P., Hidell, Maliosz, M., Kaklamani, D.I., Carapinha, J., Belesioti, M., Fytros, E., —Intelligent End-To-End Resource Virtualization Using Service Oriented Architecture, Delft Univ. of Technol., Delft, Netherlands, GLOBECOM Workshops, IEEE, 28 December 2009.
- [2] Buyya R, "Market-Oriented Cloud Computing: Vision, Hype, and Reality of Delivering Computing as the 5th Utility," 9th IEEE International Symposium on Cluster Computing and the Grid, pp. 1, 2009.
- [3] G. Gruman, "What cloud computing really means", InfoWorld, Jan. 2009.
- [4] R. Buyya, Y. S. Chee, and V. Srikumar, —Market-Oriented Cloud Computing: Vision, Hype, and Reality for Delivering IT Services as Computing Utilities, Department of Computer Science and Software Engineering, University of Melbourne, Australia, pp. 9, July 2008.
- [5] C. Braun, M. Kunze, J. Nimis, and S. Tai.—Cloud Computing, Web-based Dynamic IT-Services". Springer Verlag, Berlin, Heidelberg, 2010.

- [6] S. Adabala, V. Chadha, P. Chawla, R. Figueiredo, J. Fortes, I. Krsul, A. Matsunaga, M. Tsugawa, J. Zhang, Mi. Zhao, L. Zhu, and X. Zhu. From virtualized resources to virtual computing Grids: the In-VIGO system. *Future Generation Comp. Syst.*, 21(6):896–909, 2005.
- [7] P. Barham, B. Dragovic, K. Fraser, S. Hand, T. L. Harris, A. Ho, R. Neugebauer, I. Pratt, and A. Warfield. Xen and the art of virtualization. In *Proceedings of the 19th ACM Symposium on Operating Systems Principles*, pages 164–177, New York, U. S. A., Oct.2003
- [8] F. Gens. (2009, Feb.). “New IDC IT Cloud Services Survey: Top Benefits and Challenges”, IDC eXchange, Available: [Feb. 18, 2010].
- [9] J. Brodtkin. (2008, Jun.). “Gartner: Seven cloud-computing security risks.” Infoworld, Available: [Mar. 13, 2009].
- [10] M. A. Morsy, J. Grundy and Müller I. “An Analysis of the Cloud Computing Security Problem” In *PROC APSEC 2010 Cloud Workshop*. 2010.
- [11] Cloud Security Alliance (CSA). Available: <http://www.cloudsecurityalliance.org> [Mar.19, 2010]
- [12] S. Arnold (2009, Jul.). “Cloud computing and the issue of privacy.” *KM World*, pp14-22. Available: [www.kmworld.com](http://www.kmworld.com) [Aug. 19, 2009].
- [13] A Platform Computing Whitepaper. “Enterprise Cloud Computing: Transforming IT.” *Platform Computing*, pp 6, 2010.
- [14] Global Netoptex Incorporated. “Demystifying the cloud.Important opportunities, crucial choices.” pp4-14. Available: <http://www.gni.com> [Dec. 13, 2009].
- [15] M. Klems, A. Lenk, J. Nimis, T. Sandholm and S. Tai. “What’s Inside the Cloud? An Architectural Map of the Cloud Landscape.” *IEEE Xplore*, pp 23-31, Jun. 2009.
- [16] C. Weinhardt, A. Anandasivam, B. Blau, and J. Stosser. “Business Models in the Service World.” *IT Professional*, vol. 11, pp. 28-33, 2009.
- [17] N. Gruschka, L. L. Iancono, M. Jensen and J. Schwenk. “On Technical Security Issues in Cloud Computing” In *PROC 09 IEEE International Conference on Cloud Computing*, 2009 pp 110-112.
- [18] N. Leavitt. “Is Cloud Computing Really Ready for Prime Time?” *Computer*, vol. 42, pp. 15-20, 2009.
- [19] S. Mahajan, S. Sharma, & Rana, V. “Design a Perception Based Semantics Model for Knowledge Extraction”. *International Journal of Computational Intelligence Research*, (2017). 13(6), pp. 1547-1556.
- [20] M. Jensen, J. Schwenk, N. Gruschka and L. L. Iacono, "On Technical Security Issues in Cloud Computing." in *PROC IEEE ICCS*, Bangalore 2009, pp. 109-116.

---

## **Soil Microarthropods in The Terine Forest Floors Of Northern Bengal- An Outline Overview**

**Niles Dasgupta\***

**Raja Routh\*\***

**Mahendra Chourasiya\*\*\***

### **Abstract**

Terine area of Northern part of West Bengal shows great diversity in terms of Flora and Fauna concerned as because it is situated in the Himalayan Foothills. Weather and climatic condition affects mostly over the long period of time. We restricted our study mainly in two forest floor area under Baikunthapur Forest Division situated in Jalpaiguri District and Mahananda Wildlife Sanctuary in Darjeeling District. We collected samples randomly from three site of our study area. Microarthropods plays vital role in the area affecting Micro Edaphic Environment at the study area. Climatic condition, Soil types and variation in vegetation in the area may affects over their population and variation. Decomposition by Microarthropods of Organic debris controls the nutrient cycles of the soil. Microarthropods may vary at the forest floor of Terine area in Northern Bengal. Collected 36 bags of sample containing 220 Microarthropods reveals that the Northern most portion of Terine Forest harbours highest species Diversity (Shannon-Weaver index) while Southern part shows lowest value. Site-III shows more diversity in comparison to other Site. Further more, Southern portion shows highest species richness (Menhinick's index). Out of three study area plot the Northern Plot shows highest level in terms of Diversity. Variation in Edaphic factors may responsible for their diversity.

**Key Words:** Microarthropod, Diversity, Terine, Forest, Climatic condition, Debris, Edaphic Factor

### **Introduction**

Terine area of Northern Bengal has varieties of different type's flora and fauna. Microarthropods play a very crucial role in the variation of physiochemical properties of Micro Edaphic Environment. They are considered as the important degrading factors of soil debris. Their ecological role significantly concerns with the fertility of soil by the process of decomposition of organic debris and nutrient cycling (Heneghan et al. 1998; Coleman and Crossley, 2004).

In fact our present study was taken up to assess the diversity scenario in soil microarthropods communities dwelling Terine forest floors of northern parts of Bengal.

### **Materials and Methods**

**Sampling:** We collected at three different forest floors (site-I, site-II, and site-III) with more or less similar vegetation's, along three 5m strips, adjacent to the road side during the four seasons (summer, monsoon, post-monsoon, winter) from April 2015 to March 2016.

---

\*Bhotepatty H.B.L.High School, Jalpaiguri,W.B.

\*\*Department of Zoology, Sambu Nath College, LabPur, Birbhum,W.B.

\*\*\*Department of Zoology, Swami Vivekanand University,Sagar,M.P.



We collected soil and litter together with a shovel (Chattopadhyay and Hazra, 2000; Sanyal et al., 2006) and kept in plastic bags for carrying them to college laboratory.

Three bags of soil and litter each of about 500cc volume was collected from every site during the mentioned season.

#### **Collection site**

Site-I (26o39/11.47// N, 88o37/11.96// E) was located at Bodaganj forest, Under the Gourikone Beat of Baikunthapur Forest Division situated in Jalpaiguri District at the northern part of West Bengal. It is approximately 22 km away from Jalpaiguri town and surrounded by a sparsely populated area. Deforestation is the main challenges in this area and remains under tremendous pressure of anthropogenic activity. Site-II was located at the periphery zone of Baikunthapur Forest Division adjacent to the canal road while the site-III (26o48/29.32//N, 88o20/57.34//E) was located at southern part of Sukna Range under Mahananda Wildlife Sanctuary situated some 60 km from Jalpaiguri District Town.

Distinctly 3 seasons prevails here i.e., summer, Monsoon and winter. Major flora such as *Shorea robusta* (Sal), *Tectona grandis* (Segun), *Anthocephalus cadamba* (Kadam), *Mangifera indica* (Mango), *Syzygium cumini* (Jamun), *Michelia champaca* (Champa), *Artocarpus heterophyllus* (Jack Fruit), *Ficus carica* (Fig), etc. were predominant in the site. *Lantana camera* (Shrub), *Dryopteris sp.* (Fern) etc. were predominant as ground vegetation at the sites.

#### **Extraction**

We extracted soil microarthropods using Berlese-Tullgren funnels (Rohitha, 1992; Lakly & Crossley, 2000). The process was run for 4-5 days for each sample set up depending upon the condition of the soil. Microarthropods extracted was collected and preserved in 80% alcohol (Ghosh, 1986; Gupta, 1986).

#### **Sorting and preservation**

First of all extracts were transferred part by part on a Petri dish and microarthropods were sorted from the extract using needles and fine camel (No.'00') hair brush under a dissecting microscope (with 32x magnification). Finally Separated micro arthropods were kept in Eppendorf tubes containing 80% alcohol.

Basically Identification of arthropods was done up to order level only, for estimation of diversity.

**Analysis:** Group diversity was calculated using Shannon's Index following Cancela da Fonseca and Sarkar (1998). More than one approach appears necessary to assess a community as there is no unanimous view as which diversity index may satisfy all aspects (Magurran, 1988). Indices used in the present study were -Shannon index of diversity (Shannon and Weaver, 1963) and Richness (Menhinick, 1964).

#### **Results and Observations**

In fact 36 bags of litter and soil were collected from three sites. Total 220 soil microarthropods were extracted from these sites. Highest abundance of micro arthropods was recorded at site-III while lowest abundance was observed at site-II (Table 1).

At site-II Diptera larvae were the most abundant group, while Oribatid mites constituted the most numerous group at sites-II and III (Table 1, Figure 2).

At site-I, Oribatida was the most abundant order constituting 32.65% (16 out of 49) of the total collection, followed by Diptera 24.49% (12 out of 49). Other mites and collembolans collectively shared 57.14% of the total population. (Table 1, Fig.2)

At site-II, Diptera constituted 38.64% (17 out of 44) of the total collection. Oribatid mites and Coleopterans each exhibited 22.73% (10 out of 44) and 20.45% (9 out of 44) relative abundance respectively (Table 1, Fig.3)

At site-III, Oribatida shared 37.01 % (47 out of 127) of total population, followed by Diptera 18.9% (24 out of 127). Other mites and Collembolans collectively shared 55.9%0 of the total collection (Figures 2, 3, 4).

Diversity index (Shannon and Weaver, 1963) was highest at site-III and lowest at site-II (Fig.5). Species richness (Menhinick, 1964) is highest at Site -I.

	Site-I	SITE-II	Site-III
Oribatid Adult	9	6	36
Oribatid Larva	7	4	11
Mesostigmata Nymph	4	2	14
Prostimata	2	1	1
Astigmata	0	0	1
Collembola	6	2	24
Protura	0	0	1
Diplura	0	0	1
Simphyla	3	1	0
Coleoptera Larva	6	8	12
Coleoptera Adult	0	1	0
Diptera Larva	12	17	24
Hymenoptera	0	2	1
Aranae	0	0	1
<b>Total</b>	<b>49</b>	<b>44</b>	<b>127</b>

**Table 1: Abundance of different groups of collected soil microarthropods**

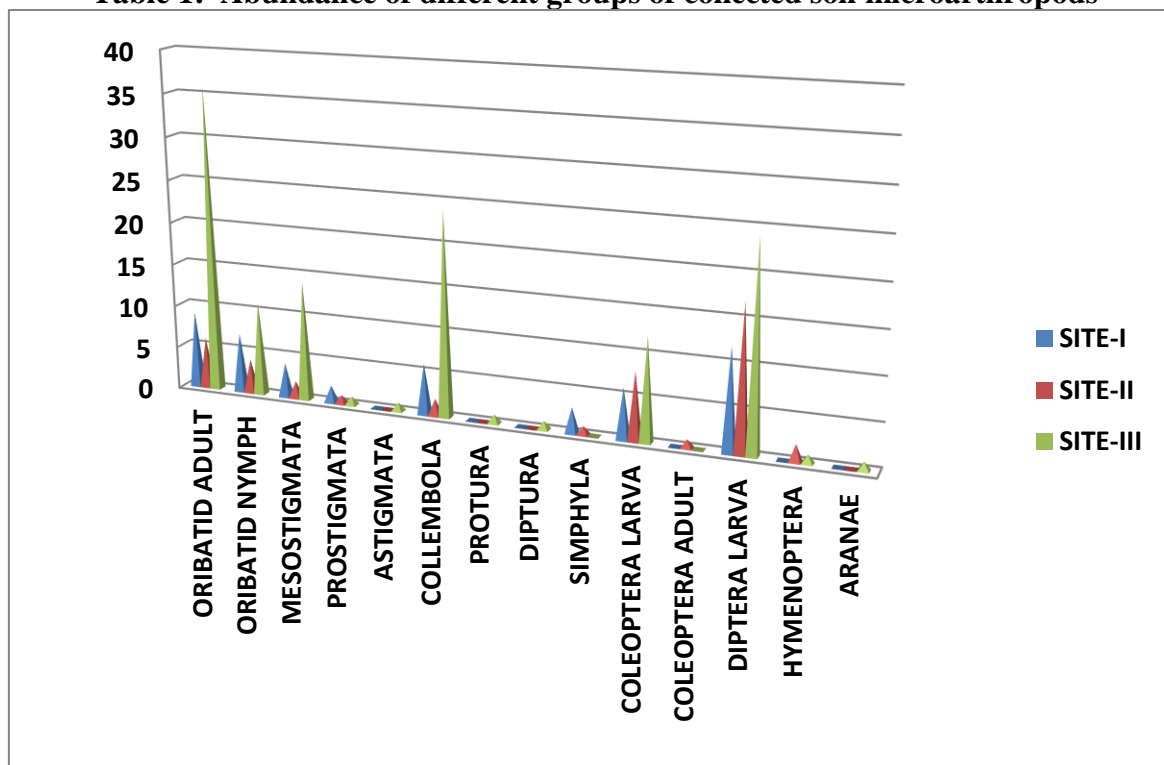

**FIGURE 1: SHOWS ABUNDANCE OF DIFFERENT MICROARTHROPOD GROUPS AT COLLECTION SITE**

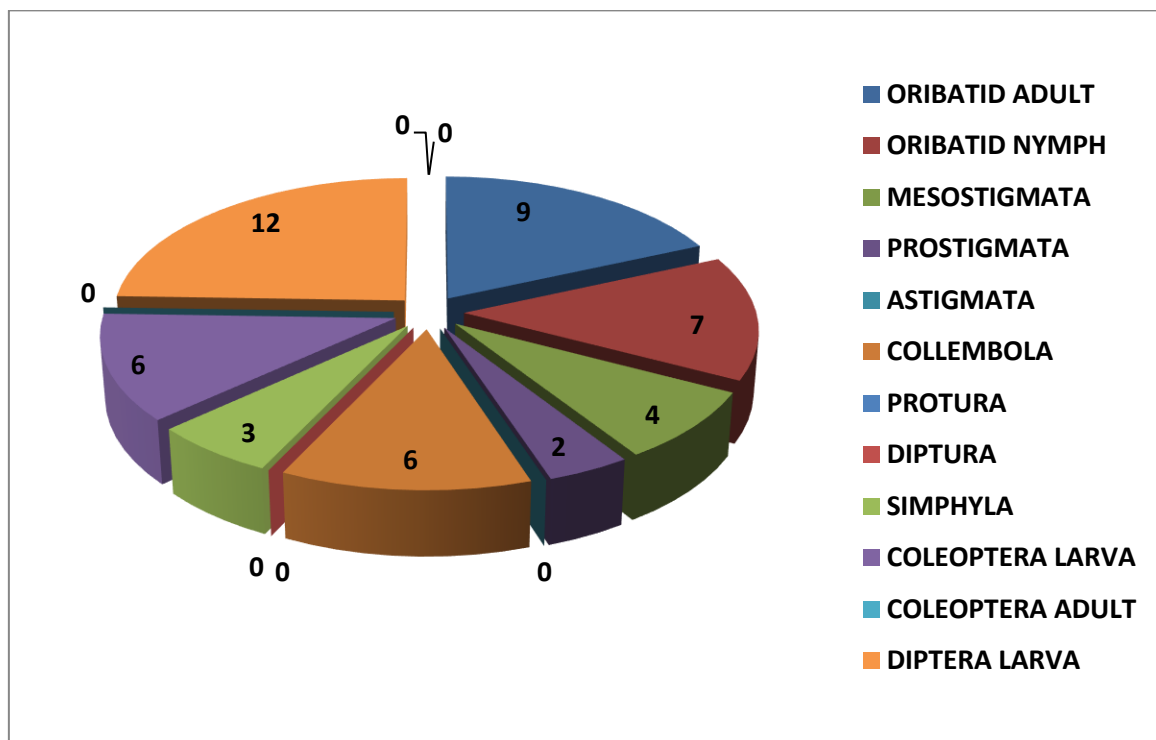

**FIGURE 2: SHOWS ABUNDANCE OF DIFFERENT MICROARTHROPOD GROUPS AT SITE-I**

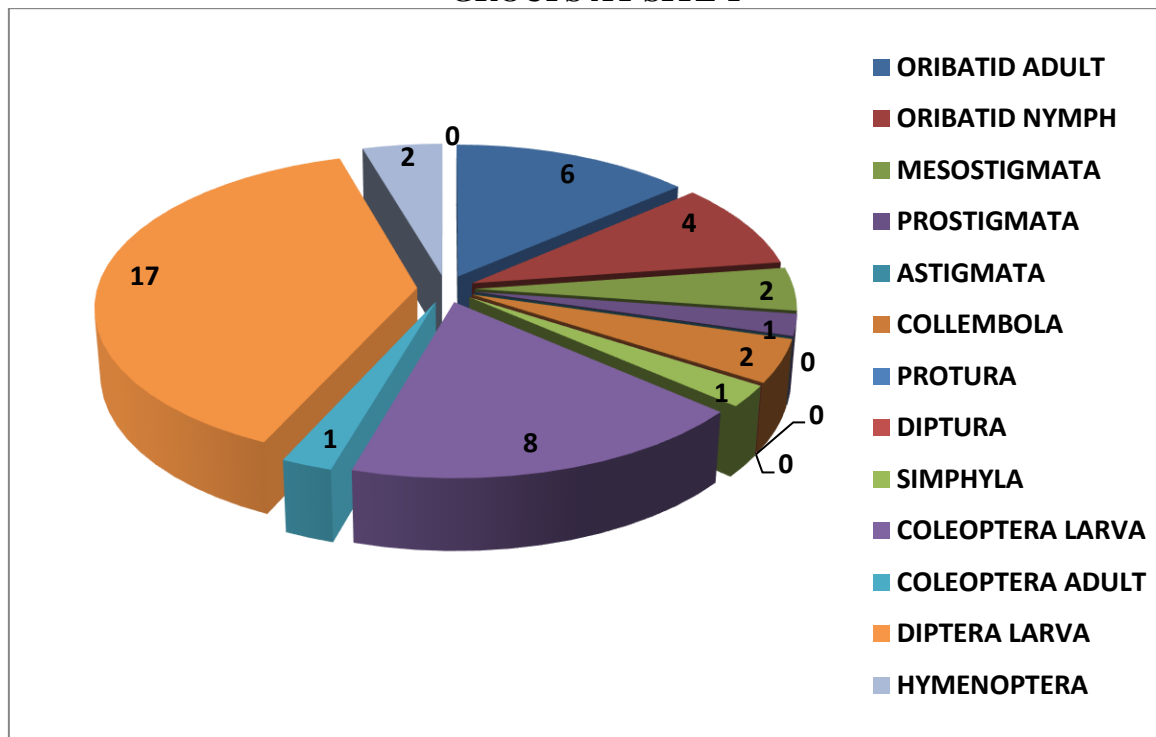

**FIGURE 3: SHOWS ABUNDANCE OF DIFFERENT MICROARTHROPOD GROUPS AT SITE-II**

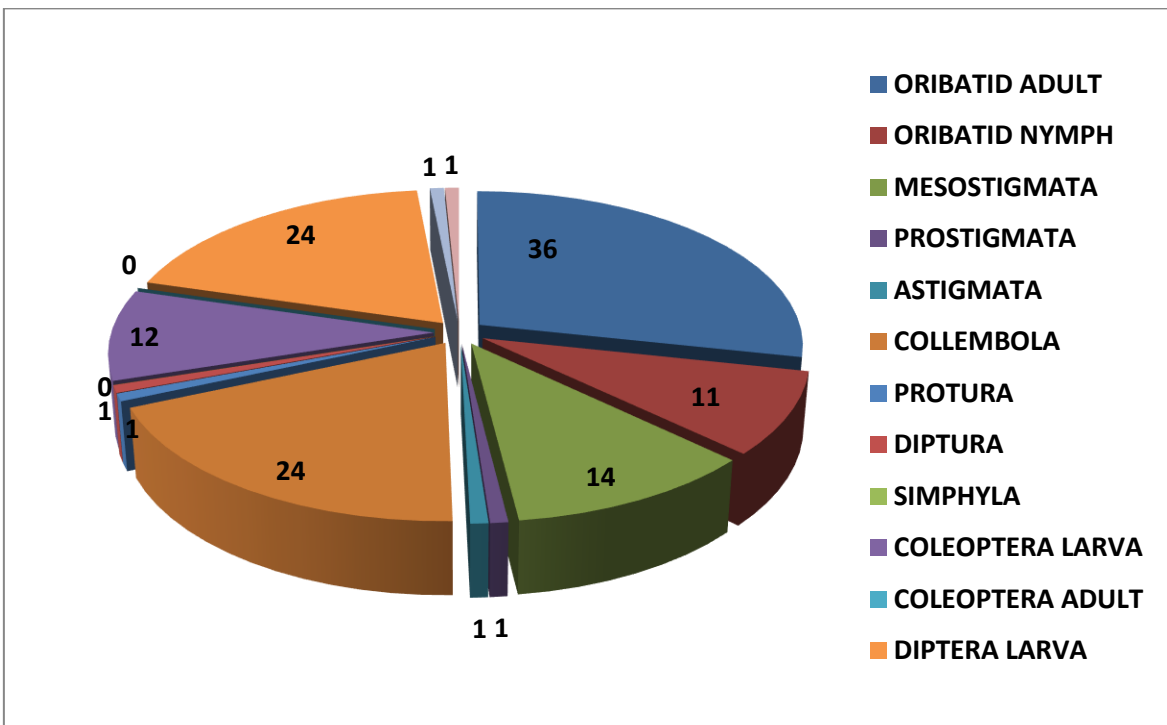

FIGURE 4: SHOWS ABUNDANCE OF DIFFERENT MICROARTHROPOD GROUPS AT SITE-III

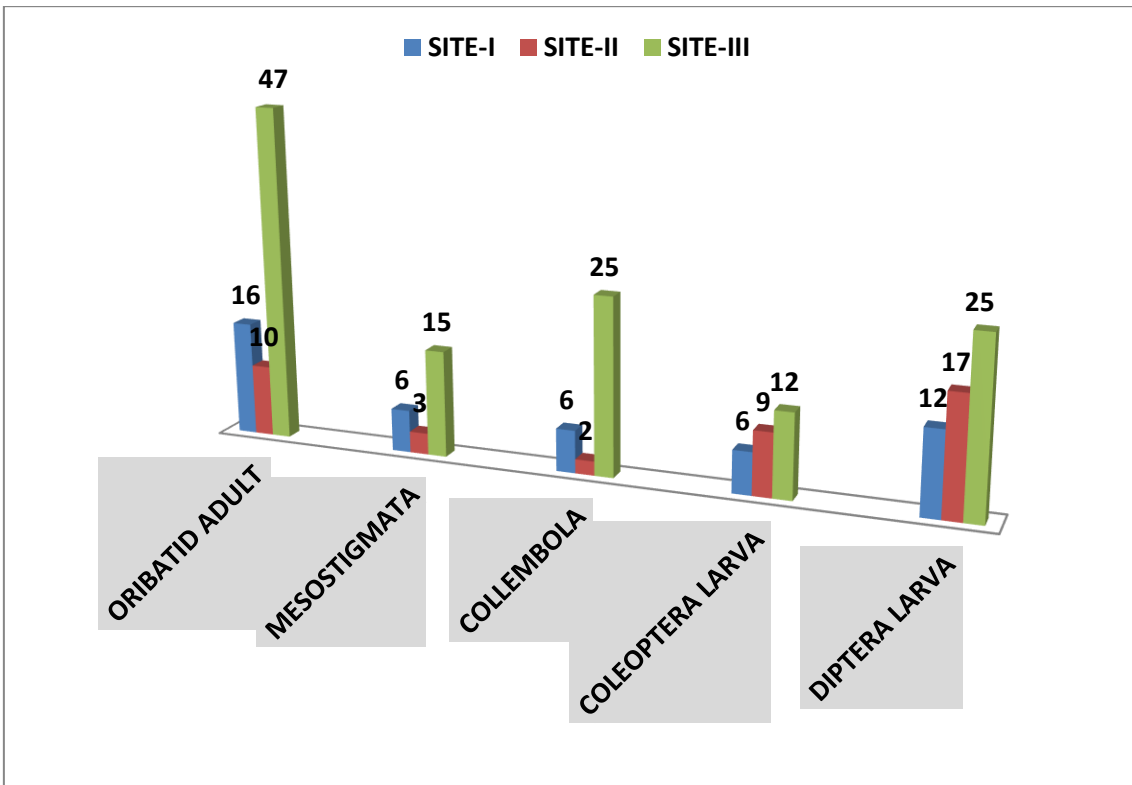

FIGURE 5: SHOWS ABUNDANCE OF DIFFERENT MICROARTHROPOD GROUPS (ADULT AND LARVA) AT COLLECTION SITES DISCUSSION

Practically unclear gradient in terms of diversity and abundance of micro arthropods from north to south was noticed in the study area. The site located at Bodaganj (site-I) exhibited greater abundance and diversity in comparison to the site located in the periphery of Baikunthapur Forest (site-II). Site-III located at the Sukna Range of Mahananda Wildlife Sanctuary which shows highest diversity and abundance in microarthropod communities among the sampling sites. The Greater density of large trees, diverse ground vegetation, relatively less disturbance in this site might have favored microarthropod communities here.

Site-II showed relatively less abundant and diverse microarthropod communities probably due to the poor occurrence of trees at this site. Trees generally provide shadow which supports moist environment even in sunshine; supply thick litter and favors fungal growth. All these collectively create favorable condition for microarthropods.

Species richness was highest at site-I though the diversity index was highest at site-III. This observation probably indicates remarkable variation in micro-environmental factors in the area.

### **Conclusion**

Tremendous pressure of anthropogenic activities appeared to have some impact on micro arthropods diversity and abundance in the study area. Periphery of Baikunthapur Forest Division exhibits the least diversity. The probable reason is that the site is located adjacent to the motorable roadway with vehicular activity.

Any gradient, however, was not established probably due to variation in micro-environmental factors.

At the end we concluded that further study is required to investigate the actual scenario of the region.

### **Acknowledgement**

Authors are thankful to concerning Forest Divisions and their staffs for their kind cooperation during entire study. We also thankful to the local Panchayets and Forest villagers for their whole hearted support. We express our deep concern to Local Laboratories and Institutions for extending their continuous assistance time to time whenever required.

### **References**

1. Cancela da Fonseca JP, Sarkar S. 1998. Soil microarthropods in two different managed ecological systems (Tripura, India). *Applied Soil Ecology*, 9: 105-107.
2. Chattopadhyay, A. and Hazra, A. K. 2000. Effects of heavy metal contaminated sewage effluents on the soil arthropods in and around Kolkata. *Rec. Zool. Surv. India, Occ. Paper No. 186*: 1-109.
3. Coleman, D. C., Blair, J. M., Elliott, E. T., and Wall, D. H. 1999. *Soil Invertebrates*. In: *Standard Soil Methods for Long-Term Ecological Research*. Oxford University Press, Oxford, New York, pp. 349-377 (Eds. G. Philip Robertson, David C. Coleman, Caroline S. Bledsoe, and Phillip Sollins).
4. Coleman, D. C., Crossley D. A., Hendrix, P. F. 2004. In: *Fundamentals of soil ecology*, Elsevier academic press, Burlington, USA, pp. 386.
5. Crossley, D.A. (Jr.) and Coleman, D. C. 1999. *Microarthropods*. In: *Handbook of Soil Science* CRC Press, Boca Raton. pp. C-59 - C-65 (Ed. Malcom E. Sumner).
6. Curry, J.P., Momen, F. 1978. The arthropod fauna of grassland on reclaimed cutaway peat in Central Ireland. *Pedobiologia*, 32: 99-109.



7. Fenton, G. R. 1947. The soil fauna with special reference to the ecosystem of forest soil. *J. Anim. Ecol.*, 16:76-93.
8. Ghosh, A. 1986. Collection and preservation of arthropods. In: Manual: collection, preservation, and identification of insects and mites of economic importance. Zoological Survey of India, MOEF, Kolkata.
9. Gupta, A. K. 1986. Collection and preservation of mites. In: Manual: collection, preservation, and identification of insects and mites of economic importance. Zoological Survey of India, MOEF, Kolkata.
10. Heneghan, L. Coleman, D.C., Zoub, X., Crossley, D.A.(Jr), Hainesc, B. L. 1998. Soil microarthropod community structure and litter decomposition dynamics: A study of tropical and temperate sites. *Applied Soil Ecology*, 9: 33-38.
11. Lakly, M.B. & Crossley, D.A. Jr. (2000) Tullgren extraction of soil mites (Acarina): Effect of refrigeration time on extraction efficiency. *Experimental and Applied Acarology*, 24, 135-140.
12. Menhinick, E.F. 1964. A comparison of some species diversity indices applied to samples of field insects. *Ecology*, 45: 859-861.
13. Oliver I. and Beattie A.J. 1993. A Possible Method for the Rapid Assessment of Biodiversity. *Conservation Biology* 7: 562–568.
14. Oliver I. and Beattie A.J. 1996a. Designing a cost-effective invertebrate survey: a test of methods for rapid assessment of biodiversity. *Ecological Applications* 6: 594–607.
15. Oliver I. and Beattie A.J. 1996b. Invertebrate morphospecies as surrogates for species: a case study. *Conservation Biology* 10: 99–109.
16. Rees C.J.C. 1983. Microclimate and the flying Hemiptera fauna of a primary lowland rain forest in Sulawesi. In: Sutton S.L., Whitmore T.C. and Chadwick A.C. (eds), *Tropical Rainforest: Ecology and Management*. Blackwell, Oxford, UK, pp. 121–136.
17. Rohitha, B.H. (1992) A simple separation system based on flotation for small samples of insects contaminated with soil. *New Zealand Entomologist*, 15, 81-83.
18. Sanyal, A. K., Sarkar, B. J. and Moitra, M. N. 2006. Oribatid mites (Acari: Oribatei). Fauna of Arunachal Pradesh, State fauna Series, *Zool. Surv. India.*, 13 (2): 467 – 478.
19. Shannon, C.E. and Weaver, W. 1963. In: *The mathematical theory of communication*. University of Illinois Press, Urbana. pp. 1-117.
20. Simpson, E. H. 1949. Measurement of diversity. *Nature*, 163: 688.
21. Whittaker, R.H. 1960. Vegetation of the Siskiyou Mountains, Oregon, and California. *Ecol. Monogr.* 30: 279-338.

## **An Accompaniment to Biodegradable Packaging Film Incorporated With Licorice Root Extract**

**Divya Yadav\***

**Divya Puri\*\***

**Mahak Sharma\*\*\***

### **Abstract**

The present study aimed at developing a packaging film incorporated with licorice root extract. The innovation behind using licorice root extract was to explore its properties in food packaging sector, rather than its conventional usage in the pharmaceuticals and cosmetic industries. Two film samples i.e. test sample and control sample were prepared. The test film sample was made using Tween 80, PEG (polyethelene glycol), food grade pectin, water and licorice root extract and the control sample was not incorporated with licorice root extract and only prepared with Tween 80, PEG, food grade pectin and water. The films were standardized using different formulations. Both the films were subjected to physical tests. The test showed that the films were biodegradable in nature since Tween 80 and PEG also helps in enhancing the biodegradable properties of the film.

**Keywords:** Biodegradable packaging, licorice root extract, PEG, Pectin.

### **Introduction**

#### **Biodegradable Packaging**

Biodegradable films are designed with the intention of replacing the polyethylene film used for different purposes, from various industrial films, packaging products to the bag for the collection of organic waste. Such materials have better properties than traditional non-degradable plastics. They are resistant to moisture, warm organic materials for a period of several weeks or even months without changes in physical properties. This allows greater flexibility composting program. Good as a replacement for current films used in storage, transport and packaging of the product and are completely biodegradable. In addition, do not contain polyethylene, do not leave residues after composting and are made from renewable biomaterials (polyester derived from corn dextrose). A comparative study of the permeability of the biodegradable film for oxygen and carbon dioxide as a form of packaging for the fruit of tomatoes showed that films with low permeability negatively affected the quality of the fruit. However, when the permeability of the biodegradable films is into line with the respiration of the fruit, the prevention of contamination by microorganisms and insects achieved a positive effect on the durability and quality (Muratore et al, 2005). Compared with polyphenol foil, biodegradable film permeability is significantly decreased. Two kinds of experimental films have been applied to freshly chopped pineapple and melon and observed for their influence on the microbiological quality control of the fruit during storage at 10 °C. The types of films that were used in this study are commercial plastic stretch film and experimental methyl-

---

\* Student, Manav Rachna International Institute of Research & Studies, Faridabad, Haryana, India

\*\*Assistant Professor, Manav Rachna International Institute of Research & Studies, Faridabad, Haryana, India

\*\*\*Associate Professor, Manav Rachna International Institute of Research & Studies, Faridabad, Haryana, India

cellulose film that includes vanilla as a natural antimicrobial agent. Fresh sliced fruit, without any foil wrapping was used as a control. Methyl-cellulose film had inhibitory effect against *Escherichia coli*, and the yeast was reduced was recorded. Methyl cellulose films with vanillin increased the intensity of the yellow color with pineapple. Pineapple which was guarded in an ordinary commercial plastic film had a larger amount of ethanol. However, with pieces of pineapple coated biodegradable film with vanillin recorded a decrease of ascorbic acid by 90 % (Sungsuwan et al, 2008).

Active Packaging is very popular recently and will gradually revolutionize the packaging industry. Active packaging are of different types named as, Bio-Chemical active films, Antimicrobial packaging, Oxygen, CO<sub>2</sub>, Gas-scavenging, Moisture control, Anti-Oxidation, Temperature Controlled Packaging, Active labels and indicators and Nano-technology enabled packaging (Karleigh Huff 2015). Active packaging is accurately defined as “packaging in which subsidiary constituents have been deliberately included in or on either the packaging material or the package headspace to enhance the performance of the package system (Robertson, 2006). This phrase emphasizes the importance of deliberately including a substance with the intention of enhancing the food product. Active packaging is an extension of the protection function of a package and is commonly used to protect against oxygen and moisture.

Active packaging systems are developed with the goal of extending shelf life for foods & increasing the period of time that the food is high quality. Active packaging technologies include some physical, chemical, or biological action which changes interactions between a package, product, and/or headspace of the package in order to get a desired outcome (Yam et al., 2005).

In particular, a first classifications of active systems can be made, according to their functionality, in absorbers or scavenger systems (Lopez Rubio, 2004; Labuza, 1989; Vermeiren, 1999; Brody, 2001), releasing or emitter systems (Lopez-Rubio, 2004; Vermeiren, 1999; Ahvenainen, 2003) and active systems based on the energy transport (Xia, 2008; Benim, 2007).

### **Licorice**

*Glycyrrhizaglabra*, family Leguminosae, is a plant which grows in Egypt and other countries of the world. Its roots possess some nutritive value and medicinal properties. *Glycyrrhiza glabra* Linn, a commonly used herb in ayurvedic medicine. Studies indicate that *Glycyrrhiza glabra* Linn possesses antibacterial, antioxidant, antimicrobial, antispasmodic, anti-inflammatory and anti hyper glycaemic properties. Various other effects like antiulcer, antiviral, antihepatotoxic, antifungal and herpes simplex have also been studied. They are widely used as a cold beverage, in preparing some pharmaceutical preparations such as haematinic pills and to disguise the bitter taste of other remedies (Fenwick et al., 1990). *Glycyrrhiza glabra* Linn is one of the most widely used herb from the ancient medical history of Ayurveda, both as a medicine and also as a flavouring herb. It is a very sweet, moist, soothing herb that detoxifies and protects the liver and is also a powerful anti-inflammatory, being used in conditions as varied as arthritis and mouth ulcers. *Glycyrrhiza glabra*, also known as licorice and sweet wood, is native to the Mediterranean and certain areas of Asia. Historically, the dried rhizome and root of this plant were employed medicinally by the Egyptian, Chinese, Greek, Indian, and Roman civilizations as an expectorant and carminative. In modern medicine, licorice extracts are often used as a flavouring agent to mask bitter taste in preparations, and as an expectorant

in cough and cold preparations. Licorice extracts have been used for more than 60 years in Japan to treat chronic hepatitis, and also have therapeutic benefit against other viruses, including human immunodeficiency virus (HIV), cytomegalovirus (CMV), and Herpes simplex. Deglycyrrhizinated licorice (DGL) preparations are useful in treating various types of ulcers, while topical licorice preparations have been used to soothe and heal skin eruptions, such as psoriasis and herpetic lesions.

### **Material and Methods**

The study was carried out in the following four phases:

- Procurement of Raw materials
- Film Preparation
- Physical Test of Packaging Films
- Statistical Analysis

#### **Phase 1: Procurement of Raw Materials**

This phase consisted of procurement of raw materials from the market. The licorice roots and food grade pectin were collected from local market of Faridabad, India. The chemicals named Polyethylene Glycol (PEG) and Tween 80 were collected from Liberty chemicals shop situated in Delhi.

#### **Phase 2: Film Preparation**

##### **Formation of Licorice Extract**

This phase fore mostly consisted of licorice root extract formation followed by film formation using the same extract. Licorice roots were collected and dried in shade at room temperature. After complete drying, these roots were powdered in an electric blender. 10g of licorice root powder was then mixed with 300 ml water and heated at 60<sup>0</sup>C under constant stirring for 4 hours. After cooling down, the solution was filtered using a strainer. Finally the licorice root extract was stored in refrigerator at 4<sup>0</sup>C film preparation.

##### **Film Formation**

The test film was formed using combination of following ingredients: 2.5g Pectin + 2ml Tween 80 + 8g PEG 400 + 78.5ml water + 9ml licorice root extract (9.8%). The above ingredients were mixed properly and stirred for half an hour using a magnetic stirrer. The solution was then poured over a ceramic tile and kept for drying at room temperature for 24 hours. The dried films were cut, peeled from the casting surface and stored wrapped in butter paper within air-tight sealed plastic bags. The control film was prepared using the same ingredients, except licorice root extract.

#### **Phase 3: Physical Test of Packaging Films**

##### **Flame Test**

The sample was held at the edge of a flame. If no flame is produced quickly, hold the sample in the flame for about 10 seconds. If the material burns, note the color of the flame, the nature of the smoke, the presence of soot in the air and whether, while burning, the sample drips. Next, extinguish the flame and cautiously smell the fumes. To identify the odor, samples of known plastic samples for comparison can be most helpful. Finally, check your observations against the known characteristics of each plastic. The test was repeated thrice for each sample [ASTM 1980].

##### **Biodegradability Test**

Film samples were buried in soil, or performing a full-scale composting process with the biodegradable plastic, represent the ideal practical environmental conditions

### Solubility Test

The film solubility in water was determined according to the method reported by Casariego et al., 2009. Four rectangular pieces (7.5 mm × 15 mm) were cut from each film and dried under vacuum in an oven at 105 °C and 35 kPa for 24 h (to a constant weight) to determine the initial dry weight and then the films were immersed in 50 mL of water at 20 °C with occasional agitation. After 24 h of immersion, the specimens of films were recovered by gently rising with distilled water and then dried to constant weight (105°C). The measurement of films solubility was determined as follow

$$\text{solubility (\%)} = \frac{M_i - M_f}{M_i} \times 100$$

Where;  $M_i$  - initial mass of the sample

$M_f$  -final mass of the sample

### Results and Discussion

The study was conducted in three phases, which are as under:

#### Phase I: Procurement of Raw Materials

The raw materials like licorice roots and food grade pectin were collected from local market of Faridabad, India. The chemicals named Polyethylene Glycol (PEG) and Tween 80 were collected from Liberty chemicals shop in Delhi.

#### Phase II: Film Formation

The film was formed just by extraction of licorice root extract followed by film preparation.

#### Extraction of Licorice Root Extract

Licorice roots were collected and dried in shade at room temperature. After complete drying, these roots were powdered in an electric blender. 10g of licorice root powder was then mixed with 300 ml water and heated at 60°C under constant stirring for 4 hours. After cooling down, the solution was filtered using a strainer. Finally the licorice root extract was stored in refrigerator at 4°C for future use.

#### Film Preparation

The film was formed using combination of following ingredients 2.5g Pectin + 2ml Tween 80 + 8g PEG 400 + 78.5ml water + 9ml licorice root extract (9.8%)

The above ingredients were mixed properly and stirred for half an hour using a magnetic stirrer. The solution was then poured over a ceramic tile and kept for drying at room temperature for 24 hours. The dried films were cut, peeled from the casting surface and stored wrapped in butter paper within air-tight sealed plastic bags. And a control film was prepared using 2.5g Pectin, 2mL Tween 80, 8g PEG 8000, 88.5mL water was prepared.

#### Phase III: Physical Tests

The physical analysis of the biodegradable packaging film (BPF) comprised of the following tests:

**Flame Test:** The flammability test is used to determine the relative rate of burning of self-supporting plastics. This test is mainly used for quality control, production control and



material comparisons. For quality control, production control and material comparisons, it cannot be used as a criterion for fire hazard.

The flame was of orange colour with slow speed of drip with good scratch able properties for films enriched with licorice root extract. For the control sample with no extract, the flame was of orange colour with moderate drip speed with good scratch able properties. The odour was same like paraffin for both the samples and average time taken for a film of 15 sec. The parameters were checked in accordance with (Nunmer, Trombetta et al., 2012). The residue of films after burning was black in colour.

**Table 1: Flame Test Results of Packaging Films**

SAMPLE	ODOUR	DRIP	DRIPPING SPEED	COLOUR OF FLAME	TIME
A	Paraffin	Yes	Moderate	Orange	15 secs
B	Paraffin	Yes	Slow	Orange	15.7secs

\* Values are represented as Mean  $\pm$ SD of triplicate determination, Sample-A: Control (i.e. packaging film without licorice root extract) and Sample-B: Test Sample (i.e. packaging film with licorice root extract)

**Biodegradability Test:** The films were buried in soil for about a week to check the biodegradability of films. The term biodegradable plastics normally refer to an attack by microorganisms on no water soluble polymer-based materials (plastics). This implies that the biodegradation of plastics is usually a heterogeneous process. Because of the lack of water solubility and the size of the polymer molecules, microorganisms are unable to transport the polymeric material directly into the cells where most biochemical processes take place; rather, they must first excrete extracellular enzymes which depolymerise the polymers outside the cells (Joachim et al., 2014). The test film was found to be biodegradable (since no residues were reported) whereas the control film showed residues, indicating its non-biodegradable nature.

**Table 2: Biodegradability Test Results of Packaging Films**

PARAMETER	SAMPLE-A	SAMPLE-B
Biodegradability Test	Negative	Positive

\* Values are represented as Mean  $\pm$ SD of triplicate determination, Sample-A: Control (i.e. packaging film without licorice root extract) and Sample-B: Test Sample (i.e. packaging film with licorice root extract)

**Film Solubility Test:** Both the films (i.e. control and test sample) were completely soluble in water. The films were kept for 24 hours in water. After 24 hours no residue was found in either of the samples, which indicated that both the packaging film samples (i.e. control and test sample) were soluble in water (Table 3).

**Table 3: Film Solubility Test Results of Packaging Films**

PARAMETER	SAMPLE-A	SAMPLE-B
Film Solubility Test	Positive	Positive

\*Values are represented as Mean  $\pm$ SD of triplicate determination, Sample-A: Control (i.e. packaging film without licorice root extract) and Sample-B: Test Sample (i.e. packaging film with licorice root extract)



### **Acknowledgement**

I wish to express my sincere gratitude to my Institute, Manav Rachna International Institute of Research & Studies, and Faridabad, India for giving me an opportunity to transform my idea into a reality.

### **References**

1. Ahvenainen R., Vermeiren L., Heirligs L., Delieghere F., Debevere J. Novel food packaging techniques. Woodhead Publishing Limited: Cambridge England 2003.
2. Brody A.L., Strupinsky E.R., Kline L.R. Active Packaging for Food applications. Technomic Publishing Company, Inc. Pennsylvania, USA, 2001
3. Fenwick GR, Lutomski J and Nieman C, *Liquorice, Glycyrrhiza glabra Linn L. Composition, uses and analysis. J Food Chemistry, 1990.*
4. Karleigh Huff, Active and Intelligent Packaging: Innovations for the Future Department of Food Science and Technology, Virginia Polytechnic Institute and State University (Virginia Tech) Blacksburg, 2015.
5. Labuza TP, Breene WM (1989) Applications of "active packaging" for improvement of shelf life and nutritional quality of fresh and extended shelf life of foods. Journal of Food Processing and Preservation 13.
6. Lopez-Rubio A., Almenar E., Hernandez-Muñoz P., Lagaròn J.M., Català R., Gavara R. (2004) Overview of Active polymer based technologies for food applications. Food Review International. 2004
7. Vermeiren L, Devlieghere F, Debevere J. 2002. Effectiveness of some recent antimicrobial packaging concepts. Food Add Contamin 19(Suppl.):163-71.
8. ASTM. Standard test methods for flame properties of materials. Method D-635. In Annual Book of ASTM Standards. American Society for Testing and Materials. Conshohocken, PA. 1980
9. Nummer L, Trombetta D, Castelli F, Sarpietro MG, Venuti V, Cristani M et al. Mechanisms of antibacterial action of three monoterpenes. Antimicrobial Agents Chemother. 2012;
10. Robertson, G. L. 2006. Active and intelligent packaging. In Food packaging: principles and practice— 2nd ed. CRC Press, Boca Raton, Fl. Chap. 14
11. Xia J. Milliken & Company 2008, US 7,381,762.
12. Yam, K. L., Takhistov, P. T., and Miltz, J. 2005. Intelligent packaging: concepts and applications. Journal of Food Science. 70.
13. Sachdeva A, Vashist D, Rajni, Divya Puri, Antimicrobial activity of active packaging film to prevent bread spoilage International Journal of Food Science and Nutrition 2017.
14. Sungsuwan J, Rattanapanone N, Rachanapun P (2008): Effect of chitosan/methyl cellulose films on microbial and quality characteristics of fresh-cut cantaloupe and pineapple. Postharvest Biol. Technol., 49: 403–410.
15. Muscat D, Adhikari B, Adhikari R, Chaudhary DS (2012): Comparative study of film forming behaviour of low and high amylose starches using glycerol and xylitol as plasticizers, Journal of Food Engineering, Volume 109, Issue 2, pp 189–201.
16. Anita Ivanković BIODEGRADABLE PACKAGING IN THE FOOD INDUSTRY Journal of Food Safety and Food Quality 68, Heft 2 (2017), Seiten 23–52

**Biography of Authors (10pt)**

	<p><b>Divya Yadav</b> <b>Student</b> Divya Yadav has successfully completed her M.Sc Food &amp; Nutrition from Manav Rachna International Institute of Research and Studies, India and B.Sc Biotechnology from Maharshi Dayanand University, India. She has got hands on experience on many sophisticated machines like UV Vis Spectrophotometer, PCR, etc. She also coordinated Indo Japanese Conclave III, held at Manav Rachna International Institute of Research and Studies during 13-14 Feb, 2017.</p>
	<p><b>Ms. Divya Puri</b> <b>Assistant Professor</b> Ms. Divya Puri is a dedicated, resourceful and goal-driven professional educator with a solid commitment to academic and research based growth of every child. She has completed both her B.Sc (hons) Food Technology and M.Sc Food &amp; Nutrition (Specialization: Food Science &amp; Technology) from University of Delhi. She has taught both undergraduate and postgraduate students at University of Delhi and Indira Gandhi National Open University (IGNOU). She has co-supervised B.Tech Food Technology students at University of Delhi on their research projects. She also possesses hands on experience of various techniques in food industries like Coca-cola, Catch Spices and Delhi Milk Scheme. She has presented many papers at international and national conferences. She has also published articles in international/national journals and magazines, and co-authored a book with Food Safety &amp; Standards Authority of India (FSSAI). Her propensity towards research has motivated her to be a part of research projects carried in collaboration between University of Delhi, University of Toronto and Tata Trust respectively. She is an active member of AFST (I) (Association of Food Scientists &amp; Technologists, India).</p>



**Dr. Mahak Sharma**

**Associate Professor**

She has completed her BSc (Home Science) from Institute of Home Economics, Delhi University and MSc (Food and Nutrition) from Banasthali University, Rajasthan. She has completed her PhD as a scholarship holder from Institute of Home Economics; Delhi University in the year 2014 on subject entitled “A study on Metabolic Syndrome and Physical activity in Middle aged population”. She has cleared her UGC – NET, junior research fellowship (JRF) and senior research fellowship (SRF). She has a teaching experience of 4 years in various colleges of high repute like IHM PUSA; Lady Irwin College, Delhi University; Institute of Home Economics, Delhi University. She has expertise in metabolic syndrome (Diabetes, hypertension, heart disease and obesity) and physical activity. She is a certified diabetes educator affiliated by International Diabetes Federation. She has attended numerous conferences, workshops and presented papers. She has presented almost 12 research papers on her research work at national as well as International conferences. She has four original papers in International journal and one in national Journals. She is life member of National Dietetic Association, Nutrition society of India and American society of Nutrition.

## **A Study on Opportunities and Challenges in Developing HRD Climate with special reference to IT Companies in Pune City**

**Smeeta S. Kabadi**

**Dr. Shyamkant Shrigiriwar**

### **Abstract**

The objective of this research paper is to study the new opportunities and challenges in developing HRD climate in IT companies in Pune city. A survey method was used to collect data from 30 respondents using a well-structured questionnaire. The researcher has used descriptive research design and systematic probability sampling method for this study.

### **Introduction**

For an individual to perform productively, the climate established in the organization needs to be favourable for his development. The term 'climate' is used to designate the quality of the internal environment, development of the individual, and commitment towards organizational purpose, and efficiency to work with each other. HRD climate helps employees to acquire traits that would enable them to execute their present or future expected roles and aids in developing their capabilities for organizational development. The HRD Climate of an organization plays a very important role in ensuring the proficiency, enthusiasm and growth of its employees.

Pritchard and Marasick (1973) defined HRD climate as a relatively enduring quality of an organization's internal environment, distinguishing it from other organizations.

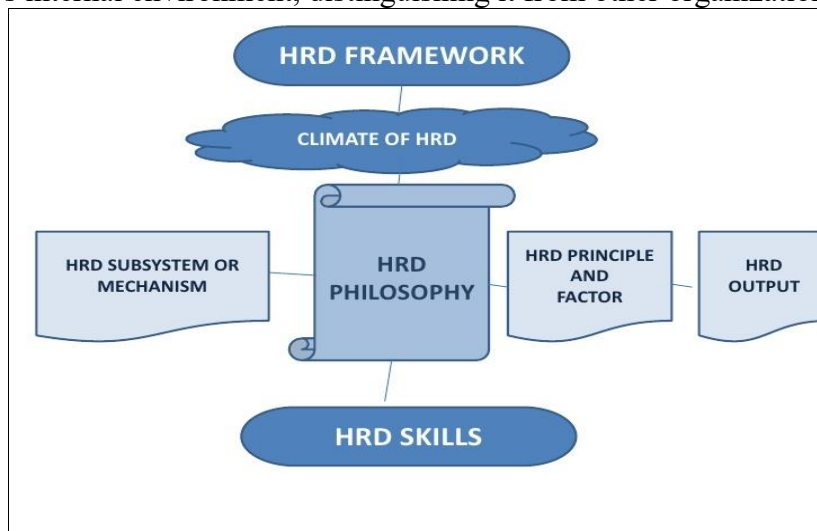

### **IT Sector in Pune**

As the world becomes more digitalised, companies are transforming to use technology more intelligently and strategically. This is leading to creation of new jobs in the IT sector, even as some earlier ones evolve or get obsolete. In the future, the job role of a security analyst will probably remain the same, but new skills or approaches will be required. India's IT industry is focusing greatly on digital opportunities as digitalization is poised to



be a major segment in the next few years. It is also currently the fastest growing segment, growing over 30 per cent annually.

### **Literature Review**

Venkateswaran, and K.P. Sai (1997), in their study, concluded that early identification of human resource potential and development of their skill represents two major tasks of human resource development. This can be achieved only when a conducive HRD climate prevails.

Krishna and Rao (1997) surveyed the organizational and HRD climate, and they observed that environment of openness follows 'good' among middle and senior managers in the company.

Sr. Alphonsa's study (2000) highlights that the supervisors' perception about the HRD climate is satisfactory and there exists a reasonably good value of confrontation.

Rohmetra (1998) conducted a study on the HRD climate and the attitudinal perceptions of employees covering senior, middle and lower managerial levels and the clerical staff. The study shows that there exists an intimate degree of trust and components of attitudinal perception.

Priyadarshini and Venkatapathy's study (2004) highlights that employees have a strong feeling of belongingness, and there is a sense of equality in the common facilities provided to the employees.

### **Research Methodology**

#### **Statement of the Research problem**

It becomes necessary to study opportunities and challenges in developing HRD climate in IT companies as IT sector in the country is growing rapidly from the last decade and Pune city is one of the major hubs of IT companies.

#### **Objectives of the study**

1. To study the HRD mechanism of selected IT companies.
2. To study the various opportunities for developing HRD climate in selected IT companies.
3. To study the challenges in developing HRD climate in selected IT companies.

#### **Scope of the study**

The study deals with opportunities and challenges in developing HRD climate in IT companies in Pune city. The researcher has collected data only from senior IT professionals in IT companies.

#### **Methods of Data collection**

- **Primary Data** - Primary data was collected through a verbal, face to face conversation using the questionnaire prepared.
- **Secondary Data** - All relevant secondary data was collected from various sources like the Internet, Books, Magazines, and Articles etc.

#### **Method of analysis and statistical tools**

A structured questionnaire was used to collect the data, while Ms Excel-2007 was used to analyse the data.

**Research design**

Type of Research Design	Descriptive Research Design
Sampling Technique	Systematic Probability Sampling
Sampling Area	Pune City
Sample Size	30 IT companies (Senior IT Professionals)
Primary Data	Well structured questionnaire
Secondary Data	Research papers, Articles, Books, Journals etc.

**Tabulation & Data Analysis**

Do you find new opportunities in developing/implementing following HRD practices?

Measurement Scale: 1- Never 2- Very Rarely 3- Rarely 4- Most of the Times, 5- Always

Indicators	Mean
Selection Process	3.3
Induction	3.5
Training and Development	4.8
Performance Appraisal	3.7
Compensation process	3.6
Working Environment	4.1
Employee Career Development	4.2
Average Mean	3.9

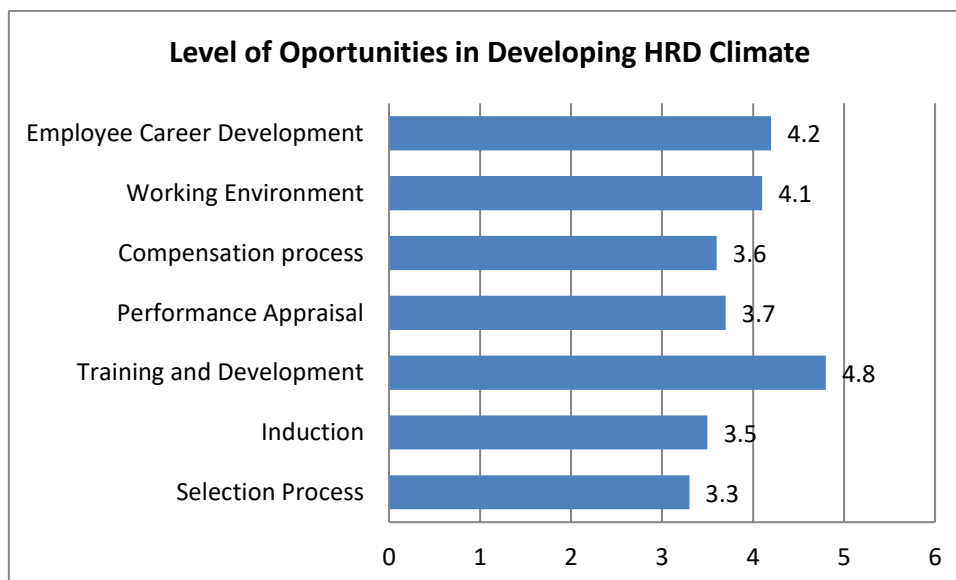

Who helps you to identifying new opportunities in developing HRD climate?

1- Never 2- Very Rarely 3- Rarely 4- Most of the Times, 5- Always

Indicators	Top Management	Middle Management	Lower Management	External Parties
Selection Process	4.2	4.3	2.2	3.6
Induction	4.2	4.4	2.8	1
Training and Development	3.2	4.8	2.8	2.9
Performance Appraisal	2.5	4.6	1	1
Compensation process	4.3	4.3	1	1
Working Environment	2.3	4.7	4.1	1
Employee Career Development	3.8	4.5	2.1	1
Average Mean	3.5	4.5	2.3	1.7

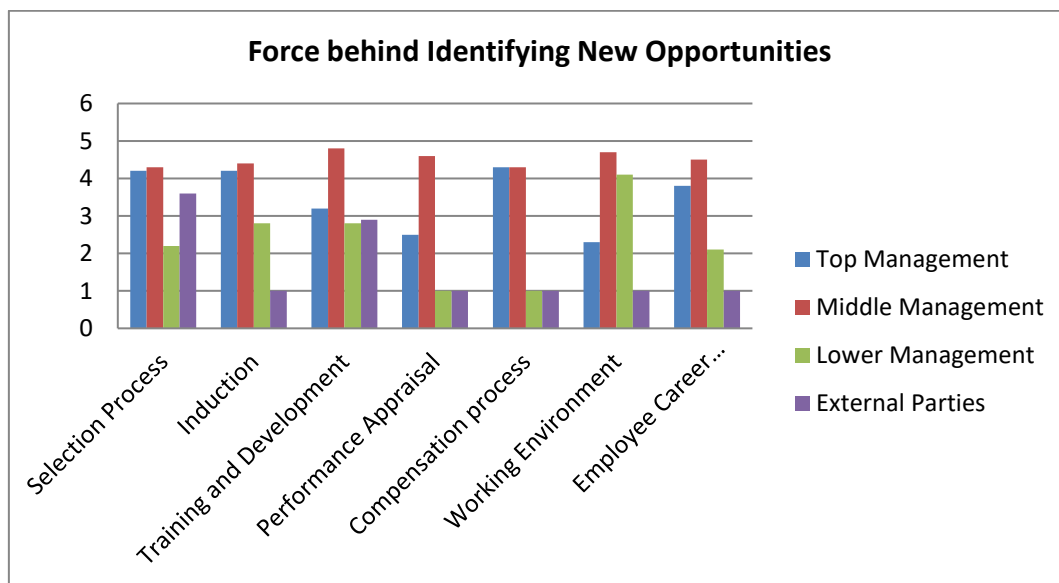

Do you find challenges in developing/implementing following HRD practices?

Measurement Scale: 1- Never 2- Very Rarely 3- Rarely 4- Most of the Times, 5- Always

Indicators	Mean
Selection Process	4.3
Induction	3.8
Training and Development	4.1
Performance Appraisal	3.3
Compensation process	2.5
Working Environment	3.1
Employee Career Development	3.2
Average Mean	3.5

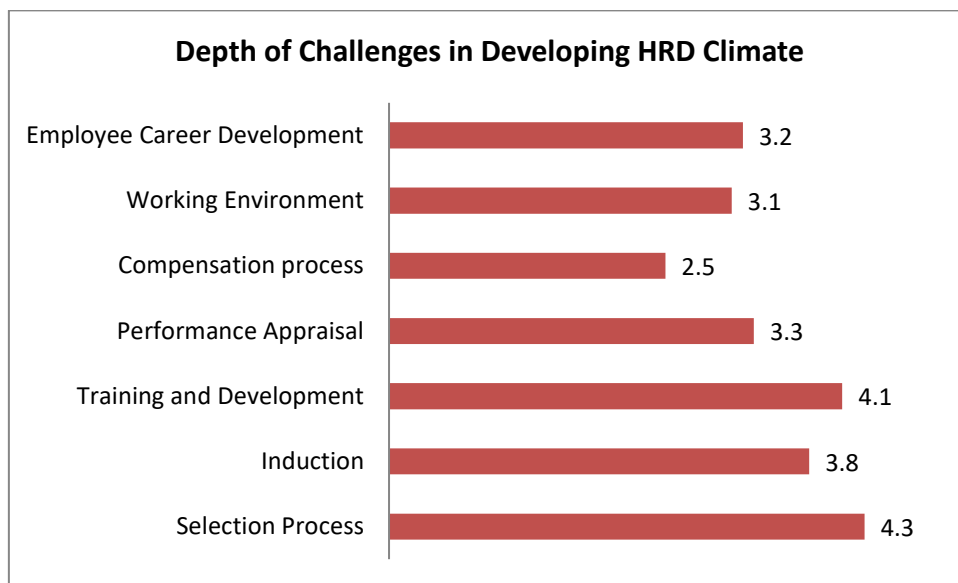

Which level of organization face more challenges in developing HRD climate?

Measurement Scale: 1- Never 2- Very Rarely 3- Rarely 4- Most of the Times, 5- Always

Indicators	Top Management	Middle Management	Lower Management	External Environment
Selection Process	1.3	2.3	1	1
Induction	1.2	2.4	2.6	1
Training and Development	3.2	4.6	2.3	3.9
Performance Appraisal	2.5	4.4	1	1
Compensation process	2.3	3.4	1	1
Working Environment	2.3	3.7	4.1	1
Employee Career Development	3.8	4.1	2.1	1
Average Mean	2.4	3.5	2	1.4

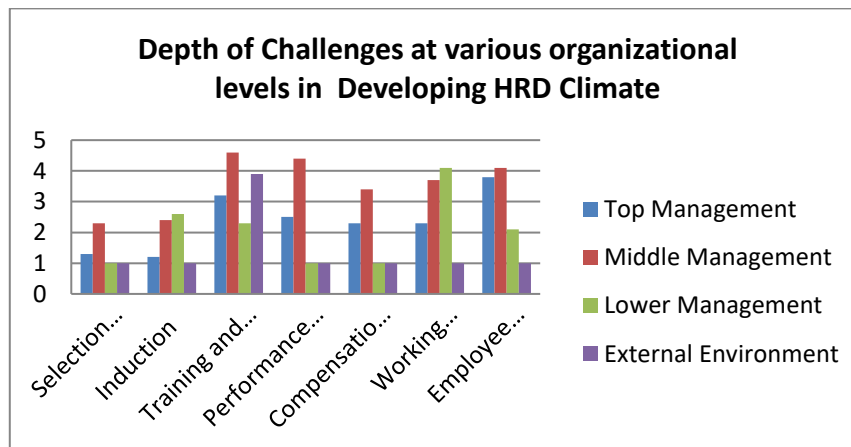

### Findings

- IT companies find opportunities in developing HRD climate most of the time, as the average mean identified is 3.7, but the level of opportunities varies. While providing Training and Development to employees, they find more opportunities and scope as the mean identified is 4.8.
- It has been observed that Middle management plays the most important role in identifying new opportunities for developing HRD climate as the average mean identified is 4.5
- IT companies find challenges in developing HRD climate as the average mean identified is 3.5 but the level of challenges varies. Selection process is the most challenging practice for the IT companies as the mean observed is 4.3.
- It has been observed that in developing HRD climate, the most challenging task arrives at middle management level as the average mean identified is 3.5.

### Bibliography

#### Books

- Patel M.K., "Case studies on HRD Practices", Anmol Publication Pvt. Ltd., New Delhi, 2005.
- Ashwathappa K., Human resource Management and personal management, Tata McGrawhill, 2003
- Pattanayak Biswajit, Human Resource Management, Prentice Hall of India Publication, 2003.
- Dwivedi, R. S., Management of Human Resources, Oxford and IBH, New Delhi, 1985.

#### Research Papers

- Dereli, B. (2006). The Effect of Human Resource Development on the Organizational Commitment. e-Proceedings of the 2nd International Conference on Business, Management and Economics, Altinyunus Resort, Hotel/Convention Center, Cesme, Izmir-Turkey, 15-18 June, 2006.
- O'Driscoll, M.P., & Randall, D.M. (1999). Perceived Organizational Support, Satisfaction with Rewards, and Employee Job Involvement and Organizational Commitment. *Applied Psychology: An International Review*, 48, 197-209.
- Mishra, P. & Bhardwaj, G.,(2002). "Human Resource Development Climate: An Empirical Study among Private Sector Managers", *Indian Journal of Industrial Relations*, 38(1), 66-80.



- Sharma, A. and Purang, P., (2000). "Value Institutionalization and HRD Climate: A Case Study of a Navratna Public Sector Organisation", *Vision-The Journal of Business Perspective*, 4, 11- 17.
- Srimannarayana. M., Oct.(2008). "Human Resource Development Climate in India", *Indian Journal of Industrial Relations*, 44, 248-55. Venkateswaran K. R Sai, (1997).
- "A Note on HRD Climate", *Vikalpa*, 22 (1), 51-53.
- Patterson, M., Warr, P., and West, M., (2004). "Organisational climate and Company Productivity: the Role of Employee Affect and Employee Level", *Journal of Occupational Psychology* 77(2), 193-216. Pillai P.R., (2008).
- "Influence of HRD Climate on the Learning Orientation of Bank Employees", *Indian Journal of Industrial Relations*, 43(3), 406-418.

#### **Websites**

- [www.iosrjournals.org](http://www.iosrjournals.org)
- [www.researchpublish.com](http://www.researchpublish.com)
- [www.wikipedia.com](http://www.wikipedia.com)
- [www.slideshare.com](http://www.slideshare.com)

## **Ambedkar Views on Gender Equality and Human Rights**

**K. SITHARDHANAN\***

**Dr. J. THIRUMAL\*\***

### **Abstract**

Human Rights and Gender Equality in Health Sector Strategies: how to assess policy coherence is designed to support countries as they design and implement national health sector strategies in compliance with obligations and commitments. The tool focuses on practical options and poses critical questions for policymakers to identify gaps and opportunities in the review or reform of health sector strategies as well as other sectoral initiatives. It is expected that using this tool will generate a national multistate holder process and a cross-disciplinary dialogue to address human rights and gender equality in health sector activities the tool is intended for use by various factors involved in health planning and policy making, implementation or monitoring of health sector strategies. These include (but are not limited to) ministries of health and other sectors, national human rights institutions, development partners and civil society organizations. The tool provides support, as opposed to a set of detailed guidelines, to assess health sector strategies. It is not a manual on human rights or gender equality, but it does provide users with references to other publications and materials of a more conceptual and normative nature. The tool aims to operational human rights-based approach and gender mainstreaming through their practical application in policy assessments.

**Keywords:** Gender Equality, Women Empowerment, Human Rights, Women Policy, Social Rights Problems, Caste and Class.

### **Introduction**

The role played by B. R. Ambedkar has left its imprint on the social tapestry of the country after Independence, and shaped the political and civic contour of India today. It would have been a different India without him and, in all probability a much more inequitable and unjust one. He attempted to forge India's moral and social foundations a new and strove for a political order of constitutional democracy that is sensitive to disadvantage, inherited from the past or engendered by prevailing social and political relationship. The basic premise of this tool is that aligning national health sector strategies with obligations and commitments on human rights and gender equality is not only the right thing to do ethically and legally it also leads to better more sustainable and equitable results in the health sector. Every United Nation Member State has undertaken international legal obligations for human rights. More than eighty percent of Member States has ratified four or more of the nine core international human rights treaties. There is near universal agreement for the Convention on the Rights of the Child and the Convention on the elimination of all forms of discrimination against Women both of which recognize health as a human right, the importance of gender equality and several other rights relating to underlying determinants of health.

---

\*Ph.D Research Scholar Department of Philosophy Annamalai University Annamalaiagar-608002

\*\* Dr. J. Thirumal Assistant Professor Department of Philosophy Annamalai University Annamalaiagar-608002

Moreover, the World Health Assembly the governing body of the World Health Organization (WHO) adopts resolutions to guide and direct the Secretariat and the Member States of World Health Organization in the field of health, including gender equality and health-related Human rights. Greater efforts are needed to help Member States full fill goals and obligations such as those outlined in. This includes ensuring that national health sector strategies are consistent with, and further reinforce, human rights standards and principles and gender equality. Historically, international human rights law did not effectively address women's human rights, and women were even excluded from participating in its early development. Initially, the right to health was also narrowly interpreted to exclude women's needs and experiences and failed to address obstacles faced by women in making decisions pertaining to health and obtaining health-related services.

### **Review of literature**

S. Mohammed Azaad (2013), women's economic liberation and for securing women's social rights the all-round development of women was his topmost agenda and he left no stone unturned in achieving this goal. As the Chairman of the Drafting Committee of Constitution, Ambedkar tried an adequate inclusion of women's rights in the political vocabulary and constitution of India. Dr. Ambedkar, a social visionary aptly provided appropriate rights to women in the Constitution through several articles and at a later stage, many more were included. The vision of Ambedkar is yet to become reality and unless minds are united it will be only a distant dream.

Satyajit Das (2015), Ambedkar is one of the greatest personalities of 20th century India. His life was a great saga of suffering, sacrifice and struggle. His birth as an untouchable gave him a bitter taste of caste tyranny, oppression and unbearable agony. He was a fighter for the dignity of man and deprived people. His life was a struggle of a champion of human rights. So obviously he was a great thinker of a woman and their rights. Being a pioneer of social justice, he always worked for the woman emancipation. His principal aim was to build up a society based on social justice. To secure and fulfill his dreams he thought everybody should be equal irrespective of caste, creed, gender and religion. For that reason, he started work for the upliftment of woman and their rights. In this context, the present paper intends and tries to narrate the rights and upliftment of woman in the view of Ambedkar. The endeavor was also given to highlight the relevance of Ambedkar at present-day India.

### **Gender Equality**

The term gender is used to refer to the socially constructed differences between men and women. It prescribes specific roles for them and accordingly defines the status of women and men in the family and in society. Gender prescribes what a man should do and a woman should not and what a woman should do and man should not etc. Despite the fact that sex and gender are used quite often synonymously they are not the same. The term sex is a biological category whereas gender is socially constructed feminine and masculine patterns of behavior for women and men. Gender-based social roles define the nature and type of functions taken up by women and men. In most societies activities of women are limited to looking after home and family.

They are not allowed to participate in activities that go beyond the roles that are confined to family. They are deprived of proper education and job opportunities. Thus making those dependent on men for example father, brother or husband for financial support. This led to

controlling of women by men. This controlling of women by men leads to domination, exploitation and suppression of women by men. Thus giving rise to Gender Inequality. In principle men and women both are same having similar talent, mental faculty, possessing same rights and duties. But in reality, it is just opposite. In most societies women receive unequal treatment, for instance, they are made to stay at home to do household chores, in terms of ownership of property such as land or access to other resources such as food and healthcare women are thoroughly discriminated women are not given political power etc. All such discrimination has given rise to movements focusing on women's liberation. The main focus of the feminist movement is to highlight the social role of women. The ideology of feminism centers on discrimination of women on the basis of her sex without any logical basis. The division of work between male and female is deliberately done by a male-dominated society so as to perpetuate male domination over female.

### **Strategies for Women's Empowerment in India**

The women in India are positioned at a receiving end primarily because they have remained ignorant of their fundamental civil and constitutional rights. Patriarchal system impinges on every sphere of a woman's life. In such a situation often a majority of them are forced to accept the traditional practices that are detrimental for both their and their children's development. Although women have acquired a level of financial and political autonomy and consciousness about their rights, yet they experience helplessness in bringing about basic changes for eliminating gender inequalities from the society.

### **Human Values and Human Rights**

Human values play a significant role in the promotion and realization of human rights in any society. Value help to crystallize any legal action, and play a very important role in the development of society since the concept of right and its exercise and regulation contend round based on a number of values developed from ancient to modern times they have had a great impact in the realization, promotion and protection of human rights. The philosophy of human rights is similar to that of the above values. Therefore values are one of the basic aspects of human rights. These values able to achieve peace, security and harmonious living community without any kind of discrimination that exist between individuals and nation states

The promotion and protection of our central principles to the mandate of the United Nation and all United Nation agencies must work to fundamentally enhance and contribute to their realization by addressing underlying causes of human rights violations including discrimination against women and girls and utilizing processes that are in line with and support these principles. Those United Nation interventions that do not consider these principles risk reinforcing patterns of discrimination and exclusion or leaving them unchanged Human rights are the civil, cultural, economic, political and social rights inherent to all human beings, regardless of one's Nationality, Place of Residence, Sex, Sexual Orientation, National or Racial Origin, Colour, Disability, Religion, Language etc.

All human beings are entitled to these rights without discrimination. They are universal, inalienable, interdependent, indivisible, equal and nondiscriminatory. Human rights are expressed in and guaranteed by normative frameworks and laws that lay down the obligations of States to act in order to respect protect and fulfill the human rights and fundamental freedoms of individuals or groups. We use 'duty bearers' to reflect the obligations of States towards 'rights holders', which represent all individuals in the concerned status.

- **Dignity**

The dignity that regulates the behavior of individual's dignity is a relative term with regulating nature. It prescribes the norms and ethical standards need to be followed and adopted. It peoples across the world follow the ethical norm of dignity without any deviance the realization of the right would be easy.

- **Liberty**

Liberty is another concept which plays a vital role in the promotion of human rights. Liberty is an ancient concept Liberty means human beings are free to regulate their relations are able to govern their relations behave own will. It is a responsibility or duty.

- **Equality**

Equality proposes to bring all the people into one category and apply the principals of law and justice without any distinction. The aims of the contribution of the various countries including India are to treat all the people on an equal footing without any kind of discrimination.

- **Justice**

Justice is an important concept which has attracted a number of fields especially law and philosophy. To achieve perfect justice it lays its emphasis on concepts of equality morality and ethics. Plato said Justice being the highest values to attain it an individual has to provide with all the necessary conditions to realize the right and to discharge his duties towards society.

**Unity in Devise**

Unity in religion in general means, people of different backgrounds bearing on their socio-economically, political cultural perspectives have to live like a simple family. This means the different faiths and characters that people posses have to live in a compatible manner under a single roof governed by a state. This being the main of international law to establish a one world concept, it had given birth to human rights.

**Human Rights and Gender Equality Concepts**

The tool requires a systematic review of the health approach and other relevant documents and processes through the framework of human rights and gender equality. Advance gender equality is a requirement of a, therefore, gender mainstreaming methods must be effectively applied. Combining the two approaches upholds commitments in the System-Wide Policy on gender equality and the empowerment of women.

Methods such as gender analysis and increased involvement of women in decision making are fundamental to realizing human rights and in particular women's human rights. Specifically, gender analysis in health examines how biological and socio-cultural factors interact to influence health behavior, outcomes and services. It also uncovers how gender inequality affects health and Wellbeing. Critical questions on where how and why women or men are affected by a particular condition help to uncover root causes of illness and disease and to shed light on risk factor exposure and vulnerability that women and men experience. Gender analysis further enables identification of women's health needs beyond sexual and reproductive health.

**Human Rights Concepts**

Human rights standards are legal guarantees protecting universal values of human dignity and freedom. They encompass civil, cultural, economic, political and social rights. All human rights are interdependent and interrelated. The standards define the rights and entitlements of all women and men, boys and girls, and the corresponding obligations of



the State as the primary duty bearer. Human rights standards have been negotiated by States and agreed upon in human rights treaties, such as conventions and covenants, which are legally binding on State parties.

### **Gender Concepts**

Gender mainstreaming is a strategy to make women's and men's concerns and experiences an integral part of the design, implementation, monitoring and evaluation of all sectoral policies and program including health. The ultimate goal is to achieve gender equality. Gender is used to describe those characteristics of groups of women and men which are socially constructed, while sex refers to those which are biologically determined.

Gender equality or equality between different groups of women and men refers to the equal enjoyment by groups of females and males of all ages and regardless of sexual orientation or gender identity of rights socially valued goods opportunities resources and rewards. Equality does not mean that women and men are the same but that their enjoyment of rights, opportunities and life chances are not governed or limited by whether they were born female or male.

Gender analysis identifies and addresses inequalities and/or differences experienced by different groups of women and men. With respect to health, it explores the ways that norms, roles and relations may impact differently upon the health of women and men. Critical questions on where, how and why women or men are affected by a particular condition help to uncover root causes of illness and disease and to shed light on risk factor exposure and vulnerability that women and men experience.

### **Conclusion**

The last decade of the twentieth century and early years of the twenty-first century witnessed some significant developments in India indicating an intensification of political struggles involving caste class gender and ethnic identity. The adoption of economic reform in 1991 invited a new stage of economic development in India giving privilege to the capitalist class to lead the process of economic development. Thus, in short, the Millennium Development Goal on gender equality and human rights women's empowerment can be realized in India only when the traditional practices like female infanticide, dowry death, honor killings by khap Panchayat, domestic violence or sexual abuse is eliminated. It is only then that Gender equality and women's empowerment can become reality.

Thus Human rights are the basic human needs and demands they are necessary for the all-round development of a human being. Hence it is expected that civilized state will incorporate these rights in its limitation and try to ensure that its citizens enjoy them. If everyone understands her own proper role and are allowed to function freely, being in mind the objective for which they were established they would be able to fulfill social expectations and hold promises for victims of human rights violations and society. In this context it is necessary to investigate the underlying basic reasons for economic disparity, social inequality unequal distribution of power, status and property in terms of caste, class, gender and ethnicity in order to make a long cherish dream of building an ideal society which is indispensable to emphasize the interconnective nests of various social forms like caste, class, gender and society apart from making them visible as distinct categories to get a holistic image of Indian social reality in future.



## Reference

1. The term “health sector strategy” refers to a national medium-term strategy identifying priority areas and actions to improve health outcomes. The terminology may vary between countries and other common terms are “health sector strategic plan” and “health sector plan”. The health sector strategy may be guided by a long-term “health policy”.
2. United Nations General Assembly, Convention on the Rights of the Child, Resolution 44/25, November 20, 1989.
3. United Nations General Assembly, Convention on the Elimination of All Forms of Discrimination against Women, December 18, 1979. Retrieved from <http://www2.ohchr.org/english/law/cedaw.htm>, accessed 25 August 2010.
4. Satyajit Das (2015), Ambedkar and woman rights: An analysis, International Research Journal of Interdisciplinary & Multidisciplinary Studies (IRJIMS), ISSN: 2394-7969 (Online), ISSN: 2394-7950 (Print) Volume-I, Issue-I, February 2015, Page No. 191-195.
5. S. Mohammed Azaad (2013), Dr. Ambedkar and Gender Equality, Proceedings of the Third International Symposium, SEUSL: 6-7 July 2013, Oluvil, Sri Lanka.
6. The World Health Report 2008 – Primary health care: now more than ever. Geneva, WHO, 2008.
7. Resolution WHA62.14. Reducing health inequities through action on the social determinants of health. In: Sixty second
8. World Health Assembly, Geneva, 18–22 May 2009, Volume 1: Resolutions and decisions, Annexes. Geneva, WHO, 2009 (WHA62/2009/REC/1) 21–25.
9. Commission on Social Determinants of Health. Report by the secretariat to the Sixty second World Health Assembly. Geneva, WHO, 2009 (A62/9).
10. Resolution WHA62.12. Reducing health inequities through action on the social determinants of health. In: Sixty second
11. World Health Assembly, Geneva, 18–22 May 2009, Volume 1: Resolutions and decisions, Annexes. Geneva, WHO, 2009 (WHA62/2009/REC/1) 16–19.
12. Kishwar Madhu, Where daughters are unwanted, Manushi, 86, 1522(1995)
13. Dominic. D, Globalisation Ideology and Human Rights, Hospet Bellary, 2007.
14. Dept of Law, Govt of Karnataka, Policy Paper and Action Plan: A Commitment toward s Reforms, Bangalore, 2005.
15. Pravin Kumar Jha, Indian Politics in Comparative Perspective, Pearson, New Delhi, 2011 pg- 122
16. Manoranjan Mohanty(ed), Caste Class Gender, Sage Publication, New Delhi, 2004

## **Liquidity Risk assessment & management of Banks: Past Evidence from India**

**Gurpreet Kaur\***

**Dr. Renuka Sharma\*\***

### **Abstract**

Efficiency & Effectiveness of the economy is highly dependent on its liquidity position. Banking liquidity determinants are the major drivers of the financial stability in the economy. Inefficiency in identifying such determinants will pose a serious hurdle in maintenance of the financial stability in the economy. Inadequacy in managing liquidity by banks will lead to liquidity risk, which will further lead to banking crisis. "Liquidity Risk is the risk arising due to inability of the banks to meet its short term demand". The present study is an attempt by the researcher to identify the various determinants of liquidity risk. The various regulatory measures taken by RBI to curb liquidity risk are also being assessed in the present study. The literature review reveals that an empirical study needs to be done to analyse all the determinants affecting the banking industry. Moreover, the future research needs to be conducted in exploring & developing management policies for effectively controlling the menace of liquidity risk.

**Keywords:** Liquidity risk, financial stability, assessment etc.

### **Introduction**

As a financial intermediary bank are the key players in maintaining viable financial system of any country. Ever since the financial turmoil of 2008 the Indian Banking Industry has faced significant consequences. It is prone to varied types of systematic and unsystemic risks such as credit risk, liquidity risk, interest rate risk etc. One of the major concerns is the inability of banks to maintain sufficient liquidity. Thus to maintain financial sustainability in the economy, it's very important to focus on the liquidity risk exposed to banks. This paper is an attempt to study the liquidity risk and liquidity risk management practices in context to the Indian Banking Industry. Liquidity risk comes from the failure to identify changes in market conditions that influence the ability to liquidate assets quickly with minimum loss in its value (Tiwari, 2011).

As per Basel committee on banking supervision, 2008 liquidity risk is defined as "Banks ability to fund their assets and meets their obligation, without incurring unacceptable level of losses."

Though in the pre-financial turmoil era, liquidity risk was not considered more hazardous or fragile but ever since the financial turmoil, the attention of most of the researchers, scholars, academicians is shifted to liquidity risk, as it is considered as the main reason of financial turmoil (Teply, 2011) Moreover the global financial turbulence stated that adequate capital and liquidity is a key element in order to assure safety and soundness of funds in the economy

Liquidity risk is referred to as the inability of the banks to convert an asset into cash at a reasonable time at a specific price. Liquidity risk can be measured by two main methods: liquidity gap and liquidity ratios. The liquidity gap is the difference between assets and

---

\*Assistant Professor and Research Scholar, Chitkara Business School

\*\*Professor, Chitkara Business School

liabilities at both present and future dates. At any date, a positive gap between assets and liabilities is equivalent to a deficit (Bessis, 2009).

The present study consists of the following sections. Section 2 deals with the objectives of the study. Section 3 describes research methodology to be adopted in the study. Section 4 deals with analysis & interpretation of previous research. Section 5 deals with the conclusion & scope of further research. Section 6 deals with references.

### **Objectives of the Study**

The main purpose of the present paper is to study the current status of liquidity risk and liquidity risk management practices in context to the Indian Banking Industry by reviewing the past research publication so as to provide the present and future researchers a prospects for further study. The study is well organised as it provides the various determinants of liquidity risk and the liquidity risk management approaches used by the banks.

The secondary objective of the paper is to segregate the study of liquidity risk into varied levels such as identification of determinants of liquidity risk, RBI guidelines to curb liquidity risk, liquidity risk management Models used. Furthermore the paper gives necessary suggestions to the future researchers on the prospects of the liquidity risk in context to Indian Banking Industry.

### **Research Methodology**

#### **Data**

The present paper is sum up of more than 50 research papers from period of 2000 to 2017 by varied researchers who have investigated upon the different determinants of liquidity risk and the liquidity risk management practices being carried out in different countries.

#### **Methodology**

The present paper is attempted to study liquidity risk & distress of the Indian Commercial banks. Relevant papers related to liquidity risk & liquidity risk management are considered for the present study. The papers are taken from referred academic research journals for the present study. The relevant studies are segregated into following categories: year wise research segregation, collection of research papers from varied database and segregation of review of literature. Table 1 shows the year wise research.

#### **1. Year wise Research Segregation**

The year wise research conducted is showed in the following table.

**Table-1 Shows that the maximum studies were done in the year 2015.**

S.NO.	YEAR	NO. OF STUDIES
1	2017	4
2	2016	3
3	<b>2015</b>	<b>10</b>
4	2014	5
5	2013	5
6	2012	3
7	2011	5
8	2010	1
9	2009	4
10	2008	4
11	2007	3
12	2004	1
13	2002	2
<b>TOTAL NO. OF PAPERS</b>		<b>50</b>

#### **2. Collection of database**

The collection of research papers is done from following journals/ websites as is shown in the following table.

**Table-2 Shows that maximum number of papers on the said topic were published in “Journal of banking & finance”.**

<b>Journals Name</b>	<b>No. of Papers</b>
<i>Journal of Islamic Accounting and Business Research</i>	1
<i>Quantitative Finance</i>	1
International review of management and business research	1
<i>Journal of Applied finance and banking</i>	1
International Journal of Business and Management	1
<i>Journal of Financial Regulation and Compliance</i>	1
Qualitative research in financial markets	1
<i>Journal of Financial Services Research</i>	1
<i>International Journal of Islamic and Middle Eastern Finance and Management,</i>	1
<i>Journal of Banking &amp; Finance</i>	5
<i>The British Accounting Review</i>	1
<i>Research in International Business and Finance</i>	1
<i>Journal of Financial Economics</i>	1
<i>International Journal of Advanced Research</i>	1
<i>Journal of Comparative Economics</i>	1
<i>Academy of Accounting and Financial Studies Journal</i>	1
Netherlands Central Bank, Research Department	1
<i>Business: Theory &amp; Practice</i>	1
Emeraldinsights.com	1
International Review of Economics & Finance	1
<i>Journal of Financial Economics</i>	1
<i>The risks of financial institutions</i> (pp. 105-132). University of Chicago Press.	1
<i>Emerging Markets Review</i>	1
<i>Global journal of management and business research</i>	1
<i>International Journal of Islamic and Middle Eastern Finance and Management</i>	1
<i>Journal of Banking and Financial Economics</i>	2
<i>Review of Finance</i>	1
Journal of Scientific and Industrial Research	1
Journal of Economics and Financial Issues	1
<i>Research Journal of Finance and Accounting</i>	2
papers.ssrn.com	3
<i>Journal of Financial Intermediation</i>	1
<i>Procedia Economics and Finance</i>	1
<i>Business, Management and Economics Research</i>	1
<i>17th Conference on the theories and practices of securities and financial markets, Hsi-Tze Bay, Kaohsiung, Taiwan.</i>	1
<i>Future Business Journal</i>	1
<i>IUP Journal of Bank Management</i>	1
<i>Proc. of 2010 International Conference on Business and Economic Sciences, Dubai: World Academy of Science, Engineering and Technology</i>	1
China Finance Review International	1
<i>IAOS: Measuring productivity</i>	1
<i>Journal of Financial Stability</i>	2
<i>e-Finance, Proceedings of 13th International Conference on Finance and Banking</i>	2
<b>TOTAL</b>	<b>52</b>

### **Interpretation of Previous Research**

This section deals in the segregation of review of literature into following phases:-

1. Identifying the determinants of liquidity risk & implications of liquidity risk management by the banks.
2. Guidelines as given by RBI to commercial banks for liquidity risk management based on the directions of BCBS.
3. Different Models suggested for Liquidity Risk Management.

### **The Review of literature relating to identification of determinants of liquidity risk are discussed as follows**

Singh & Sharma (2016) applied Pooled OLS Regression Method on the Panel Data of 59 banks of BRICS Countries over a period of 12 years to study the impact of bank specific factors on the banks liquidity. The study depicted positive relationship of deposits, profitability, capital adequacy and bank's liquidity and a negative relationship between bank size and bank's liquidity. Umar & Sun (2016) studied the bank specific determinants of liquidity risk of the commercial banks CEE Countries over a period of 13 years by applying Multiple Linear Regression, Econometric Model. Findings revealed a positive relationship of liquidity creation & return on equity, bank size & a negative relation of liquidity creation & interest rate. Valla et.al measured the liquidity of banks for a time duration of 13 years taking into account bank specific factors. The result of the study suggested that there should be cross check on the liquidity ratios and liquidity flows in order to have effectiveness in designing a robust approach towards the liquidity. Sheefeni (2016) studied the bank specific factors affecting the commercial bank's liquidity in Namibia using ordinary least square (OLS) technique over a period of 14 years. The result pinpoints a negative link between return on equity & commercial bank's liquidity and a significant positive relationship between capital adequacy, non-performing assets & commercial bank's liquidity. Khoury (2015) studied the bank specific factors affecting the liquidity of 23 banks of Lebane. The research revealed that higher liquidity is directly and positively linked to the bank size and is directly and negatively related to lower growth rate. Renata (2015) identified the determinants of liquidity risk in the 42 developed countries over a period of 12 years using the Panel Data Regression Analysis and the result of the study suggested that the global determinants of liquidity will be helpful in managing the liquidity risk. Moussa (2015) studied the determinants of banks liquidity and concluded that the management efficiency and capitalization have a positive impact on the bank's liquidity whereas bank size, have a negative impact on the liquidity. Sheikh (2015) applied panel data to study the determinants of liquidity risk in Islamic Banks of Pakistan. He concluded that deposits to total capital ratio increases the liquidity risks in the banks. Further it was concluded that increase in capital to financing ratio decreases the liquidity risk and increase in spread increases liquidity risk. Roman & Sargu (2015) used OLS Regression Analysis on sample of CEE Countries over a period of 8 years. The research took into consideration both the internal & external factors influencing liquidity risk & concluded that there exists negative impact of depreciation on loans on the liquidity. Besides this total capital ratio, return of average equity, ratio of impaired loans to total loans are the major factors that effects the overall liquidity of the banks. Almazari (2014) conducted study on the Saudi and Jordanian Banks to identify the internal factors that effected the profitability of such banks. The study concluded that there is a positive correlation between the profitability (ROA) and liquidity. Further, there is negative



correlation between other determinants and liquidity. Ferrouhi (2014) identified the determinants of bank performance and further studied the relationship between the bank liquidity and bank performance of Morocco banks for duration 12 years. The author applied panel data regression model took into consideration bank specific factors of bank's performance. The study revealed bank performance is positively related to bank's size and is negatively dependent on external funding to total liabilities & own bank's capital of the total assets. Vodova (2013), using Panel Data Regression Approach attempted to determine the factors of liquidity in commercial banks operating in Hungary. The research revealed a positive relationship between capital adequacy of banks, interest rate on loans, banks profitability and banks liquidity. Further it revealed that there exist insignificant relationship between bank size, interest margin and banks liquidity. Khan & Syed (2013) investigated upon the factors of liquidity risk in commercial banks of Pakistan and studied the effect of these determinants upon the profitability of the of the banks using multiple regression model. The result of the study depicts positive relationship between deposits and banks profitability. Further a negative relationship was concluded between NPL's and bank's profitability. Arif & Nauman (2012) examined the liquidity risk in 22 Pakistani banks and assessed its impact on the bank's profitability, by applying series of Multiple Regressions on a Panel Data over a period of 6 years. The conclusion of the paper suggested that maintaining sufficient cash reserve, increasing deposits, decreasing liquidity gaps & non- performing loans will lead to mitigation of liquidity risk. Vodova (2011) undertook a study for identifying the factors affecting the liquidity in the commercial banks of Slovakia. Applying panel data regression analysis on the data of 10 years, the study revealed higher profitability, higher capital adequacy, greater bank size will lead to decrease in banks liquid assets.

The above studies revealed that most of the studies pertaining to liquidity risk relates to developed countries and there is scarcity of studies in context to the Indian banking industry. This further arose the need to conduct a study for identifying factors leading to liquidity risk so as to minimise the future risk.

**The Review of literature relating to liquidity risk management practices is discussed as follows**

Khiari et.al (2017) undertook a study in France to identify the factors that are significantly influencing liquidity of the interbank deposit markets. The study revealed that deposits have a significant in the transmission of liquidity shocks in the banking industry. Chiarmonete et.al (2017) studied the influence of capital and liquidity ratios on the financial distress / probability of bank's failure by applying EBS stress test, Robustness Test. The study concluded that increased liquidity holdings, will help in decreasing the likelihood of failure & distress. Further it's concluded that capital ratios are significant only for large banks. Bonfirm & Kim (2017) emphasised on the period prior to the global financial crises & suggested the need to regulate the liquidity risk by using the macroprudential approach. Megeid (2016) made an attempt to study the comparison of liquidity risk management practices followed by the Islamic & Convectional Banking industry of Egypt. The study revealed that in the conventional the factors which positively impact the liquidity management are the asset quality management & funding. Whereas in the Islamic banks, asset quality management have negative effects on the liquidity. Ratnovski (2013) investigated upon the role of liquidity buffers and banks transparency in liquidity risk management practices in banking industry. The study highlighted various liquidity



regulations to improve the banks transparency. Similar study was conducted by Alshatti (2015) in Jordanian commercial banks. The result showed that the profitability has direct relation with the quick ratio and investment ratio and the profitability decreases with an increase in capital ratio & liquid asset ratio. The study recommended the use of uniform guidelines for the liquidity management. Agbada and Osuji (2013) conducted a research to study the impact of effective liquidity management on the performance of banks operating in Nigeria. The research indicated a direct relation between effective liquidity management and the bank's performance. Moreover it is concluded that efficient liquidity management in the banking industry improves the bank's performance. Asongu (2013) studied the steps taken by banks post crisis to manage liquidity risk by investigating the sample of 20 banks. Iqbal (2012) applied regression to analyse & compare the bank specific factors causing liquidity risks in Islamic & conventional banks of Pakistan. The study concluded that there is positive relationship of CAR, ROA, ROE, & bank size on the liquidity risk of the banks, further there exists negative relationship of NPL & liquidity risks. Further it is depicted that liquidity position of Islamic banks is better in comparison to the conventional banks. Cornett et.al (2011) studied the liquidity risk management practices during the financial crises and revealed that banks had more of illiquid assets in the balance sheet which lead to decline in even the credit supply. Teply (2011) studied sample of 3 years to study the obstacles in the development of liquidity risk management and concluded that main issue behind it is lack of liquidity measurement, liquidity system, control & governance. Adebayo et al. (2011) investigated upon the liquidity management practices in Nigeria and its impact upon the commercial banks' profitability. The study revealed that liquidity and profitability are significantly related to each other and vive-versa. Nikolaou (2009) studied the notion of liquidity & liquidity risk within the financial system together with the role of central bank in managing the liquidity risk. The study concluded timely supervision and regulation is required to confront the causes of liquidity risk. Ismal (2010) used Liquidity Risk Management Index to assess the management of liquidity in the Islamic Banking system considering the bank specific factors and concluded that the liquidity was not optimally regulated in Islamic banks. Fiedler et.al. (2002), Strahan (2007) conducted research to get a deep insight into the liquidity risk management practices being followed and the need of such practices. The research of Franck & Krausz (2007) focused on the sample of 61 banks over a period of 7 years to study the varied risks faced by the banks. Stenbacka et.al (2004) focused on the liquidity risk in banking sector due to the depositors and to develop a model to identify the probability of liquidity crisis. The study revealed that cost of reserves maintenance and bank's penalty rate are important factors helpful in predicting the probability of a liquidity crisis in the economy. Strahan (2009) studied the structure of loan syndicate in commercial banks and concluded that commercial banks are in the capacity to bear with the systemic liquidity risk exposures as they have more access to funds when the market liquidity declines.

The review of above papers concludes that the future studies can emphasise on the liquidity risk management as liquidity position affects the continuity of commercial banks and a weak liquidity position might lead to the liquidation of commercial banks.

**The literature review relating to various models for measuring liquidity risk are discussed as follows**

Boumediene (2015) used government budget deficit as a liquidity risk mitigating tool, and applied Generalized autoregressive conditional heteroskedasticity model to manage

liquidity risk. Bonner (2014) applied regression robustness test to analyse the bank specific determinants in designing the bank's liquidity risk management & to analyse the role of liquidity regulation & to identify the determinants of banks liquid assets holdings. The study suggested disclosures and liquidity requirements provide strong incentive to the regulators to jointly harmonize disclosures. Xia (2014) used structural credit risk model and sensitivity analysis to study the contribution of liquidity risk in the total default risk of the banks. The study revealed that the liquidity risk is expanding in volatility and in terms of ratio of short term funding over total debt. The study also suggested various measures to overcome the liquidity risks. Delis (2014) applied Panel Data Approach and variability of the profit function model to estimate the bank risk considering the bank specific factors. The study that risk varies with the bank size and further concluded profit function as a good indicator of financial distress in Banks. Another study undertaken by Claudia (2011) was on the development of a model for minimising the liquidity risk in the economy. Dinger (2009) undertook a research to study the empirical evidence of transnational banks' liquidity behaviour and its impact on the aggregate bank's liquidity in CEE Countries. The study concludes that transnational banks liquidity is different in comparison to other banks. In time of liquidity crises the transnational banks tends to hold less liquid reserves in comparison to other banks. Acerbi & Scandolo (2008) investigated into liquidity risk from a point view in axiomatic context of coherent measures of risk. The study proposed formulation of liquidity risk model which is compatible with coherent risk measures. Den (2008) applied Monte Carlo Approach on bank specific factors of liquidity and a Liquidity Stress- testing Model to determine the probability of risk in the banks. The study revealed that Liquidity Stress Tester is an important tool to study the risk factor in the banks. The review of above papers gives an insight that besides the above models for risk management, the future research needs to be conducted in exploring alternative techniques for developing liquidity risk management scores.

### **Conclusion & Scope of Further Research**

A strong liquidity position is of great importance in the economy. The review of literature reveals that in order to improve the financial health of the economy, Indian banks needs to make necessary efforts to maintain liquidity so as to have steady return on assets. The present study is an attempt to explore different determinants of liquidity and to study the different liquidity risk management guidelines as laid down by RBI from time to time. The researchers have concluded that increased liquidity of bank's assets reduces the main cause of fragility (Wagner, 2007). Other researches stressed on exploring the bank specific factors. Some such instances are study of (Khoury, 2015) concludes that bank specific determinants must be monitored; since more liquid assets are required as the bank size increases. Bonner highlighted the role bank specific variables in liquidity risk management. Bonfirm & Kim (2017) concluded that there is scarce empirical evidence on the determinants of liquidity risk and stressed upon the need to explore the determinants of liquidity risk. Further researches have concluded that from past experiences that proper liquidity management on both financial market and the banking sector is of greater importance. Thus, it is evident that liquidity and liquidity risk is a very up-to-date topic (Vodova, 2013). Banks must keep adequate amounts of capital resources and liquidity resources to ensure that they can meet their liabilities when they are due (Tiwari, 2009). Therefore the literature study declares that to ensure financial soundness in the economy there is a need

to monitor the liquidity of the banks. Moreover the future research needs to be conducted in exploring different determinants of liquidity risk and in developing different models for minimising liquidity risk.

Present study is a compiled review comprising of references for which papers cited may be referred.

### **References**

- Abdel Megeid, N. S., & Abdel Megeid, N. S. (2017). Liquidity risk management: conventional versus Islamic banking system in Egypt. *Journal of Islamic Accounting and Business Research*, 8(1), 100-128.
- Acerbi, C., & Scandolo, G. (2008). Liquidity risk theory and coherent measures of risk. *Quantitative Finance*, 8(7), 681-692.
- Agbada, A. O., & Osuji, C. C. (2013). The efficacy of liquidity management and banking performance in Nigeria. *International review of management and business research*, 2(1), 223-233.
- Almazari, A. A. (2014). Impact of internal factors on bank profitability: Comparative study between Saudi Arabia and Jordan. *Journal of Applied finance and banking*, 4(1), 125.
- Alshatti, A. S. (2015). The Effect of the Liquidity Management on Profitability in the Jordanian Commercial Banks. *International Journal of Business and Management*, 10(1), 62.
- Arif, A., & Nauman Anees, A. (2012). Liquidity risk and performance of banking system. *Journal of Financial Regulation and Compliance*, 20(2), 182-195.
- Asongu, S. A. (2013). Post-crisis bank liquidity risk management disclosure. *Qualitative research in financial markets*, 5(1), 65-84.
- Bessis, J. (2011). *Risk management in banking*. John Wiley & Sons.
- Bonfim, D. (2017). Liquidity risk and collective moral hazard!
- Bonner, C., Van Lelyveld, I., & Zymek, R. (2015). Banks' liquidity buffers and the role of liquidity regulation. *Journal of Financial Services Research*, 48(3), 215-234.
- Boumediene, A. (2015). Financing government budget deficit as a liquidity risk mitigation tool for Islamic Banks: A dynamic approach. *International Journal of Islamic and Middle Eastern Finance and Management*, 8(3), 329-348.
- Buch, C. M., & Neugebauer, K. (2011). Bank-specific shocks and the real economy. *Journal of Banking & Finance*, 35(8), 2179-2187.
- Chiaromonte, L., & Casu, B. (2017). Capital and liquidity ratios and financial distress. Evidence from the European banking industry. *The British Accounting Review*, 49(2), 138-161.
- Chouchène, M., Ftiti, Z., & Khiari, W. (2017). Bank-to-bank lending channel and the transmission of bank liquidity shocks: Evidence from France. *Research in International Business and Finance*, 39, 940-950.
- Cornett, M. M., McNutt, J. J., Strahan, P. E., & Tehranian, H. (2011). Liquidity risk management and credit supply in the financial crisis. *Journal of Financial Economics*, 101(2), 297-312.
- Datey, R., & Tiwari, K. (2014). Basel III norms and Indian banks—a new definition of risk management. *International Journal of Advanced Research*, 2(7), 894-905.
- Delis, M. D., Hasan, I., & Tsionas, E. G. (2014). The risk of financial intermediaries. *Journal of Banking & Finance*, 44, 1-12.

- Dinger, V. (2009). Do foreign-owned banks affect banking system liquidity risk?. *Journal of Comparative Economics*, 37(4), 647-657.
- Drehmann, M., & Nikolaou, K. (2013). Funding liquidity risk: definition and measurement. *Journal of Banking & Finance*, 37(7), 2173-2182.
- El Khoury, R. (2015). Liquidity in Lebanese Commercial Banks and Its Determinants. *Academy of Accounting and Financial Studies Journal*, 19(3), 57.
- End, J. W. (2008). *Liquidity Stress-Tester: A macro model for stress-testing banks' liquidity risk*. Netherlands Central Bank, Research Department.
- Ferrouhi, E. M. (2014). Bank liquidity and financial performance: evidence from Moroccan banking industry. *Business: Theory & Practice*, 15(4).
- Fiedler, R., Brown, K., & Moloney, J. (2002). Liquidity risk: what lessons can be learnt from the crisis in Japan's banking system?. *Balance Sheet*, 10(1), 38-42.
- Franck, R., & Krausz, M. (2007). Liquidity risk and bank portfolio allocation. *International Review of Economics & Finance*, 16(1), 60-77.
- Gatev, E., & Strahan, P. E. (2009). Liquidity risk and syndicate structure. *Journal of Financial Economics*, 93(3), 490-504.
- Gatev, E., Schuermann, T., & Strahan, P. (2007). How do banks manage liquidity risk? Evidence from the equity and deposit markets in the Fall of 1998. In *The risks of financial institutions* (pp. 105-132). University of Chicago Press.
- Hou, X., Wang, Q., & Zhang, Q. (2014). Market structure, risk taking, and the efficiency of Chinese commercial banks. *Emerging Markets Review*, 20, 75-88.
- Iqbal, A. (2012). Liquidity Risk Management: A comparative study between Conventional and Islamic banks of Pakistan. *Global journal of management and business research*, 12(5).
- Ismal, R. (2010). Assessment of liquidity management in Islamic banking industry. *International Journal of Islamic and Middle Eastern Finance and Management*, 3(2), 147-167.
- Karkowska, R. (2015). Global Liquidity Determinants Across Emerging and Advanced Countries. *Journal of Banking and Financial Economics*, (1 (3)), 152-170.
- Khan, M. K. R., & Syed, N. A. (2013). Liquidity Risk and Performance of the Banking System. *Journal of Scientific and Industrial Research*, 11(2), 55-70.
- Liang, G., Lütkebohmert, E., & Xiao, Y. (2013). A multiperiod bank run model for liquidity risk. *Review of Finance*, 18(2), 803-842.
- Moussa, M. A. B. (2015). The determinants of bank liquidity: case of Tunisia. *International Journal of Economics and Financial Issues*, 5(1), 249.
- Nikolaou, K. (2009). Liquidity (risk) concepts: definitions and interactions.
- Nworji, I. D., Adebayo, O., & David, A. O. (2011). Corporate governance and bank failure in Nigeria: Issues, challenges and opportunities. *Research Journal of Finance and Accounting*, 2(2), 1-19.
- Ratnovski, L. (2013). Liquidity and transparency in bank risk management. *Journal of Financial Intermediation*, 22(3), 422-439.
- Renata, K. (2015). Global Liquidity Determinants Across Emerging and Advanced Countries. *Journal of Banking and Financial Economics*, (1 (3)), 152-170.
- Ringbom, S., Shy, O., & Stenbacka, R. (2004). Optimal liquidity management and bail-out policy in the banking industry. *Journal of Banking & Finance*, 28(6), 1319-1335.



Roman, A., & Sargu, A. C. (2015). The impact of bank-specific factors on the commercial banks liquidity: empirical evidence from CEE countries. *Procedia Economics and Finance*, 20, 571-579.

Shaikh, S. A. (2015). Panel Data Estimation of Liquidity Risk Determinants in Islamic Banks: A Case Study of Pakistan.

Sheefeni, J. P. (2016). The Impact of Bank-Specific Determinants on Commercial Banks's Liquidity in Namibia. *Business, Management and Economics Research*, 2(8), 155-162.

Shen, C. H., Chen, Y. K., Kao, L. F., & Yeh, C. Y. (2009, June). Bank liquidity risk and performance. In *17th Conference on the theories and practices of securities and financial markets, Hsi-Tze Bay, Kaohsiung, Taiwan*.

Singh, A., & Sharma, A. K. (2016). An empirical analysis of macroeconomic and bank-specific factors affecting liquidity of Indian banks. *Future Business Journal*, 2(1), 40-53.

Subramoniam, K. (2015). Basel III Framework on Liquidity Standards: The Challenges Before the Indian Banks on Liquidity Risk Management. *IUP Journal of Bank Management*, 14(3), 40.

Teply, P. (2011, January). The future regulatory challenges of liquidity risk management. In *Proc. of 2010 International Conference on Business and Economic Sciences, Dubai: World Academy of Science, Engineering and Technology* (Vol. 73, pp. 657-661).

Umar, M., Umar, M., Sun, G., & Sun, G. (2016). Determinants of different types of bank liquidity: evidence from BRICS countries. *China Finance Review International*, 6(4), 380-403.

Valla, N., Saes-Escorbiac, B., & Tiesset, M. (2008). Bank liquidity and financial stability. *IPM24 with IAOS: Measuring productivity*, 40.

van den End, J. W. (2008). *Liquidity Stress-Tester: A macro model for stress-testing banks' liquidity risk*. De Nederlandsche Bank.

van den End, J. W., & Tabbae, M. (2012). When liquidity risk becomes a systemic issue: Empirical evidence of bank behaviour. *Journal of Financial Stability*, 8(2), 107-120.

Vodov, P. (2013). Determinants of commercial bank liquidity in Hungary. *e-Finanse*, 9(3), 64.

Vodová, P. (2011, November). Determinants of Commercial Bank's Liquidity in Slovakia. In *Lessons Learned from the Financial Crisis. Proceedings of 13th International Conference on Finance and Banking* (pp. 740-747).

Wagner, W. (2007). The liquidity of bank assets and banking stability. *Journal of Banking & Finance*, 31(1), 121-139.

## **Review Article: Application of Chemicals in Agriculture**

**Sunil Kumar V\***

**Padmaja D\*\***

**Sudhakar K\*\*\***

### **Abstract**

Different synthetic organic and inorganic chemicals as fertilizers to increase the production of crops to provide food to all people. It also deals with the application of various types of synthetic organic compounds as pesticides or biocides to save the crops from insects and pests as well as their toxic effect on the living being. The focus of this review is on synthetic organic compounds-especially those that are toxic or can generate other adverse effects in the environment. The nature and environmental properties of them have been discussed through searching their chemistry, stability and way of entrance in the environment. Also, the mechanism of degradation and the chemistry of intermediate during decomposition of some pesticides in the environment have been represented in a very simple way. Key-Words: Environment, Synthetic, Agriculture, Soil, Toxicity, Pesticide, Fertilizer, Manure, Zooplankton and Mineralisation.

**Key words:** Agriculture, chemicals and crops

### **Introduction**

The basic need of human being is food. It is the agriculture only which fulfils this need for the entire population of the world. The practice of producing crops and livestock from the natural resources of the earth is called Agriculture. Modern agriculture includes agronomy, horticulture, animal husbandry, dairying, soil chemistry, etc.

Chemistry deals with compounds, both organic, inorganic, and agriculture deals with the production of organic products using both organic and inorganic inputs Thus Chemistry forms an integral part of agriculture from molecular to organ level. It plays a role from the basics of photosynthesis to the utilization of agricultural produce. The advancements in this practice is only because of active research carried out in chemistry and then its applications to cause the land to produce more abundantly and at the same time to protect it from deterioration and misuse. Role of Chemistry in agriculture can be classified as follows:

Agricultural chemicals have an important role in land management and the production of food and fibre products, protecting plants from damage caused by insect pests, weeds or disease. In most cases, agricultural chemicals are referred to as 'pesticides' and include herbicides, fungicides, insecticides and pest animal baits.

Modern agriculture depends quite heavily on the advances that have been made in science and chemistry in particular, to maximize the yield of crops and animal products. Fertilizers, pesticides, and antibiotics play ever increasing roles in this field (Chitra Joshi 2011).

---

\* Chemistry lecturer, Sriganayathri Junior College, Nizampet, Hyderabad

\*\*Scientist, Regional Agricultural Research Station, Polasa, Jagtial.

\*\*\* Head of the department, AI, Green pharma solutions, Miyapur, Hyderabad.



Fertilizer (or fertiliser) is any organic or inorganic material of natural or synthetic origin (other than liming materials) that is added to a soil to supply one or more plant nutrients essential to the growth of plants. A recent assessment found that about 40 to 60% of crop yields are attributable to commercial fertilizer use.

Fertilizers are perhaps the most widely used form of chemical in agriculture. Fertilizers are added to the soil in which crops are growing to provide nutrients required by the plants. Fertilizers can be divided into two categories: organic and inorganic. Organic fertilizers are derived from living systems and include animal manure, guano (bird or bat excrement), fish and bone meal, and compost. These organic fertilizers are decomposed by microorganisms in the soil to release their nutrients. These nutrients are then taken up by the plants. Inorganic or chemical fertilizers are less chemically complex and usually more highly concentrated. They can be formulated to provide the correct balance of nutrients for the specific crop that is being grown. Both organic and inorganic fertilizers supply the nutrients required for maximum growth of the crop. Inorganic fertilizers contain higher concentrations of chemicals that may be in short supply in the soil. The major or macro-nutrients in inorganic fertilizers are nitrogen, phosphorous, and potassium. These fertilizers also may provide other nutrients in much smaller quantities (micro-nutrients). With the expansion of cities due to increases in population, there has been a loss of agricultural land. Appropriate use of fertilizers to increase crop yield has in part counterbalanced this loss of land (Chitra Joshi **2011**).

Mined inorganic fertilizers have been used for many centuries, whereas chemically synthesized inorganic fertilizers were only widely developed during the industrial revolution. Increased understanding and use of fertilizers were important parts of the pre-industrial British Agricultural Revolution and the industrial Green Revolution of the 20th century (Chitra Joshi **2011**). Inorganic fertilizer use has also significantly supported global population growth — it has been estimated that almost half the people on the Earth are currently fed as a result of synthetic nitrogen fertilizer use. According to its chemical structure, pesticides are classified into different families, ranging from organochlorine and organophosphorus compounds to inorganic compounds. In this paper, here we presenting some of the pesticides structures depicted as below.

**Figure 1: Pesticides**

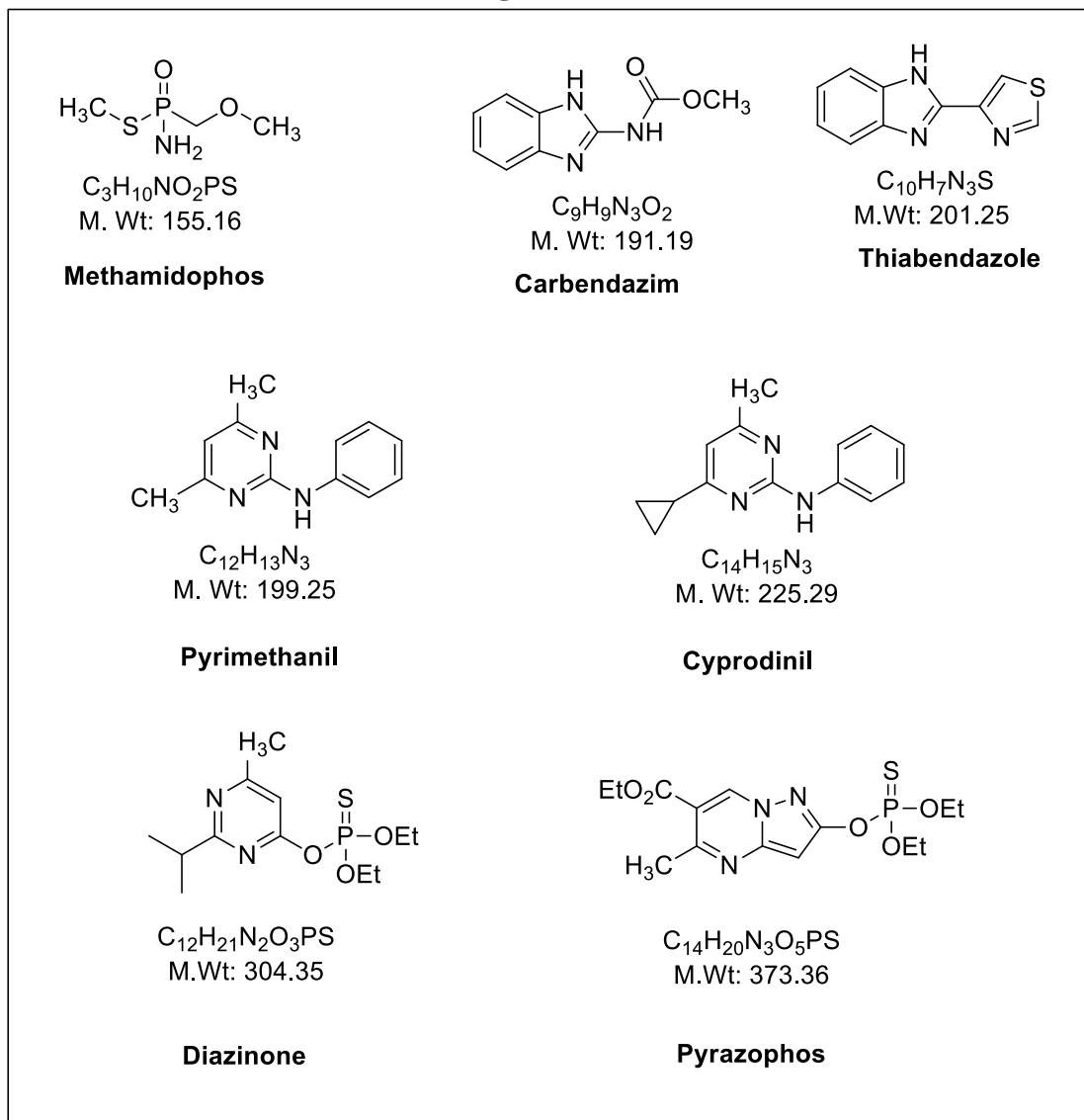

Fertilizers can be divided into two categories: organic and inorganic. Organic fertilizers are derived from living systems and include animal manure, fish and bone meal, and compost. These organic fertilizers are decomposed by microorganisms in the soil to release their nutrients for use by plants. Chemical fertilizers are less complex and have high concentrations of chemicals that may be in short supply in the soil namely nitrogen, phosphorous, potassium, calcium, magnesium and sulfur. Fertilizers also provide micro nutrients which are required in much smaller quantities namely boron, chlorine, copper, iron, manganese, molybdenum and zinc.

The macronutrients are consumed in larger quantities and are present in plant tissue in quantities from 0.15% to 6.0% on a dry matter (0% moisture) basis (DM). Micronutrients are consumed in smaller quantities and are present in plant tissue on the order of parts per million (ppm), ranging from 0.15 to 400 ppm DM, or less than 0.04% DM. Only three other macronutrients are required by all plants: carbon, hydrogen, and oxygen. These nutrients are supplied by water and carbon dioxide. The nitrogen-rich fertilizer ammonium

nitrate is also used as an oxidizing agent in improvised explosive devices, sometimes called fertilizer bombs, leading to sale regulations.

### **Forms**

Fertilizers come in various forms. The most typical form is granular fertilizer (powder form). The next most common form is liquid fertilizer some advantages of liquid fertilizer are its immediate effect and wide coverage. There are also slow-release fertilizers (various forms including fertilizer spikes, tabs, etc.) which reduce the problem of "burning" the plants due to excess nitrogen.

**Fertilizers:** Fertilizer is any organic or inorganic material of natural or synthetic origin that is added to a soil to supply one or more plant nutrients essential to the growth of plants. A recent assessment found that about 40 to 60% of crop yields are attributable to commercial fertilizer use.

Inorganic fertilizer is synthesized using the Haber-Bosch process, which produces ammonia as the end product. This ammonia is used for other nitrogen fertilizers, such as anhydrous ammonium nitrate and urea. Now fertilizers with slow release of nutrients have been developed.

Appropriate use of fertilizers to increase crop yield has counterbalanced loss of land due to urbanization and significantly supported global population growth, It has been estimated that almost half the people on the Earth are currently fed as a result of synthetic nitrogen fertilizer use.

Fertilizers are broadly divided into organic fertilizers (composed of enriched organic matter plant or animal), or inorganic fertilizers (composed of synthetic chemicals and/or minerals).

Inorganic fertilizer is often synthesized using the **Haber-Bosch** process, which produces ammonia as the end product. This ammonia is used as a feedstock for other nitrogen fertilizers, such as anhydrous ammonium nitrate and urea. These concentrated products may be diluted with water to form a concentrated liquid fertilizer (e.g. UAN). Ammonia can be combined with rock phosphate and potassium fertilizer in the Odda Process to produce compound fertilizer.

The use of synthetic nitrogen fertilizers has increased steadily in the last 50 years, rising almost 20-fold to the current rate of 100 million tonnes of nitrogen per year. [Ghabbour and Davies 2004] The use of phosphate fertilizers has also increased from 9 million tonnes per year in 1960 to 40 million tonnes per year in 2000. A maize crop yielding 6-9 tonnes of grain per hectare requires 31–50 kg of phosphate fertilizer to be applied, soybean requires 20–25 kg per hectare [Dutta 2010]. Yara International is the world's largest producer of nitrogen based fertilizers. [Dutta, R. L. and De, G. S., 2013]

Cereals are an important dietary protein source throughout the world, because they constitute the main protein and energy supply in most countries (Bos et al. 2005). Wheat is one of the major cereal crops with a unique protein, which is consumed by humans and is grown around the world in diverse environments. Wheat seed-storage proteins according to their solubility properties are traditionally classified into four classes; albumins, globulins, prolamins and glutelins.

Gluten, the most abundant wheat endosperm protein, is a large complex mainly composed of polymeric and mono-meric proteins known as glutenins and gliadins, respectively (MacRitchie 1992). It has already been known that gluten proteins have a premier role in wheat flour quality. It is recognized that variation in protein content and composition

significantly affect wheat quality with a subsequent influence on baking properties (Johansson et al. 2001). Wheat protein content and baking quality highly depend on genetic background and environmental factors, especially influence of drought and heat stress, during the grain filling period and nitrogen availability (soil N, rate and time of N application) (Tea et al. 2004). Nitrogen rate, type of nitrogen, and timing of its application are important factors to increase wheat yield (Garrido-Lestache et al. 2005). Furthermore, N fertilization is useful to enhance the baking quality parameters such as protein content and protein quality (Grant et al. 2001). Some studies showed that N fertilization increases the total quantity of flour proteins, resulting in an increase in both gliadins and glutenins (Johansson et al. 2004). The use of chemical fertilizers has been increased worldwide for cereal production (Abril et al. 2007) due to availability of inexpensive fertilizers (Graham and Vance 2000). The continued use of chemical fertilizers causes health and environmental hazards such as ground and surface water pollution by nitrate leaching (Pimentel 1996). So, reducing the amount of nitrogen fertilizers applied to the field without a nitrogen deficiency will be the main challenge in field management. One of the possible options to reduce the use of chemical fertilizer could be recycling of organic wastes. Compost as the organic waste can be a valuable and inexpensive fertilizer and source of plant nutrients. Positive effects of organic waste on soil structure, aggregate stability and water-holding capacity were reported in several studies (Jedidi et al. 2004 and Odlare et al. 2008). Furthermore, compost has a high nutritional value, with high concentrations of especially nitrogen, phosphorus and potassium, while the contamination by heavy metals and other toxic substances are very low (Asghar et al. 2006). Previous studies showed that the combination of compost with chemical fertilizer further enhanced the biomass and grain yield of crops (Sarwar et al. 2008).

The use of inorganic fertilizers can improve crop yields, soil pH, total nutrient content and nutrient availability (Akande et al., 2010); most especially in the tropics where soils are adversely affected by sub-optimal soil fertility and erosion causing deterioration of the nutrient status and changes in population of soil organisms (Economic Commission for Africa, 2001). But its use is constrained by acidity, scarcity, nutrient imbalance and it is no longer within the reach of poor-resource farmers due to its high cost. When excessively used, it also has a depressing effect on yield. This causes a reduction in number of fruits, delays and reduces fruit setting (John et al., 2004).

India is an agriculture base country. To provide food to everyone, there is tremendous pressure on cultivable land to grow more food and other agricultural products. The production of food and other agricultural products is largely influenced by the fertility and the nature of soil. Soil is an independent, dynamic body of nature that acquires properties in accordance with the forces act upon it. The properties of soil not only depend upon the type of parent rock but also on the environmental factors like climate, vegetation, topography and time of weathering or reaction with atmospheric agencies. Soils are composed of two groups of materials, viz. Mineral matter and organic matter. Their properties vary widely according to the percentage ratio of mineral and organic matter. Fertility of soil mainly depends upon the amount of organic matter or humic substance present in it. Humic substances in soil come from the decomposition products of plants and animal. Organic matter in the soil supplies nutrients to the microorganism present in the soil. Plants supply us food, oxygen and other necessities of life. All the animals directly or indirectly live on plants. Thus all animal food including milk is obtained from plants. The

plants, so essential for our life require some food for their own nourishment. The food materials build up the body of the plant which contains carbohydrates, proteins, lignin, and other organic matter. Carbon, oxygen and hydrogen are supplied by carbon dioxide and water. The nitrogen is supplied by nitrates, which are ultimately produced in the soil. Some plants may also sustain themselves by ammonia. Plants also require phosphates and potassium salts for their growth. All these plant food are supplied by nature. Carbon dioxide and some moisture are taken from the air, most of the water and salts are taken from the soil by roots of the plants. Oxygenation of the roots and other parts of the plants are also essential for plant metabolism. The food materials derived from the soil are known as fertilizers or manures. Each year these fertilizers are depleted from the soil and they are to be replenished every year. Application of the fertilizers to the soil increases fertility of the soil, hence plant products have to be sustained on normal level by applying larger amount of fertilizers. At the present time, this increase of food production has become urgent owing to the enormous growth of population of the World. Generally, the nitrogenous fertilizers are replenished by the nitric acid produced by lightning, and by the organic manure- the cattle excreta, the plant and animal decomposition products, etc. The phosphates fertilizers are replenished from animal bones, farm yard manure, plant and animal decomposition products.. Potassium fertilizers are replenished by wood ash, and plant decomposition products [Vanloon et al.,2011 and Das 1987]. Different type of fertilizer: But the natural fertilizers discussed above are limited in amount, moreover much of them are withdrawn from their use as fertilizers, being used as fuel in the countryside (in India) natural source of fertilizers can not cover up with the ever increasing demand for fertilizer for growing two to three crops in a year from a particular piece of a land. Hence it is necessary to add synthetic fertilizers along with farm yard manure to the soil in order to maintain and increase the fertility of the soil. So synthetic ammonia plants have come up in different parts of our country to replenish the deficit by producing urea, ammonium sulphate etc. In India 90% of the ammonia produced is utilised for making nitrogenous fertilizer. The nitrogenous fertilizers usually used are ammonium sulphate, double salt mixture of ammonium sulphate and ammonium nitrate, ammonium nitrate, calcium ammonium nitrate and urea etc. Other artificial fertilizers used in India are superphosphate of lime, triple phosphate, rock phosphate, ammonium phosphate, ammoniated superphosphate and nitro-phosphate and di-calcium phosphate etc. Ammonium sulphate is manufactured by first manufacturing synthetic ammonia by Haber process. Ammonia is then allowed to react with sulphuric acid or with gypsum powder and carbon dioxide. Double salt is prepared by mixing ammonium sulphate and ammonium nitrate. Ammonium nitrate is made by the reaction between nitric acid and ammonia. Nitric acid is synthesized by Ostwald's process. Urea is prepared from synthetic ammonia and carbon dioxide. Super phosphate of lime is made by the reaction between rock-phosphate and sulphuric acid. Double superphosphate is prepared by the reaction between rock-phosphate and phosphoric acid [Das 1987 and Kreiger 2009].

### **Pesticides and Insecticides**

In order to minimize the damage of the crops by pests a large variety of chemicals known as pesticides are used. Subclasses of this are herbicides, insecticides, fungicides, rodenticides, pediculicides, and biocides depending on its target. With active research in this field safer and greener pesticides are being developed. Insecticides are chemicals that are used to kill insect because they can spread



livestock diseases, can eat stored grain, and can feed on growing crops. However not all insects are harmful, and certain species of insects are needed to pollinate plants to ensure that they set seed.

These chemicals prevent crop losses to insects and other pests. One study found that not using pesticides reduced crop yields by about 10%. Crop protection chemistry has come a long way from its "alchemic" beginnings in the late 19th century to a high-tech science that supports the sustainable production of food, feed, and fiber for a rapidly growing population. Cutting-edge developments in the design and synthesis of agrochemicals help to tackle today's challenges of weed and pest resistance, higher regulatory safety margins, and higher cost of goods with the invention of selective, environmentally benign, low use rate, and cost-effective active ingredients.(e.g. alachlor). Phenoxy compounds tend to selectively kill broadleaved weeds rather than grasses. The phenoxy and benzoic acid herbicides function similar to plant growth hormones, and grow cells without normal cell division, crushing the plants nutrient transport system.[8]:300 Triazines interfere with photosynthesis. Many commonly used pesticides are not included in these families, including glyphosate.

Pesticides can be classified based upon their biological mechanism function or application method. Most pesticides work by poisoning pests. A systemic pesticide moves inside a plant following absorption by the plant. With insecticides and most fungicides, this movement is usually upward (through the xylem) and outward. Increased efficiency may be a result. Systemic insecticides, which poison pollen and nectar in the flowers, may kill bees and other needed pollinators.

In 2009, the development of a new class of fungicides called paldoxins was announced. These work by taking advantage of natural defense chemicals released by plants called phytoalexins, which fungi then detoxify using enzymes. The paldoxins inhibit the fungi's detoxification enzymes. They are believed to be safer and greener.

Fungicides are used to control infestations of fungi, and they are generally made from sulfur compounds or heavy metal compounds. Fungicides are used primarily to control the growth of fungi on seeds. They are also used on mature crops, although fungal infestation is harder to control at this later stage.

Herbicides are weed killers that are used to destroy unwanted plants. Generally herbicides are very selective, since they would be useless for most applications if they were not. A general non-selective herbicide can be used to clear all plants from a particular area. However, appropriate treatment must be carried out to remove the herbicide or render it ineffective if that area is to be used for subsequent plant growth. Herbicides can be used to kill weeds that grow among crops and reduce the value of the harvest. They can also be used to kill plants that grow in fields used for grazing by animals, since some plants can be poisonous to livestock or can add unpleasant flavors to the meat or milk obtained from the livestock. Breeding and genetic manipulation are used to introduce herbicide resistance to crops, allowing the use of more broad-spectrum herbicides that can kill more weed species with a single application. Herbicides include a wide range of compounds, such as common salt, sulfates, and ammonium and potassium salts. In the 1940s 2,4-D (2,4 trichlorophenoxyacetic acid) was developed and this herbicide is still widely used today.

Insecticides are chemicals that are used to kill insect pests. Insects can spread livestock diseases, can eat stored grain, and can feed on growing crops. Not all insects are harmful, and certain species of insects are needed to pollinate plants to ensure that they set seed.



Insecticides work in a number of ways. Some are direct poisons (chrysanthemic acids, contact poisons, systemic poisons), while others are attractants or repellents that move the insects to a different location (fumigation acrylonitrile). Some insecticides will only attack a particular stage of an insect's life cycle and this can make them more specific.

Pesticides can save farmers' money by preventing crop losses to insects and other pests; in the U.S., farmers get an estimated fourfold return on money they spend on pesticides. One study found that not using pesticides reduced crop yields by about 10%. Another study, conducted in 1999, found that a ban on pesticides in the United States may result in a rise of food prices, loss of jobs, and an increase in world hunger.

Agricultural chemistry has provided us with more and cheaper food than ever before. It has also allowed food to be produced in areas that previously were unsuitable for agriculture. The application of chemicals to farming has been one of the chemical success stories of the twentieth century.. For example, sulfur dioxide can be used to keep grain fresh and useable for a longer period of time than untreated grain. Other chemicals can be added to promote the ripening of fruits or the germination of seeds. It is difficult to estimate the monetary value of agricultural chemicals, but many multi- national corporations are involved in their manufacture and use. Agricultural chemistry has increased the diversity of the human diet and has led to a greater overall availability of food, both animal and plant.

#### **Chemistry in other areas of agriculture**

**Plastic pipes for improved irrigation:** Plastic was derived from chemistry and this is widely used in agriculture. This has increased irrigation massively which results in a better environment for the crops to prosper in.

**Storage and preservation of agriculture produce:** Sulfur dioxide is used to keep grain fresh and useable for a longer period of time. Food preservatives like sodium benzoate and salicylic acid are used for longer shelf life. New generation refrigerants have been developed. Chemicals are added to promote the ripening of fruits or the germination of seeds. Food packaging has advanced due to the material produced by advancements in chemistry. Agricultural chemistry has increased the diversity of the human diet and has led to a greater overall availability of food, both animal and plant.

**Food Processing:** Development of Saccharin and sweeteners, Vitamins and minerals. Consumers have benefited from new technologies that have enhanced the flavor, appearance, availability, and nutritional value of their food.

**Chemicals from agriculture waste:** Advancement in Chemistry has resulted in development of technologies to produce a variety of chemicals from agricultural waste. Production of alcohol from bagasse which is used as the feedstock for chemicals is good example,

#### **Conclusion**

Thus Chemistry has been and is still closely linked to the progress in agriculture field. Use of pesticides has been appreciated by farmers to increase crop production. In a tropical country like ours, the vegetables and crops are attacked by pests, fungus, bacteria, insects etc. and there is enormous growth of weed specially during rainy season. So, the use of pesticides, insecticides, herbicides, fungicides is also increasing. In most of the cases, they are used in undesirable amount. All these chemicals and salts present in the soil are washed by water to affect aquatic life and finally they travel through all compartments of environment. It provides innovative new ways to widen the boundaries of agriculture and to combat potential problems and thus increasing productivity and quality of produce.

## References

- Abedi,A., Alemzadeh A and Seyed Abdolreza Kazemeini 2018.Effect of organic and inorganic fertilizers on grain yield and protein banding pattern of wheat Australian Journal of Crop Science. 4(6):384-389 (2010).
- Abril A, Baleani D, Casado-Murillo N, Noe L (2007) Effect of wheat crop fertilization on nitrogen dynamics and balance in the Humid Pampas, Argentina. *Agric Ecosyst Environ* 119: 171-176.
- Akande, M.O and J.A. Adediran. 2004. Effects of terralyt plus fertilizer on growth, nutrient uptake and dry matter yield of two vegetable crops. *J. Agri. R.*,5:12-107.
- Annual report, 2002: Economic Commission for Africa 2001.
- Asghar HN, Ishaq M, Zahir ZA, Khalid M, Arshad M (2006) Response of radish to integrated use of nitrogen fertilizer and recycled organic waste. *Pak J Bot* 38: 691-700.
- Bos C, Juillet B, Fouillet H, Turlan L, Dare S, Luengo C, N'tounda R, Benamouzig R, Gausseres N, Tome D, Gaudichon C (2005) Postprandial metabolic utilization of wheat protein in humans. *Am J Clin Nutr* 81: 87-94.
- Bos, C., B. Juillet, H. Fouillet, L. Turlan, S. Dare, C. Luengo, R. N'tounda, R. Benamouzig, N. Gausseres, D. Tome. and C. Gaudichon. 2005. Postprandial metabolic utilization of wheat protein in humans. *The American Journal of Clinical Nutrition* 81: 87-94.
- Chhibbe V. K. 2017. Role of Chemistry in Agriculture.
- Chitra Joshi 2011. ROLE OF CHEMISTRY IN FEEDING GROWING WORLD POPULATION
- Chitra Joshi 2011. ROLE OF CHEMISTRY IN FEEDING GROWING WORLD POPULATION
- Das, R. K.,(1987). Industrial chemistry, Kalyani publishers, New Delhi. 4. Krieger, R.,(2009). Handbook of pesticide toxicology, academic Press, San Diego.
- Dutta, P. K., (2010).General & Inorganic Chemistry, 15th edn., Levant Books, Kolkata.
- Dutta, R. L. and De, G. S., (2013).Inorganic chemistry, 7th edn., The New Book Stall, Kolkata.
- Ghabbour, E. and G. Davies (eds.), Humic substances: Nature's most versatile materials, Taylor & Francis, New York; 2004.
- Garrido-Lestache EL, L'opez-Bellido RJ, L'opez-Bellido L (2005) Durum wheat quality under Mediterranean conditions as affected by N rate, timing and splitting, N form and S fertilization. *Europ J Agron* 23: 265–278.
- Graham PH, Vance CP (2000) Nitrogen fixation in perspective: an overview of research and extension needs. *Field Crops Res* 65: 93- 106.
- Grant CA, Brown KR, Racz GJ, Bailey LD (2001) Influence of source, timing and placement of nitrogen on grain yield and nitrogen removal of durum wheat under reduced and conventional tillage management.*Can. J. Plant Sci* 81: 17– 27.
- Jedidi N, Hassen A, Van Cleemput O, M'Hiri A (2004). Microbial biomass in a soil amended with different types of organic wastes. *Waste Manag Res* 22: 93–99.
- Johansson E, Prieto-Linde ML, Svensson G (2004) Influence of nitrogen application rate and timing on grain protein composition and gluten strength in Swedish wheat cultivars. *J Plant Nutr Soil Sci* 167: 345–350.

- Johansson, E., Prieto-Linde, M. L. and Jönsson, J. Ö. (2001). Effects of wheat cultivar and nitrogen application on storage protein composition and bread-making quality. *Cereal Chemistry* 78, 19-25.
- John, L. W., Jamer, D. B. Samuel, L. T., Warner, L.W. (2004), Soil fertility and fertilizers: an introduction to nutrient management. Person Education, 106–153. Delhi.
- Keith Smith, David A Evans, and Gamal A El-Hiti. 2008. Role of modern chemistry in sustainable arable crop protection. *Philos Trans R Soc Lond B Biol Sci.* Feb 12; 363(1491): 623–637.
- Krieger, R., (2009). Handbook of pesticide toxicology, academic Press, San Diego.
- MacRitchie F (1994) Physicochemical properties of wheat proteins in relation to functionality. *Adv Food Nutr Res* 36:1-87.
- Odlare M, Pell M, Svensson K (2008) Changes in soil chemical and microbiological properties during 4 years of application of various organic residues. *Waste Manag.* 28: 1246-1253
- Pimentel D (1996) Green Revolution and chemical hazards. *Sci Total Environ* 188: 86-98.
- Safalla Kr and Ghosh 2015. Application of Synthetic Chemicals in Agriculture and their toxic effect on the Environment. *Bulletin of Environment, Pharmacology and Life Sciences.* Vol 4 [9]: 01- 06.
- Safalla Kr. Ghosh. Application of Synthetic Chemicals in Agriculture and their toxic effect on the Environment *Bulletin of Environment, Pharmacology and Life Sciences Bull.Env.Pharmacol.Life Sci.,* Vol 4 [9] August 2015: 01- 06.
- Sarwar G, Hussain N, Schmeisky H, Muhammad S, Ibrahim M, Safdar E (2008) Improvement of soil physical and chemical properties with compost application in rice-wheat cropping system. *Pak J Bot* 40: 275-282.
- Sylvester R. Atijegbe1, Babatunde O. Nuga, Ndowa E. S. Lale, and Ruth N. Osayi 2014. Effect Of Organic And Inorganic Fertilizers On Okra (*Abelmoschus esculentus* L. Moench) Production And Incidence Of Insect Pests In The Humid Tropics. *IOSR Journal of Agriculture and Veterinary Science (IOSR-JAVS).* Volume 7, Issue 4 Ver. III . 25-30
- Tayebbeh Abedi, Abass Alemzadeh and Seyed Abdolreza Kazemeini 2010. *Australian Journal of Crop Science.* 4(6):384-389.
- Tea I, Genter T, Naulet N, Boyer V, Lummerzheim M, Kleiber D (2004) Effect of foliar sulfur and nitrogen fertilization on wheat storage protein composition and dough mixing properties. *Cereal Chem* 81: 759–766.
- Vanloon, G.W. and Stephen J. Duffy, (2011). *Environmental Chemistry*, 3rd edn., Oxford University Press, New York.

## **A Study of Consumer Perception towards Retail Outlets in Bhopal City**

**Barkha Gupta\***

**Dr. Swarna Parmar\*\***

### **Abstract**

The retail business is the biggest business in India. The retail idea is developing definitely with new arrangements like general stores, grocery stores, shopping centers, hyper markets and claim to fame stores. Retailer is a man who communicates with both the producer and the Customer. To manage in retailing industry, retailers focus on creating and keeping up relationship with customers. Retailers have understood that for making customer faithful, they have to be faithful to the customer, as customers are the life saver of the retail business. India's retail business is relied upon to develop hugely in next couple of years. Retail industry in India is relied upon to rise 25% yearly being driven by solid salary development, evolving ways of life, and ideal demographic patterns. The consumer needs differ widely across the country. Distinct strategies should be adopted for different regions and different products. There is a need to analyze the perceptions of the shoppers towards the organized retail stores for making better strategic decisions. Hence, the study is undertaken with the main objective of analyzing the perception of the consumers towards the retail outlets in Bhopal (M.P.). To complete the purpose of study select few variables that influence consumers. The research design of this thesis is of descriptive nature and sample of the study were 100 which were collected by questionnaire survey method. Percentage, mean, standard deviation, graph and t- test methods were used for data analysis. Spss version 24 was used for calculation. The result found that selected variables influence consumer perceptions towards retail outlets.

### **1. Introduction**

Retailing services have become very significant in present economy. The retail outlets play a crucial role in the overall economy of India and contributing around 14 to 15 percent to our country GDP. Retailing is the final stage in a channel of distribution. Retailer is a person who interacts with both the manufacturer and the customer. He creates the link between the manufacturer, wholesaler and the end consumer. Over the last fifteen years, the Indian retailing industry has been experiencing phenomenal growth. In competitive market Retailers have positioned themselves for all kind of customer needs, because of this many retailers have been upgrading themselves by re-locating to upcoming modern malls and shopping centers, providing superior shopping atmosphere and experience especially in the urban and semi urban centers.

Retail outlet shopping has become increasingly popular, due to convenience (and often various offers). Retail shopping saves an individual the hassle of searching several stores because they can get each and every product like clothes, grocery, crockery, stationary and many more in only one roof top. Now consumers are looking for higher values and are seeking a fair return in goods and services for their hard earned money and scarce time.

---

\* Research scholar, Jiwaji University, Gwalior (MP)

\*\* Assistant Professor, SOS in Management, Jiwaji University, Gwalior (MP).

They want products or services that meet their specific needs or wants and that are offered at competitive prices. Firms should endeavor to locate the most attractive harmony between giving advantages to shoppers and holding their expenses down. Retailing acts as an interface between producers and consumers and it help to raise the efficiency of distribution in an economy. In retailing customer regarded as king and there is need to identify the customer perception towards retail outlets.

Thus like any other service industries, the retail industry of India also needs the attention of practitioners to ensure high service quality. In the present retailing market, buyer shopping behavior, consumer loyalty and customer retention have turned out to be real determinants achievement, which can be guaranteed by service quality offered by the retail outlets.

Retail industry some how depend on consumer's perception towards it. If retail store provide all essential things regarding customer suitability so its accept by consumer and they purchasing from there. The term "Perception" is derived from the word "Perceive", it means the ability of an individual to give meaning to whatever he sensed by his sensory organs. It is the method by which an individual understand one's sensory impressions to give meaning to them. Perception is founded on one's knowledge and belief about the world. The behavior of an individual largely depends upon the way he pursues himself and the world around him. Perception refers to the way in which an individual experiences the surroundings world. Every individual's lifestyle is different. Therefore, Perception of an individual is based upon the behavior he displays to understand the world. The perception is the formed as a result of interpreting the experience. Therefore growing interest in understanding the users' experience is essential for retail outlets.

The paper therefore identifies factors that work as a strength of retail outlet that help to influence the purchase decisions of consumers in the emerging retail outlets. For this study five variables namely "Quality and services, easy availability of goods, discount and offer provided to customers, organization environment, policies and schemes" are taken to judge customer perception

## **2. Definition**

1. **Schiffman** – Customer perception is "the process by which an individual selects, organizes, and interprets stimuli into a meaningful and coherent picture of the world."
2. **Philip kotler**, "Retailing includes all the activities involved in selling goods or services to the final consumes, for personal, non-business use. A **retailer** or **retail** store is any business enterprise wholesales volume comes primarily from **retailing**.

## **3. Objectives**

The specific objectives of the study were:

1. To identify the factors influencing customers shopping decisions.
2. To study the perception of the consumer toward retail outlets.

## **4. Research Hypotheses**

**H0-** There is no positive significant relationship between factors influencing consumer used by retail outlets and consumer perception.

**H1-** There is positive significant relationship between factors influencing consumers used by retail outlets and consumer perception.

## **5. Literature Review**

A study conducted in Bangladesh to identify the customers' expectation & perception towards organized retail sector and find out the level of customer satisfaction in Chittagong city. The research has been conducted among the customers of organized retail outlets in



Chittagong i.e Meena bazar, Agora, & Swapno. The size of the sample was 85 for this study. Arithmetic mean & z-test were applied for this research. The researcher wants to explore the gap between the expected and actual service quality in the superstores of Bangladesh. The output of study said that there is a significant difference between customer expectation and customer perception regarding the dimensions on retail chain services in Chittagong. (Md. Alauddin, 2016)

A study conduct in **Sangli City**, This paper analyzes the perception of the people towards retail outlet D-mart in Sangli city. Sample size of this study was 50 respondents comes from different age, Education & Budget groups. Further this paper focus on the people's perception regarding the preferred purchase items, most important factors which affects on the shopping decision and satisfaction level towards products and services offered by the retail store. Statistical analysis reveals that the perception of the consumers was vary to a large extent according to age, their Education and Budget. **(M.M.Joshi, P.A.Petare)**

According to K. K. Das and Priyanka Tripathy (2015), a study conducts in Odisha urban retail format consumers. The purpose of the research paper intends to identify the (sectorspecific) store image attributes and evaluate the strength and importance of the influence of each attribute on the purchase decision of Odisha urban retail format consumers. Sample size 601 consumers served as the convenient sample. The correlation between the demographic variables and the various store image attributes were highly significant. This holds much importance for retailers in today's volatile marketplace and relates to the need for retailers to take into account the impact of retail store image and its relationship with store loyalty.

Azhagan & Nagarajan (2011) analyzed that "a large portion of the customers prefer Organized Retail sector because of more Tangibles and Empathy towards its customers. Keeping in mind the end goal to hold and pull in new clients, the sorted out retail area ought to enhance customer's benefit level and ought to give affirmation towards its customer." Singh (2013) expressed that "In retailing apparent administration quality is affecting obtaining and repurchasing choices, positive verbal exchange and also on whining conduct in retailing"

## **6. Variables used for the Study**

- 1. Dependent variable**-Consumer perception taken as a dependent variable for this study.
- 2. Independent variables**- factors influencing customers used by retail outlets were taken as independent variables for this study

So, factors influencing customers used by retail outlets were-

- a. Quality and services
- b. Easy availability of goods,
- c. Discount and offer provided to customers,
- d. Organization environment,
- e. Policies and schemes

## **7. Research Methodology**

### **7.1 Research Design**

The main aim of this survey is to analyses customers` perception towards retail outlets in Bhopal region. Therefore, descriptive research designs taken as research design.

### **7.2 Area of the study**

The study is conducted among all class of customers who are the regular purchasers and occasional buyers in retail outlets in Bhopal region.



### 7.3 Research Approach

To collect Primary data structured questionnaire was designed which was divided under three heads i.e. General questions, Factors of attracting customers related questions and demographics questions. In first part respondents were asked to reveal their shopping behavior general questions. In second part respondents were asked to evaluate parameters of retail outlet activities that attract for shopping in retail outlet on a 5 point Likert's scale, for checked the perception. In third Part respondents were asked to reveal their personal characteristics i.e. gender, age, education & occupation.

### 7.4 Sampling

The size of the sample was 100 & Convenience method was adopted for sampling.

### 7.5 Analytical Tools

For analysis and interpretation data tabulation, graph, Arithmetic mean, standard deviation & t-test were applied by using Spss version 24.

## 8. Analysis & Interpretations

### 8.1 Demographic profile of respondents

**Table 1: Respondents' Profile**

(n)=100

Variables	Frequency	Percentage
<b>1.Age</b>		
Below 20	NA	NA
20 to 24	33	33%
25 to 29	44	44%
30 to 34	13	13%
35 to 40	02	02%
Above 40	08	08%
<b>Gender</b>		
Male	39	39%
Female	61	61%
<b>Education level</b>		
Undergraduate	09	09%
Graduate	34	34%
Postgraduate or higher	57	57%
<b>Occupation</b>		
Business	17	17%
Services	53	53%
Housewife	19	19%
Retired	08	08%
Other	03	03%
<b>Average Monthly Purchase at Retail Outlet</b>		
Less than 2000rs.	25	25%
2001rs. – 4000rs.	30	30%
4001rs. – 6000rs	25	25%
More than 6000rs.	20	20%

Source: Primary data

**Interpretation**

A total of 100 questionnaires were collected by respondents who were purchaser or customer of retail outlets in Bhopal city, in January 2018. As per shown in table 1, Demography characteristics of the responses of the Respondent, were classified according to their gender, education, age & average monthly purchase from retail outlet. Out of total respondents 44% respondents belong to the age group of 25 to 35 years. 61% are male & rests are female. Majority of respondents are post graduate and higher (57%). Majority of respondents (30%) spend rs.2001 to rs. 4000 of their monthly budget towards their purchase in organized retail store.

**8.2 General questions analysis**

**8.2.1. Number of people who are like to do shopping.**

**Table-2**

Particulars	No. of Respondents	Percentage
Yes	100	100%
No	0	0

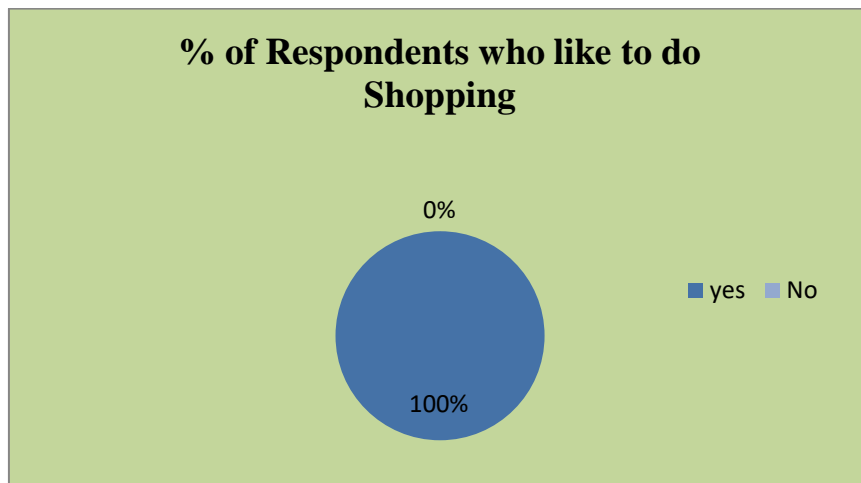

**Interpretation**

As the pie chart shows, out of sample size 100 of all the consumers are like to do Shopping. As the graph shows 100% people are like to do shopping.

**8.2.2. Frequency of visits retail outlets by respondents.**

**Table-3**

Category	No. of respondents	Percentage (%)
Weekly	20	20%
Monthly	40	40%
15-20 days	38	38%
Rarely	02	02%

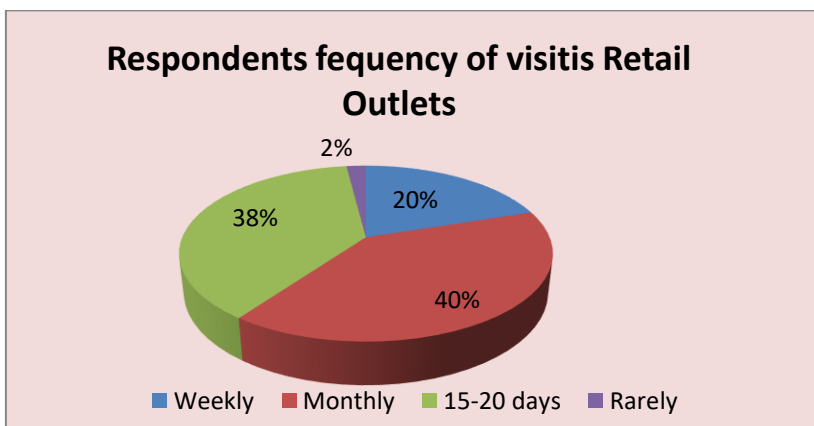

**Interpretation**

As the pie chart shows 20% people are likely to do shopping weekly. 40% Peoples are likely to do shopping on monthly basis. 38% of people like to do shopping on 15-20Days basis. And out of sample, only 2% is there who likes to do shopping rarely. It means most of the people like to do the shopping at monthly and 15-20 days basis.

**8.2.3. Preferred retail outlet by respondents**

**Table 4**

Name of retail outlets in Bhopal region	No. of respondents	Percentage (%)
Bigbazaar	40	40%
Vishal Mega Mart	30	30%
Reliance Smart	07	07%
Aapurti Store	08	08%
D mart	15	15%
Others	0	0

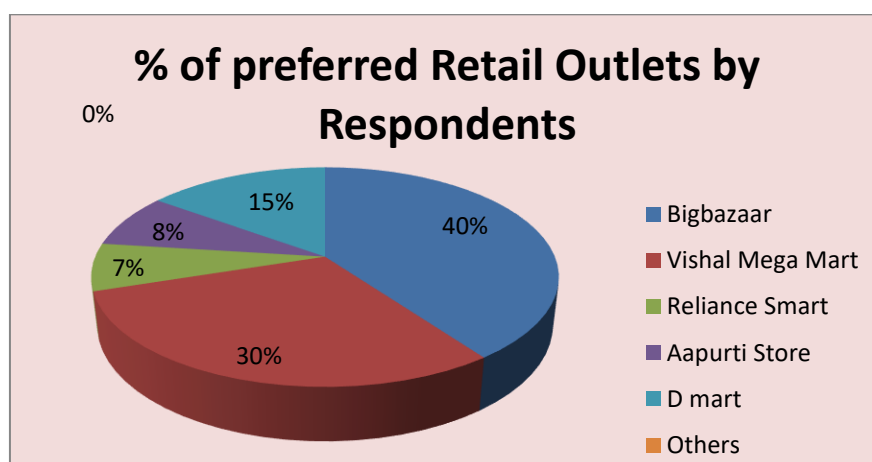

**Interpretation**

As the pie cart show 40% respondents like to do shopping with bigbazaar in Bhopal region. 40% respondents preferred vishal mega mart, 15% respondents choose D mart and 8% & 7% respondents like to do shopping with aaurti store and reliance store respectively. As result show most of the respondent's preferred bigbazaar and vishal mega mart in Bhopal region, M.P.

### 8.3 Data analysis for hypothesis

#### 8.3.1 Reliability testing

Testing the reliability of the questions that used Likert's Scale showed that data from this research was reliable with Cronbach's alpha value of at least 0.70. The data of the study get Cronbach's alpha value is 0.795, so data is reliable for study.

#### 8.3.2 Factors influence consumers in retail outlets in Bhopal (M.P.)

To analyze the factors one sample t- test were used on data and SPSS version 24 were used as statistical tool for this calculation.

#### T- test analysis for variables-

This bellow table shows the summary of result of one sample t- test for this research.

Here, N= 100

Df=99

**Table 5- Retail outlet factors influence on consumers perceptions in Bhopal Region.**

Test Value = 3							
S.No.	Retail outlet factors influence consumers	Parameters	Mean	SD	T	Sig. (2-tailed)	Observation
1.	Quality and services.	Satisfaction with the product services and quality that purchase at right price from retail outlet.	3.87	0.525	t=16.564	.000	Significant P< .05
2.		Retail outlets employees provide good services whenever required.	3.97	0.501	t=19.338	.000	Significant P< .05
3.	Easy availability of products	Retail outlet prefer for shopping because almost all the products including grocery, vegetables, dairy product etc. are available under one umbrella.	3.91	0.739	t=12.300	.000	Significant P< .05
4.		Easily compare the different products before purchase.	3.79	0.756	t=10.449	.000	Significant P< .05
5.	Discounts and Offers	Different discounts and offers attract to do shopping with retail outlets.	3.87	0.812	t=10.711	.000	Significant P< .05
6.		Retail outlets offers and discounts provide full value of money while shopping.	3.96	0.777	t=12.348	.000	Significant P< .05

7.	<b>Organization environment</b>	Retail outlets environment keep fresh while shopping.	3.69	0.525	t=13.118	.000	Significant P< .05
8.		Retail outlet environment make shopping more simple, easy and convenient.	3.74	0.561	t=13.173	.000	Significant P< .05
9.	<b>Policies and schemes</b>	Retail outlets return and exchange policies are convenient.	3.8	0.471	t=16.971	.000	Significant P< .05
10.		Retail outlets offer different attractive schemes at the time of payment that help to save money.	3.62	0.907	t=6.831	.000	Significant P< .05

Source- Calculated from primary data

**Interpretation**

The one sample t- test conducted with the help of SPSS 24 version software that taking all the variables into account like quality and services, easy availability of product, discount and offers , organization environment and policies & schemes in consumers of Bhopal region to check the consumer perception towards retail outlet. Table show that researcher chooses five variables for the study and each variable were include activities that perform by retail outlet for consumers. Result show that all selected factors were influence consumer perception in retail outlets.

**9. Discussion of the Findings**

**9.1. Quality and services**

This module has 2 questions that represent the quality and services provided by retail outlet to their customers. It was identified that quality and services of products was influencing consumer perception towards retail outlet in Bhopal region. Every customer want that he/she get good quality of product at right price and proper services after purchasing product and also get proper attention by retail outlet executive whenever they required. As show in the table that both the parameters 1 &2 had t = 16.564 and 19.338 respectively and both gave positive significant effect on customer perception because p value is 0.000 that is less than 0.05.

**9.2. Easy availability of products**

This module has two questions that represent the easy availability of products according to customer suitability in retail outlets in Bhopal region. The study sought to determine the effect of easy availability of product on customer perception. Retail outlet is a huge area where multipurpose products are available so it's properly design layout is must according to convenience for consumers. People come into the retail outlet because they want whatever they needs get in very short time of period. It's only possible when products easily available for consumers. As show in the table both the parameters 3 and 4 had t = 12.300 and 10.449 respectively. P value for both parameters had 0.000, that is p <0.05. So module-2 easy availability of products gave a positive significant effect on customer perception in retail outlets in Bhopal region.



### **9.3.Discounts & offers**

This is the third module of the research study. This module had two questions. Discounts and offers are the way to motivate people for shopping from retail outlet. Every people want to save money and they want good product at less price, so they take benefits from different offer. Retail outlets provide different discounts and offers to their customers. The study sought to determine the effect of discounts and offers on customer perception. As show in the table both the parameters 5 and 6 had  $t = 10.711$  and  $12.348$  respectively. P value for both parameters had  $0.000$ , that is  $p < 0.05$ . So module-3 Discounts & offers gave a positive significant effect on customer perception in retail outlets in Bhopal region.

### **9.4.Organization Environment**

This is the fourth module of the research study. This module has two questions. Organization environment is an important factor for retail outlets that attract customers. This factor gives a big effect on customer perception. In a fast running hectic life, when people go for shopping they want shopping will be enjoyable for them. Weather also gives impact on shopping, so people prefer air-conditioner shopping experience with their near and dear ones, they want fresh environment so they do shopping cheerfully. The study sought to determine the effect of organization environment on customer perception. As show in the table both the parameters 7 and 8 had  $t = 13.118$  and  $13.173$  respectively. P value for both parameters had  $0.000$ , that is  $p < 0.05$ . So module-4 organization environment gave a positive significant effect on customer perception in retail outlets in Bhopal region.

### **9.5.Policies and schemes**

This is the last fifth module of the research study. This module also has two questions. Every organization has its own policies and timely scheme for their customers. This polices and schemes made some rules regarding products and services purchased by customers. For example exchange policies, return policy, online pay provide cash back, schemes with terms and condition etc. The study sought to determine the effect of Policies and schemes on customer perception. As show in the table both the parameters 9 and 10 had  $t = 16.971$  and  $6.831$  respectively. P value for both parameters had  $0.000$ , that is  $p < 0.05$ . So module-5 Policies and schemes gave a positive significant effect on customer perception in retail outlets in Bhopal region.

### **10. Testing of hypothesis**

There were one null hypothesis and one alternative hypothesis to be tested. This was done based on the results of Table. The results are given below.

**Null hypothesis said that“H0-** There is no positive significant relationship between factors influencing consumer used by retail outlets and consumer perception.” According to the table null hypothesis were rejected for this study because every factor influence consumer perception so there had relationship between them.

**Alternative hypothesis said that “H1-** There is positive significant relationship between factors influencing consumer used by retail outlets and consumer perception.” According to the table alternative hypothesis for this study were accepted because every factor influence consumer perception so there had relationship between them.

### **11. Conclusion and suggestions**

The study revealed that Retail chain sector is a growing sector and effectively design retail outlet can bring lots of benefits to the organization. Effectively design retail outlet can bring lots of customers. Consumer perceptions are very important to develop this sector in

Bhopal (M.P.). However, it is also true that if retail sector not focus on the factors that influence consumer, at that point consumer may create negative perception about that retail outlet and this has negative impact on organization growth and consumer's mind also. So regular monitoring and proper focus on "factors influencing customer" help to create positive perception of customers towards retail outlets.

Understanding the right attribute in respect of different types of consumers segregated by gender, age, education, occupation and income spend in one month in shopping is important to the retailer because the identified attribute can support consumers and will ultimately facilitate the retail strategy.

Apart from that few points should be focus by the retailer like, employees of retail outlets should be trained to handle the customers" complaints effectively. Proper training must develop the skills of employees in Retail outlets. Employees of retail outlets should have sufficient knowledge about products available in store so that they can answer any query of customers. The Retail outlets should try and focus on the specific demands of its customers. This will help it to differentiate itself from the others and will provide customers with better satisfaction. Adequate publicity material should be available to customers. This material should contain relevant and accurate information about the facilities available at the retail outlet. Particular attention should be given to the appearance and quality of such communication material. Employees should receive proper training on professional communication with customers. Employees should be encouraged to give personal attention to customers by addressing them by name whenever and wherever possible.

According to the research output it is clear that factors influencing customers in retail outlets namely "Quality and services, easy availability of products, discounts and offers, organizational environment and policies & schemes" gave positive effect on consumer perceptions.

### **Bibliography**

1. An article on "Consumer perception and attitude towards organized and unorganized retailoutlets",[http://shodhganga.inflibnet.ac.in/bitstream/10603/175565/10/10\\_chapter3.pdf](http://shodhganga.inflibnet.ac.in/bitstream/10603/175565/10/10_chapter3.pdf)
2. Azhagan, T., & Nagarajan, D. P. (2011). Analytical Study On Retail Service Quality Of Organized Retail Sector In Trichy. *AmetJournal of Management*, 75-83.
3. Chaudhary Sandeep, Sharda Shruti (jan 2017)," Consumer Perception towards Organized Retail Store: A Factor Analytical Approach" *Pacific Business Review International* Volume 9 Issue 7, pp 14-23
4. Das K. K., Tripathy Priyanka (2015)," Consumer Perception Towards Retail Store Image: A Study of the Emerging Retail Formats in Urban Odisha", *International Journal of Research and Development - A Management Review (IJRDMR)*, Volume-4, Issue-4,pp 31-38, ISSN (Print): 2319-5479
5. Dr. C.Vethirajan, S. Jayakumar (2016)," Crm Practices And Customers` Perception Towards Retail Outlets In Puducherry", *Indian journal of applied research*, Volume : 6 ,Issue : 7,pp 548-551, ISSN - 2249-555X
6. Dr. M. Rajesh, G Purushothaman (2013),"Consumer perception towards online shopping in Kanchipuram", *GALAXY International Interdisciplinary Research Journal*, Vol.1 (2),pp 36-44, ISSN 2347-6915

7. Dr.R.Shanthi, Dr. Desti Kannaiah (2015).” Consumers’ Perception on Online Shopping”, Journal of Marketing and Consumer Research, Vol.13, pp 14-20, ISSN 2422-8451
8. Joshi M.M., Petare P.A., a research paper on “A Consumer Perception towards Retail Outlet With reference to D-MART in Sangli City” , [www.researchgate.net](http://www.researchgate.net)
9. Md. Alauddin (July 2016),” Customer Expectation And Perception Towards Retail Chain: An Evaluative Study”, IOSR Journal of Business and Management (IOSR-JBM), Volume 18, Issue 7 .Ver. IV , PP 15-21, e-ISSN: 2278-487X, p-ISSN: 2319-7668.
10. Reddy Hariharanath, Reddy S. Raghunatha (2014),” Consumer Perception Towards Retail Industry: A Study”, International Journal on Customer Relations, volume 2 ,Issue1
11. Vashishth Gaurav , Dr Nishi Tripathi (july 2016),” A study of Customer perception towards the exclusive showroom and retail outlets”, IOSR Journal of Business and Management (IOSR-JBM), Volume 18, Issue 7 .Ver. III, PP 40-45,e-ISSN: 2278-487X, p-ISSN: 2319-7668

---

## **Review Article-Emission of Greenhouse Gases from Agriculture and Its Mitigation**

**Sunil kumar.V \***

**Padmaja D\*\***

**Rajini \*\*\***

**Sudhakar K.\*\*\*\***

### **Abstract**

Agriculture is an important sector of the economy in India, contributing about 20% of national gross domestic product, and providing a livelihood for nearly two-thirds of the population. Agriculture is a major source of greenhouse gas (GHG) emissions globally. The growing global population is putting pressure on agricultural production systems that aim to secure food production while minimising GHG emissions. Global warming, caused by the increase in concentration of greenhouse gases (GHGs) in the atmosphere and it has emerged as the most important environmental issue all over the world. These GHGs viz. carbon dioxide (CO<sub>2</sub>), methane (CH<sub>4</sub>) and nitrous oxide (N<sub>2</sub>O) trap the outgoing infrared radiations from the earth's surface and thus raise the atmospheric temperature, ozone depletion, Increased melting of snow and ice, Sea level rise, Stronger storms, and intermittent rains and Ozone layer depletion. The mitigation of GHGs emission from agriculture can be achieved by sequestering C in soil and reducing the emissions of methane and nitrous oxide from soil through changes in land-use management and enhancing input-use efficiency. Crop diversification, mixed cropping system, zero tillage, integrated nutrient management, application of bio fertilizers, site specific nutrient management. The changes in crop genetics by development of high nitrogen use efficiency (high-NUE) rice cultivars and direct seeding. Management of irrigation by AWD, micro irrigation, fertilizer use, and soils can reduce emission of both nitrous oxide and methane. Such options are important not only for global warming mitigation but also for improving soil fertility. In addition, the GHGs emissions can be reduced by the substitution of fossil fuels for energy production by the agricultural feedstocks (e.g. crop residues, dung, and dedicated energy crops) and solar energy.

### **Introduction**

Agriculture is an important sector of the economy in India, contributing about 20% of national gross domestic product, and providing a livelihood for nearly two-thirds of the population (Pathak et al., 2014). Equally important is the contribution of agriculture to national food security. India achieved self-sufficiency in food production after the Green Revolution (GR), but retaining this success has been challenging due to the increasing scarcity of resources, including labour, water, energy, and rising costs of production

---

\* Department of Chemistry, Osmania University, Hyderabad, Telangana-500007, India

\*\*Scientist, Regional Agricultural Research Station, Polasa, Jagtial

\*\*\* Department of Genetics and Plant Breeding, Rajendranagar, Hyderabad

\*\*\*\* A1 Green Pharma solutions, Miyapur, Hyderabad-500049

(Saharawat et al., 2010). Increased use of production inputs, such as mineral fertilizer, has made Indian agriculture more greenhouse gas (GHG)-intensive. Agricultural production is a major emitter of GHGs, currently accounting for 18% of total GHG emissions in India. The production of rice in South Asia, including India, has increased markedly with the introduction and widespread adoption of modern crop production technologies such as early maturing and N responsive semi-dwarf cultivars; high use of inorganic fertilizers, especially N fertilizers, and pesticides; and the expansion of irrigation facilities. The chemical environment of reduced soil and the extremely limited O<sub>2</sub> supply in the soil-flood water system has a large influence on carbon (C) and nitrogen (N) dynamics of irrigated rice systems.

Carbon dioxide (CO<sub>2</sub>), methane (CH<sub>4</sub>) and nitrous oxide (N<sub>2</sub>O) are the key greenhouse gases (GHG) that contribute towards the global warming at 60, 15 and 5%, respectively (Watson et al., 1996). Concentrations of these gases in the atmosphere are increasing at 0.4, 3.0 and 0.22% per year, respectively (Battle et al., 1996). Apart from causing global warming N<sub>2</sub>O is also responsible for the destruction of the stratospheric ozone (Li et al., 2004). Quantification of GHG emissions is needed for global modelling studies in the context of ecosystem modification and climate change (Li et al., 1997). Global and regional estimates of GHG emission from rice paddy fields vary greatly with the assumptions made on the importance of different factors affecting the emissions.

Carbon dioxide (CO<sub>2</sub>) emissions were by far the largest contributor to GHG emissions and global warming potential (GWP) in SSA natural terrestrial systems. The increasing trend in N application rates is expected to cause a 2-fold increase in agricultural N<sub>2</sub>O emissions in the continent by 2050 (Hickman et al., 2011). In the case of CH<sub>4</sub> emissions, there are important differences between ecosystems. Tropical humid forest, wetlands, rice paddy fields, and termite mounds are likely sources of CH<sub>4</sub>, while seasonally dry forests and savannahs are typically CH<sub>4</sub> sinks (Valentini et al., 2014).

#### **a. Emission of GHGs from Agriculture**

Agriculture contributes to greenhouse effect primarily through the emission and consumption of GHGs such as CH<sub>4</sub>, N<sub>2</sub>O and CO<sub>2</sub>. CH<sub>4</sub> is produced in soil during microbial decomposition of organic matter under anaerobic conditions. Rice fields submerged under water are the potential source of CH<sub>4</sub> production. Continuous submergence, higher organic C content and use of organic manure in puddled soil enhance CH<sub>4</sub> emission. Burning of crop residues also contributes to the global methane budget. The enteric fermentation in ruminants is another major source of CH<sub>4</sub> emission. Highest GHG emissions from food production are from rice and ruminant products (Sylvia et al., 2017).

Nitrous oxide is produced naturally in soils through the processes of nitrification and denitrification. Nitrification is the aerobic microbial oxidation of ammonium to nitrate, and denitrification is the anaerobic microbial reduction of nitrate to nitrogen gas (N<sub>2</sub>). Nitrous oxide is a gaseous intermediate in the reaction sequence of denitrification and a by-product of nitrification that leaks from microbial cells into the soil and ultimately into the atmosphere. One of the main controlling factors in this reaction is the availability of inorganic N in soil through human-induced net N additions to soils (Pathak et al., 2014).

The main source of carbon dioxide production in agriculture is the soil management practices such as tillage which triggers the emission of this gas through biological decomposition of soil organic matter. Tillage breaks the soil aggregates, increases the oxygen supply and exposes the surface area of organic material promoting their



decomposition. Use of fuel for various agricultural operations and burning of crop residues are other sources of carbon dioxide emission. An off-site source is the production of carbon dioxide during manufacturing of farm implements, fertilizers and pesticides (Pathak et al., 2014).

### **Global Green House Gas Emissions**

At the global scale, the key greenhouse gases emitted by human activities are:

- **Carbon dioxide (CO<sub>2</sub>):** Fossil fuel use is the primary source of CO<sub>2</sub>. CO<sub>2</sub> can also be emitted from deforestation, land clearing for agriculture, and degradation of soils. Likewise, land can also remove CO<sub>2</sub> from the atmosphere through reforestation, improvement of soils, and other activities.
- **Methane (CH<sub>4</sub>):** Agricultural activities, waste management, rice fields, energy use, and biomass burning all contribute to CH<sub>4</sub> emissions.
- **Nitrous oxide (N<sub>2</sub>O):** Agricultural activities, such as fertilizer use, are the primary source of N<sub>2</sub>O emissions. Fossil fuel combustion also generates N<sub>2</sub>O. Additionally, biomass burning produces N<sub>2</sub>O
- **Fluorinated gases (F-gases):** Industrial processes, refrigeration, and the use of a variety of consumer products contribute to emissions of F-gases, which include hydrofluorocarbons (HFCs), perfluorocarbons (PFCs), and sulfur hexafluoride (SF<sub>6</sub>).

#### **b. Mitigation of methane and nitrous oxide emission**

To reduce CH<sub>4</sub> emissions, many researchers have suggested the intermittent flooding approach. Bhatia et al. (2012b) have shown that by shifting water management from the current practice to intermittent flooding in all the irrigated rice area of the country, the national CH<sub>4</sub> flux from irrigated rice fields could be reduced by 40% (Pathak et al. 2013). Direct-seeding of rice (DSR) and system of rice intensification (SRI) could be the potential options for reducing methane emission. Methane is emitted from soil when it is continuously submerged under water in the case of conventional puddled transplanted rice. The DSR and SRI crops do not require continuous soil submergence, and therefore reduce methane emission when rice is grown as an aerobic crop. Since DSR and SRI reduce methane emissions drastically low compared to the conventional puddle transplanted rice (Pathak et al. 2015)

To reduce nitrous oxide emission, the most efficient management practices are site-specific nutrient management and use of nitrification inhibitors such as coated calcium carbide and dicyandiamide (Pathak et al., 2014). There are some plant-derived organics such as neem oil, neem cake and karanja seed extract which can also act as nitrification inhibitors (Pathak et al. (2010). The demand-driven N use using a leaf colour chart (LCC) could reduce nitrous oxide emission and GWP by about 11-14% (Bhatia et al. 2012b, Jain et al. 2013). The major causes for GHG emissions are mainly due to lack of seasonal rains, release of CO<sub>2</sub> into atmosphere, continuous flooding in rice, and use of synthetic fertilizers. These causes can be overcome by following alternate wetting and drying, aerobic rice technology, direct dry seeding (Pathak et al., 2014)

#### **c. Sequestration of carbon in agricultural soils**

The mitigation of CO<sub>2</sub> emission from agriculture could also be achieved by increasing C sequestration in soil, which implies the storage of C as soil organic matter (Lal 2004, Pathak et al. 2011). The use of organic manure and compost enhances the SOC pool more than the application of same amount of nutrients as inorganic fertilizers. The longterm

manure application increases the SOC pool, and the effects may persist for a century. The increased SOC not only mitigates CO<sub>2</sub> emission but also enhances soil productivity.

#### **d. Conservation agriculture**

Conservation agriculture with adoption of resource- conserving technologies such as zero- or Minimum tillage with direct seeding, permanent or semipermanent residue cover, and crop rotations have potential to enhance the use efficiency of natural resources such as water, air, fossil fuel and soil. These technologies can improve the sustainability of agriculture by conserving the resource base with higher input-use efficiency and also mitigating GHGs emissions was reported by Pathak *et al.* (2014).

#### **e. Genetic enhancement of crops**

A large increase in food production has been achieved through development of new varieties and hybrids through genetic selection, adoption of improved breeding techniques, and genetic engineering and modification technology by Pathak *et al.* (2014). Identify the genotypes with increase productivity, as well as drought and pest resistance and improve other traits such as increased efficiency of input uptake or even producing inputs within the plant and enhancement of beneficial nutrients in soils

- Gui Chen *et al.* (2015) developed several high nitrogen use efficiency (high-NUE) rice cultivars to meet the increased food demand and urgent environmental concerns, but the effect of these cultivars on reducing N losses from paddy fields is not well documented. Ammonia (NH<sub>3</sub>) volatilization, N<sub>2</sub>O emission, N leaching and runoff losses were monitored during the entire rice growing season within a rice–wheat rotation. It was concluded that improving N uptake rate of high-NUE cultivars in the early stages of growth would be most effective in decreasing N losses and that the main part of N fertilizer applications should be later in the growing season than is currently practiced in the region.

Yuefang *et al.*(2015) conducted a 3-year field experiment in a wheat–rice cropping system in a silt clay loam soil and investigated the effects of the type of tillage employed during the wheat-growing season no-tillage (NT), reduced tillage (RT) or conventional tillage (CT)) on the emissions of N<sub>2</sub>O and CH<sub>4</sub> using the static chamber method over three annual rotation cycles. The adoption of an NT system during the wheat-growing season significantly increased CH<sub>4</sub> emissions during both the wheat-growing season and the following rice-growing season. The annual N<sub>2</sub>O emissions from the NT and CT treatments were similar to each other and significantly higher than those from the RT treatment; the annual CH<sub>4</sub> emissions were significantly higher from the NT than the CT and RT systems. Soils act as sources and sinks for greenhouse gases (GHG) such as carbon dioxide (CO<sub>2</sub>), methane (CH<sub>4</sub>), and nitrous oxide (N<sub>2</sub>O). Soil emission studies involves the most important land-cover types and climate zones and introduces important measuring systems for soil emissions. It addresses current shortcomings and the obvious bias towards northern hemispheric data. Conservative average of 300 mg CO<sub>2</sub>e m<sup>-2</sup> h<sup>-1</sup>, leads to global annual net soil emissions of ≥350 Pg CO<sub>2</sub>e. This corresponds to roughly 21% of the global soil C and N pools Cornelius *et al.* (2016).

Tongwane *et al.* (2016) calculated GHG emissions and compared among different crop production and management practices. It is estimated that production of field crops resulted in a total of 5.2 million tones of CO<sub>2</sub> equivalent(CO<sub>2</sub>-eq) emissions in South Africa in 2012. Application of synthetic fertilizer contributes the highest emissions with 57% of national total crop CO<sub>2</sub>-eq emissions, followed by addition of lime (30%) and crop

residues retained in the field(13%). Production of cereal crops accounts for 68% of national total field crops' GHG emissions followed by other field crops(14%), legumes and oilseeds (11%) and vegetables(7%). Cultivations of maize, wheat and sugarcane result in highest commodity emissions. These results show that mitigation plans of emissions from field crops in SouthAfrica need to focus more on sustainable improvement of soil fertility, optimum application of synthetic N fertilizer and crop residues.

The application rate of nitrogen fertilizer was believed to dramatically influence greenhouse gas (GHG) emissions from paddy fields. Thus, providing a suitable nitrogen fertilization rate to ensure rice yields, reducing GHG emissions and exploring emission behavior are important issues for field management. The Global Warming Potential(GWP) and rice yields increased with an increasing application rate of nitrogen fertilizer. Emission peaks of CH<sub>4</sub> mainly appeared at the vegetative phase, and emission peaks of CO<sub>2</sub>, and N<sub>2</sub>O mainly appeared at reproductive phase of rice growth. The CO<sub>2</sub> flux was significantly correlated with soil temperature, while the CH<sub>4</sub> flux was influenced by logging water remaining period and N<sub>2</sub>O flux was significantly associated with nitrogen application rates (Yiming Zhong (2016)).

Traore *et al.* (2017) measured methane (CH<sub>4</sub>) emissions from Chinese paddy soil (Zhejiang province) over the rice growing seasons. Different fertilizers (organic and chemical) were applied, emissions of methane were high during two periods (05 days after peak tillering and 07 days after heading flowering stage) and significant effects of fertilizers were observed. Methanogenic activities in soils treated with organic manure were obviously higher than those with chemical fertilizers. Among the organic manure fields the maximum methane emission from green manure, biogas residue and beef manure treatment were 52, 20 and 19 times, respectively of that given by control, and among chemical fertilizers it was NH<sub>4</sub>HCO<sub>3</sub> > CO(NH<sub>2</sub>)<sub>2</sub> > (NH<sub>4</sub>)<sub>2</sub>SO<sub>4</sub> > NH<sub>4</sub>Cl > NaNO<sub>3</sub> with 2.4, 2, 1.5, 1.3, and 0.2 times, respectively of that from control.

Sylvia *et al.* (2017) concluded that agriculture is a major source of greenhouse gas (GHG) emissions globally. The GHG emissions associated with the production of major food commodities in India are calculated using the Cool Farm Tool. GHG emissions, based on farm management for major crops (including cereals like wheat and rice, pulses, potatoes, fruits and vegetables) and livestock-based products (milk, eggs, chicken and mutton meat), are quantified and compared. Livestock and rice production were found to be the main sources of GHG emissions in Indian agriculture with a country average of 5.65 kg CO<sub>2</sub>eq kg<sup>-1</sup> rice, 45.54 kg CO<sub>2</sub>eq kg<sup>-1</sup> mutton meat and 2.4 kg CO<sub>2</sub>eq kg<sup>-1</sup> milk. Production of cereals (except rice), fruits and vegetables in India emits comparatively less GHGs with <1 kg CO<sub>2</sub>eq kg<sup>-1</sup> product.

Le Qi *et al.* (2018) investigated the greenhouse gas emission under different application of biochar in the conditions of continuous flooding and water-saving irrigation in paddy fields, whereas, plant and soil carbon sequestration were considered in the calculation of net greenhouse gas emissions. Compared with the water-saving irrigation, the continuous flooding irrigation significantly increased the CH<sub>4</sub> in the control (CK) and chemical fertilizer treatments (NPK).The CO<sub>2</sub> emissions increased in each treatment of the water-saving irrigation condition, especially in the chemical fertilizer treatments. Biochar application in soils cut down the soil N<sub>2</sub>O emission more significantly than NPKFW in the water-saving irrigation condition while the effect of biochar increased under the continuous flooding irrigation condition. Co<sub>2</sub> and fertilizers can be reduced through

substituting biogas for firewood for cooking and kerosene and bio-fertilizers for chemical fertilizers (Pathak et al. 2009a).

### **Conclusion**

Greenhouse gas emissions can be reduced by practicing some methods by several reports by several high nitrogen use efficiency (high-NUE) rice cultivars have been developed which reduces volatilization losses and also reduces N<sub>2</sub>O emissions. Although GHGs emissions can be released into the atmosphere, especially CO<sub>2</sub>, can be removed from the atmosphere by sequestering carbon in biomass, organic matter, and soils. CH<sub>4</sub> emissions from paddy fields can be reduced by adopting alternate wetting and drying and aerobic rice technology. GHG emission reduction strategies include decreased land clearing for agriculture, extended rotations for forest stands, afforestation and reforestation, and conservation management strategies for agriculture and forestry. Addressing GHG emissions and sinks from land use, land-use change, and forest activities are critical scientific and policy questions.

### **References**

- Battle, M., Bender, M., Sowers, T., Tans, P. P., Butler, J. H., Elkins, J.W., Ellis, J. T., Conway, T., Zhang, N., Lang, P., and Clarke, A. D.: Atmospheric gas concentrations over the past century measured in air from firn at the south pole, *Nature*, 383, 231–235, 1996.
- Bhatia A, Aggarwal PK, Jain N and Pathak H (2012) Greenhouse gas emission from rice and wheat-growing areas in India: Spatial analysis and upscaling. *Greenhouse Gas Sci Technol* 2 115-125
- Environmental Science and Technology*. Vol. 11(1), pp. 89-93.
- Gui Chen., Ying Chen., Guohua Zhao., Wangda Cheng., Shiwei Guo., Hailin Zhang and Weiming Shi. 2015. Do high nitrogen use efficiency rice cultivars reduce nitrogen losses from paddy fields. *Agriculture, Ecosystems & Environment*. 209(1)26-33.
- Hickman, J. E., Havlikova, M., Kroeze, C., and Palm, C. A.: Current and future nitrous oxide emissions from African agriculture, *Curr. Opin. Environ. Sustain.*, 3, 370–378, 2011.
- Jain N, Dubey R, Dubey D S, Singh J, Khanna M, Pathak H and Bhatia A (2013) Mitigation of greenhouse gas emission with system of rice intensification in the Indo-Gangetic Plains Paddy Water Environ
- Le Qi., Hai Dong Niu., Peng Zhou., Rui Jie Jia. and Ming Gao. 2018. Effects of Biochar on the Net Greenhouse Gas Emissions under Continuous Flooding and Water-Saving Irrigation Conditions in Paddy Soils. *Sustainability*.
- Li, C., Frohling, S., Crocker, G. J., Grace, P. R., Klir, J., Korcdhens, M., and Poulton, P. R. Simulating trends in soil organic carbon in long-term experiments using the DNDC model, *Geoderma*, 81, 45–60, 1997.
- methane emission from paddy field of Zhejiang, China. *African Journal of*
- Oertel, C., Matschullat, J., Zurba, K., Zimmermann, F. and Erasmí, S. 2016. Greenhouse gas emissions from soils. *Chemie der Erde - Geochemistry*. 76(9)327-352.
- Pathak H, Adhya T K, Sikka A K and Islam A (2015) Water and climate change. In: State of Indian Agriculture: Water (Pathak H, Bhatt B P and Gupta S K, eds) pp. xx + 103 National Academy of Agricultural Sciences, New Delhi



- Pathak H, Bhatia A and Jain N (2014) Greenhouse Gas Emission from Indian Agriculture: Trends, Mitigation and Policy Needs. Indian Agricultural Research Institute, New Delhi book.
- Pathak H, Byjesh K, Chakrabarti B and Aggarwal P K (2011a) Potential and cost of carbon sequestration in Indian agriculture: Estimates from long-term field experiments Field Crops Res 120 102-111
- Pathak H, Jain N, Bhatia A, Patel J and Aggarwal P K (2010) Carbon footprints of Indian food items Agric Ecosys Environ 139 66-73
- Pathak, H., Bhatia, A., Shiv Prasad, Singh, S., Kumar, S., Jain, M.C., Kumar, U., 2002. Emission of nitrous oxide from soil in rice-wheat systems of Indo-Gangetic Plains of India. J. Environ. Monitor. Assessm. 77 (2), 163-178.
- R.K. Rajesh Krishnan, A. Lakshmanan, K. Ajith and P. Shajeeshjan 2017. Sobering Rice Production from Conventional to Climate Smart .Int.J.Curr.Microbiol.App.Sci 6(9): 2804-2813
- Rodhe, A. L.: A comparison of the contribution of various gases to the greenhouse effect, Science, 248, 1217-1219, 1990.
- Sylvia H.Vetter., Tek B.Sapkota., Jon Hillier., Clare M.Stirling., Jennie I.Macdiarmid., Lukasz Aleksandrowicz., Rosemary Green., Edward J.M.Joy., Alan D.Dangour. and Pete Smith. Greenhouse gas emissions from agricultural food production to supply Indian diets: Implications for climate change mitigation. *Agriculture, Ecosystems & Environment*. Vol. 237, pp. 234-241.
- Tongwane, M., Mdlambuzi, T., Moeletsi, M., Tsubo, M., Mliswa, V. and Grootboom, L. 2016. Greenhouse gas emissions from different crop production and management practices in South Africa. *Environmental Development*. 19(2016)23-35.
- Traore, B., Samake, F., Amadoun babana. And Hang, M. 2017. Effects of different fertilizers on
- Valentini, R., Arneeth, A., Bombelli, A., Castaldi, S., Cazzolla Gatti, R., Chevallier, F., Ciais, P., Grieco, E., Hartmann, J., Henry, M., Houghton, R. A., Jung, M., Kutsch, W. L., Malhi, Y., Mayorga, E., Merbold, L., Murray-Tortarolo, G., Papale, D., Peylin, P., Poulter, B., Raymond, P. A., Santini, M., Sitch, S., Vaglio Laurin, G., van der Werf, G. R., Williams, C. A., and Scholes, R. J.: A full greenhouse gases budget of Africa: synthesis, uncertainties, and vulnerabilities, *Biogeosciences*, 11, 381-407, doi:10.5194/bg- 11-381-2014.
- Watson, R. T., Zinyowera, M. C., Moss, R. H., and Dokken, D. J.: Climate Change 1995, impacts, adaptations and mitigation of climate change: Scientific-technical analyses, Intergovernmental Panel on Climate Change, Cambridge University Press, USA, 879, 1996.
- Yiming Zhong., Xia openg., WangJingping., YangXing Zhao., Xin yi Ye. 2016. Exploring a suitable nitrogen fertilizer rate to reduce greenhouse gas emissions and ensure rice yields in paddy fields. *Science of the Total Environment*. Vol. 526, pp. 420-426.
- Yuefang Zhang., Jing Sheng., Zichen Wang., Liugen Chen., Jianchu Zheng. 2015. Nitrous oxide and methane emissions from a Chinese wheat-rice cropping system under different tillage practices during the wheat-growing season. *Soil and Tillage Research*. Vol. 146, pp. 261-269.



## **Client Preference of Supermarket Store For Different Product**

**Rashmi\***

### **Abstract**

This Paper Researches the Client Preference of supermarket store for different products. The study was to difficulties related with the development of Supermarket store and to comprehend the development of the Market store. Fluctuating client inclinations and focused powers are putting more weight on showcasing and are requesting predominant deals and advertising system what's more, strategic execution.

### **Introduction**

The India Retail Industry is the biggest among every one of the ventures, representing more than 10 for each penny of the nation GDP and around 8 for each penny of the business. The Retail Industry in India has approached as a standout amongst the most unique and quick paced enterprises with a few players entering the market. In any case, every one of them have not yet tasted achievement on account of the overwhelming starting ventures that are required to earn back the original investment with different organizations and rival them. The India Retail Industry is progressively creeping its way towards turning into the following blast industry.

The aggregate idea and thought of shopping has experienced a consideration attracting change terms of arrangement and shopper purchasing conduct, introducing an upheaval in shopping in India.

Current retailing has gone into the Retail advertise in India as is seen as clamoring strip malls, multi-storied shopping centers and the enormous edifices that offer shopping, stimulation and nourishment all under one rooftop. An expansive youthful working populace with middle age of 24 years, atomic families in urban territories, alongside expanding workingwomen populace and developing open doors in the administrations segment will be the key factors in the development of the sorted out Retail part in India. The development design in sorted out retailing and in the utilization made by the Indian populace will take after a rising diagram causing the more current agents to enter the India Retail Industry.

Buying intensity of Indian urban buyer is developing and marked stock in classes like Apparels, Cosmetics, Shoes, Watches, Beverages, Food and even Jewelry, are gradually getting to be way of life items that are generally acknowledged by the urban Indian buyer. Indian retailers need to preferred standpoint of this development and intending to develop, enhance and acquaint new organizations have with give careful consideration to the brand building process. The accentuation here is on retail as a brand instead of retailers offering brands. The concentration ought to be on marking the retail business itself. In their arrangement to confront wild aggressive weight, Indian retailers must come to perceive the benefit of building their own stores as brands to strengthen their advertising situating, to impart quality and incentive for cash.

The retailing position in India is portrayed by these sort of stores.

---

\* Research Scholar, Department of Management, DCRUST University, Murthal, Haryana

**1. Shopping centers** -The biggest type of composed retailing today. Found for the most part in metro urban areas, in closeness to urban edges. Reaches from 60,000 sq ft to 7,00,000 sq ft or more. They loan a perfect shopping background with an amalgamation of item, administration and excitement, all under a regular rooftop. Cases incorporate Shoppers Stop, Piramyd, and Pantaloon.

**2. Rebate Stores** -As the name proposes, markdown stores or plant outlets, offer rebates on the MRP through offering in mass achieving economies of scale or overabundance stock left finished at the season. The item class can go from an assortment of transient/durable products.

**3. Retail establishments** -Huge stores extending from 20000-50000 sq. ft, taking into account an assortment of buyer needs. Additionally ordered into restricted offices, for example, garments, toys, home, foodstuffs, and so on. Departmental Stores are relied upon to assume control over the attire business from selective brand showrooms. Among these, the greatest achievement is K Raheja's Shoppers Stop, which began in Mumbai and now has in excess of seven huge stores (more than 30,000 sq. ft) crosswise over India and even has its own in store mark for garments called Stop.

**4. Hyper bazaars/Supermarkets** -Substantial self-benefit outlets, taking into account changed customer needs are named as Supermarkets. These are situated in or close private high roads. These stores today add to 30% of all sustenance and basic supply sorted out retail deals. Stores can additionally be arranged in to little store ordinarily 1,000 sq ft to 2,000 sq ft and extensive grocery stores running from of 3,500 sq ft to 5,000 sq ft. having a solid spotlight on nourishment and staple and individual deals.

### **Review of Literature**

Jayawardhena (2011) in an examination led in Central India, tried a reasonable model of the impacts of client and administration introduction practices of individual retail workers on singular clients' view of administration experience quality , benefit quality , esteem, fulfillment, and social goals (BI).The test was clients of a market in focal India, and they finished polls following shopping center capture. To test the theories, auxiliary condition displaying was utilized. They found that administration and client introduction practices are emphatically identified.SEQ is emphatically identified with SQ and consumer loyalty; SQ is decidedly identified with esteem recognitions and consumer loyalty; and consumer loyalty is emphatically identified with retail clients' BI. Anyway the investigation found that esteem isn't identified with consumer loyalty.

Ghosh, Tripathi and Kumar (2010) in their investigation directed in Indian setting, endeavored to deliver issues identified with store properties and their importance in the store organize determination. Eleven factors (store properties) had been recognized in view of hypothesis and judgment. Factor investigation had yielded three variables: Convenience and Merchandise Mix, Store Atmospheric, furthermore, Services. The variables recognized and suggestions made would be useful to retailers in outlining their outlets with store characteristics that would meet the desires for customers furthermore, in this way inspire them towards store support choices.

Huddleston et al. (2009) in their examination directed on US family units, investigated client discernments identified with fulfillment with traditional markets when contrasted with strength supermarkets. Their investigation analyzed store traits of item arrangement, value, quality and administration keeping in mind the end goal to figure out which properties had the best effect on store fulfillment for each store arrange. The outcomes

demonstrated that impression of fulfillment were higher among claim to fame market clients contrasted with traditional supermarket clients. For both store organizes, the examination found that store cost, item collection, administration and quality emphatically affected fulfillment.

Kaul (2007) in an investigation directed in the city of Bangalore analyzed the pertinence of Retail Administration Quality Scale (RSQS) created in the US in India. RSQS has five measurements and six sub-measurements and has been discovered proper in an assortment of settings — crosswise over various nations, for example, South Africa and Singapore and over an assortment of store composes, for example, General stores, Department stores, and Hyper stores. The five measurements — Physical 20 Perspectives, Reliability, Personal Interaction, Problem Solving, and Policy are accepted to catch particular however related parts of retail benefit. Every one of the initial three measurements has two sub-measurements. These six sub-measurements, likewise called the main request factors, are named as Appearance, Convenience, Promises, Doing it-Right, Inspiring Confidence, and Politeness/Helpfulness. Information utilizing an overview poll from 144 grown-up customers at huge arrangement attire stores demonstrated that the RSQS measurements and sub-measurements were most certainly not obviously identifiable. The examination found that the measurement of 'Physical Appearance' is the main one that is generally clear. Every other measurement was observed to be not well characterized. The measurement of 'Critical thinking' was observed to be dim and all the rest of the measurements of RSQS included one factor. The examination presumed that RSQS has constrained symptomatic application and is wrong for application in Indian retail.

### **Research Design**

Research configuration is orderly system for accumulation and investigation of information. It is a blue print that aides the examination to be finished. The present research work is finished with the unmistakable inquire about outline strategy. Distinct research has been utilized as a part of this examination to get data about the different difficulties and openings rising in web based managing an account. Different data gathered are broke down and organized completely. Finally the discoveries of the investigation are dealt with to exhibit the consequence of the examination in clear terms and breaking down of the information is all the more effortlessly done.

### **Data Collection Methods**

- 1) Primary Data – Primary Data are those which are gathered a new and out of the blue. In this investigation, has been gathered through individual contact.
- 2) Secondary Data – Secondary Data are those which have just been gathered by another person. In this investigation, auxiliary source information has been gathered from Articles, diaries and Websites investigate papers.

### **How often do you shop?**

1	Daily	6 %
2	Weekly	40 %
3	Fortnightly	23 %
4	Monthly	33 %

### **Interpretation**

6.06% of them buy day by day, 40% of them buy week after week, 23.3% of them buy month to month and there are no respondents who buy fortnightly. This unmistakably demonstrates recurrence of procurement by the buyers is high.

---

**How do you make your purchases in supermarket stores?**

S. No	Particulars	Percentage
1	Only the products in your shopping list	36 %
2	Randomly pick up the things that you need	23 %
3	Purchase the things that are more visible	20 %
4	Purchase the things on which there is max discount	16 %
5	Shopping assistance recommendation	3 %

**Interpretation**

The reaction given by respondents demonstrates that 3.33% of the respondents want to purchase by the shopping help recommendation.16.66% buy the things on which there is max discount.20% buy the things that are more visible.23.33% haphazardly get the things that they need.36.66% of the respondents make the buys just the items in their shopping list.

**Bibliography**

- 1) Ghosh, P., Tripathi, V., and Kumar, A. (2010). Customer expectations of store attributes: A study of organized retail outlets in India. *Journal of Retail*
- 2) Huddleston, P., Whipple, J., Mattick, R. N., and Lee, S. J. (2009). Customer satisfaction in food retailing: comparing specialty and conventional grocery stores. *International Journal of Retail and Distribution Management*, 37(1), 63-80.
- 3) Jayawardhena, C. (2011). Effects of retail employees' behaviours on customers' service evaluation. *International Journal of Retail & Distribution Management*, 39 (3), 203-217.
- 4) Kaul, S. (2007). Measuring retail service quality: Examining applicability of international research perspectives in India. *Viklapa*, 32 (1).

**Internet**

- 1) WWW.RETAILINDIA.COM
- 2) WWW.GOOGLE.COM

---

## **“Simulink Modelling Of PVS Array with Different Type Irradiation Input”**

**A Kishore kumar\***

**Asst. Prof. Pradeep Singh Chauhan\*\***

### **Abstract**

The solar radiation intensity is the primary parameter that affects the PV panel outcomes. However, the solar radiation has a group of wavelengths, and each one of them can influence the solar cell in a different way from other wavelengths. The spectrum wavelengths are related to the energy's frequencies. The present study aimed to find the wavelength/color that causes the highest PV panel outcome and the best electricity conversion. Seven colored filters were added once solo and once again combined but except one. The study results reveal that the PV panel output for the natural spectrum is the highest compared to the other colored light. This is almost certainly due to the loss of light intensity inherent to the tint of the color filters. The blue screen employment resulted in lowest output power compared to the other colored filter. The study results proved that the visible spectrum of the solar radiation affects the solar panel outcomes.

**Keyword: Photovoltaic, Maximum Power Point Tracker, Solar Photovoltaic, and Maximum Power Point**

### **I.Introduction**

Solar energy is one the most effective, less expensive, harmless and less environmental pollution effect of renewable energy sources. The utilization of solar energy can be categorized in two ways: solar heating/cooling and solar electricity. This energy can be converted into electrical energy through implementation of photovoltaic array [1]. Recently, Photovoltaic (PV) systems application is well recognized and widely used in electric power technologies. Many applications regarding to this technology have been developed such as solar power generation, solar vehicle construction, battery charging, water pumping, and satellite power system and so on. Unfortunately, PV system has its own drawbacks, which are mainly due to high fabrication cost and low energy conversion. It is caused by their nonlinear, isolation level and temperature-dependent of Current-voltage (I-V) and Power Voltage (P-V) characteristics. To tackle these problems, three essential approaches have been developed. They are: 1) improving manufacturing process of solar array. 2) Controlling the isolation input to PV array; the input of solar energy is maximized using sun-tracking solar collector. 3) Utilization of output solar arrays electric power [3]. The nonlinear variations of output voltage and current that depends on solar-radiation levels, operating temperature, and load current to cause in low electrical efficiency. To solve these problems, by utilizing approach, the maximum power point of the PV system (at given condition), is tracked using offline or online algorithms where the system operating point is forced toward optimal condition. To obtain the maximum power from PV array, a Maximum Power Point Tracker (MPPT) is applied. Thus, there are some

---

\*Student of MTECH Power system and Power Electronics, Department Electrical and Electronics Engg.

\*\*Asst.Prof. Department Electrical and Electronics Engineering.O.P. JINDAL UNIVERSITY PUNJIPATHRA RAIGARH (C.G.)



techniques used to track the maximum power point, which is known as “look-up table” methods; “Perturbation and Observation (P%O)”, “Modified P & O”& “Estimate perturb-perturb” methods [1][2].

The growing need for energy in the whole world has caused increasing global warming and air pollution dramatically in addition to the depletion of fossil fuels for power generation [1]. The clean solar energy use and available in most parts of the world considered the optimal solution to the problems caused by excessive burning of fossil fuels for power generation [2]. The conversion of solar energy into electricity has been a priority; this issue has become a matter of broad prospects in both space and terrestrial applications [3]. Photovoltaic cells as solar energy applications are used to convert the solar energy directly into electricity by pairs of semiconductor interact with the effect of light [4]. The limited efficiency of the photovoltaic is the hindering reason for the widespread use of solar cells. The primary cause of the photovoltaic cell low efficiency is that it uses a small part of the energy in the solar spectrum [5]. The solar radiation falling to the ground is divided from the wavelength to three wavelengths with different energy content [6]:

- Ultraviolet (UV) (less than 400 nm), with an energy content of 5-10% from the total energy.
- Visible light (VL) (400-700 nm); energy content of 40% from the total energy.
- Infrared (IR) (above 700 nm); energy content of 50% from the total energy.

## II. Photovoltaic Array

PV cells are made of semiconductor materials, such as silicon. When light energy strikes the solar cell, electrons are knocked loose from the atoms in the semiconductor material. If electrical conductors are attached to the positive and negative sides, forming an electrical circuit, the electrons can be captured in the form of an electric current - that is, electricity. This electricity can then be used to power a load. Due to the low voltage generated in a PV cell (around 0.5V), several PV cells are connected in series (for high voltage) and in parallel (for high current) to form a PV module for desired output, as shown in Figure 2 [2-3]. The power that one module can produce is not sufficient to meet the requirements of home or business. Most PV arrays use an inverter to convert the DC power into alternating current that can power the motors, loads, lights etc. The modules in a PV array are usually first connected in series to obtain the desired voltages; the individual modules are then connected in parallel to allow the system to produce more current [4].

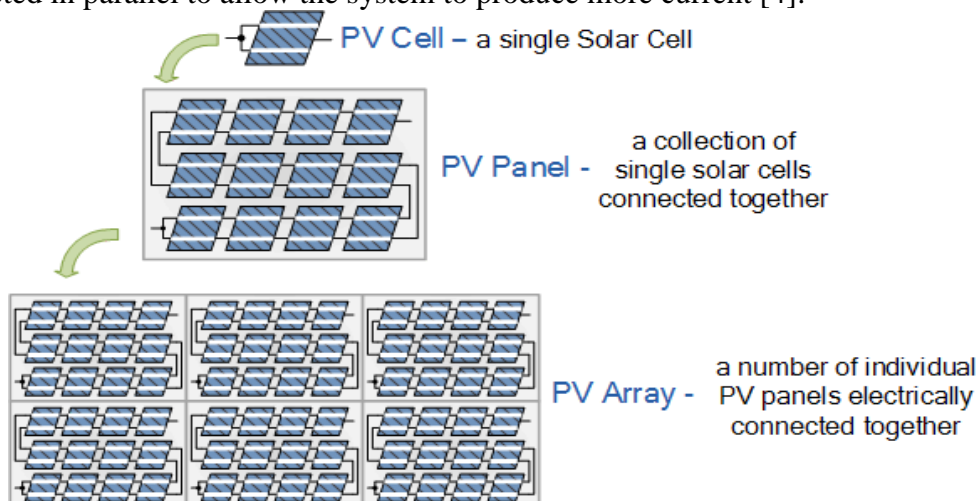

Figure 2: Photovoltaic system



### Efficiency of PV Cell

The efficiency of a PV cell is defined as the ratio of peak power to input solar power.

$$\eta = \frac{V_{mp} I_{mp}}{I \left( \frac{KW}{m^2} \right) \cdot A \left( m^2 \right)}$$

$$\eta = \frac{\text{Power Tracked}}{V_{mpp} I_{mpp}}$$

where,  $V_{mp}$  is the voltage at peak power,  $I_{mp}$  is the current at peak power, as shown in Figure 3,  $I$  is the solar intensity per square metre,  $A$  is the area on which solar radiation fall. The efficiency will be maximum if we track the maximum power from the PV system at different environmental condition such as solar irradiance and temperature by using different methods for maximum power point tracking.

### III.Effect of Irradiance & Temperatureeffect on VI Characteristics

Two important factors that have to be taken into account are the irradiation and the temperature. They strongly affect the characteristics of solar modules. As a result, the MPP varies during the day and that is the main reason why the MPP must constantly be tracked and ensure that the maximum available power is obtained from the panel. The effect of the irradiance on the voltage-current (V-I) and voltage-power(V-P) characteristics is depicted in Figure 4, where the curves are shown in per unit, i.e. the voltage and current are normalized using the  $VOC$  and the  $ISC$  respectively, in order to illustrate better the effects of the irradiance on the V-I and V-P curves.

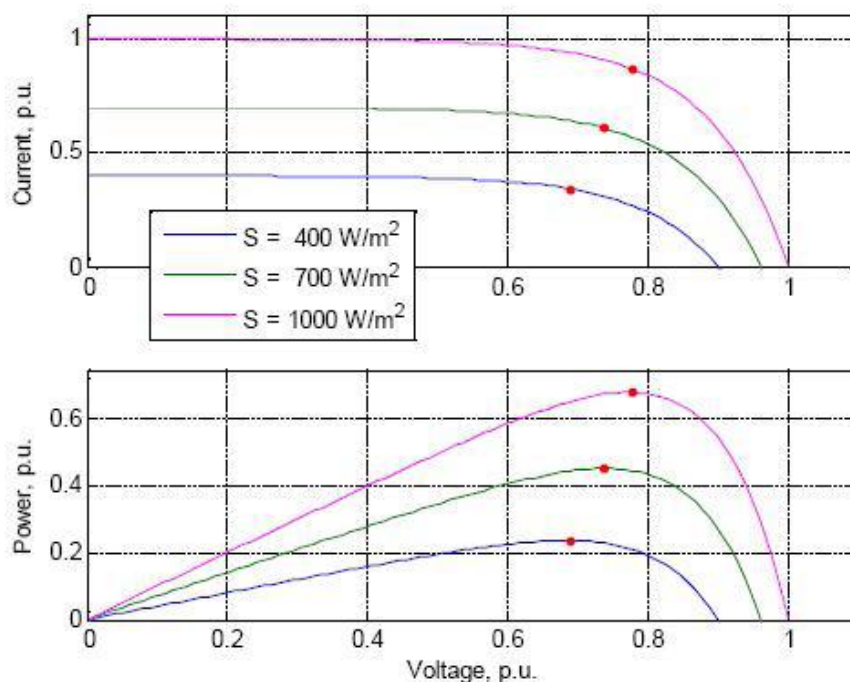
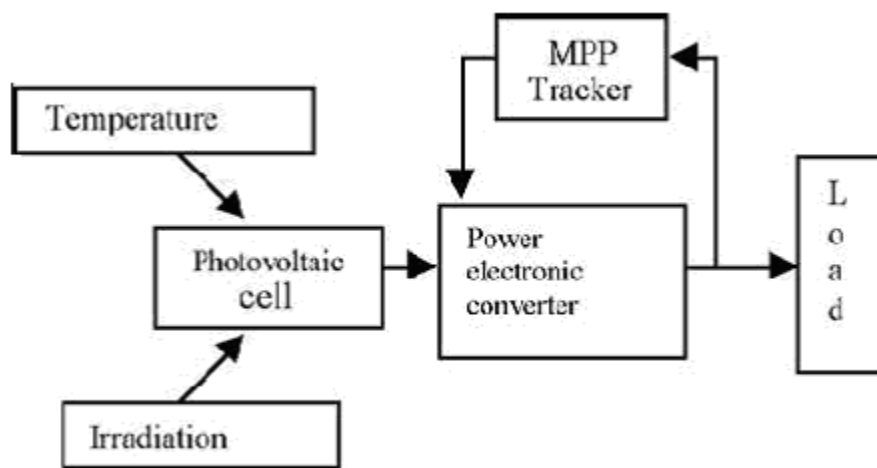

Figure 3: V-I and V-P curves at constant temperature (25°C) and three different insolation values

Two important factors that have to be taken into account are the irradiation and the temperature. They strongly affect the characteristics of solar modules. As a result, the MPP varies during the day and that is the main reason why the MPP must constantly be tracked and ensure that the maximum available power is obtained from the panel. The effect of the irradiance on the voltage-current (V-I) and voltage-power (V-P) characteristics is depicted in Figure 4, where the curves are shown in per unit, i.e. the voltage and current are normalized using the  $VOC$  and the  $ISC$  respectively, in order to illustrate better the effects of the irradiance on the V-I and V-P curves.

#### IV. MPPT Technique

A tracker consists of two basic components as shown in Fig 4, a switch-mode converter and a control section with tracking capability. The switch-mode converter is the core of the entire supply. The main component of the MPPT is the DC-DC buck converter that steps down the solar panel output voltage to the desired load voltage.

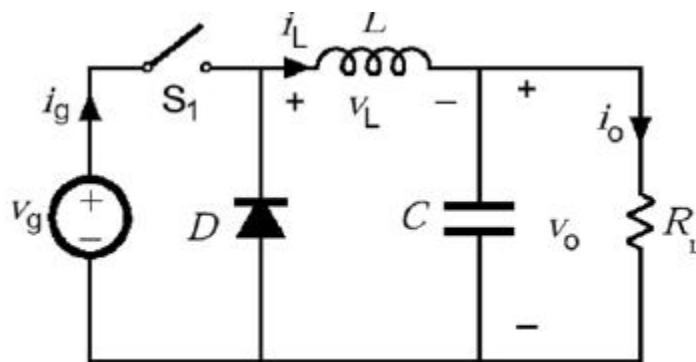

**Fig: 4.1 Basic components of a maximum power point tracker**

To ensure that the solar module operates at the maximum operating point, the input impedance of the DC-DC converter must be adapted to force the solar module to work at its maximum power point. Depending on the load requirement, other types of DCDC converters can be employed in the MPPT design. For example, the boost converter can output a higher voltage from a nominal input voltage; other types of DC-DC converters include the buck-boost converter, CUK converter and full-bridge converter.

The buck converter uses energy storage components such as inductors and capacitors to control the energy flow from the solar module to the load by continuously opening and closing a switch. The switch is usually an electronic device

That operates in two states: in the conduction mode (on), the output of the solar cell is connected to an inductor while in the cut-off mode (off), the output of the solar module is disconnected from the inductor. The buck converter also contains a forward biased diode that provides a return path for the current in the Cut-off State.



**Fig: 4.2 Basic circuit of a buck converter**

The switch is actually a MOSFET that is controlled by a PWM signal. The switch conducts on and off to control the voltage level at the inductor. The voltage at the inductor has a rectangular waveform that is later filtered by the LC combination to produce a quasi-continuous voltage at the output. The average value of the rectangular waveform can be adjusted to control the length of the conduction and cut-off states of the switch. The on time of the switch is related to its time period such that  $t_{on} = DT$ , where  $D$  is the duty cycle. In the ON state, current flows from the module through the inductor causing the inductor to store energy. In this state the diode is in reverse bias and no current flows through it. In the OFF state, the off time is  $t_{off} = (1 - D)T$  and the current in the inductor causes the diode to become forward biased. The diode turns ON and provides a path to maintain the continuity of current through the inductor.

The duty cycle can be adjusted to set the output voltage of the converter to the desired value. For an ideal DC-DC converter, the duty cycle is the ratio between the output voltage and the input voltage,  $D = V_o/V_i = I_i/I_o$ . The duty cycle is allowed to be set such that the input voltage to the DC-DC converter is always set at the solar module's maximum power point voltage. The duty cycle is set by means of a pulse width modulation signal used to control the MOSFET on and off states. Various control methods carry out the task of varying the duty cycle to match  $R_0$ . Different MPPT control algorithms help to track the peak power point of the solar PV module automatically. The following methods are analyzed which are used to control the MPPT

- Incremental conductance maximum power point method
- Constant Voltage maximum power point method
- Constant Current maximum power point method
- Perturb and Observe maximum power point method
- Fuzzy logic based maximum power point method
- Neural network based maximum power point method
- Neuro-Fuzzy based maximum power point method.

MPPT systems are used mainly in systems where source of power is nonlinear such as the solar PV modules or the wind generator systems. MPPT systems are generally used in solar PV applications such as battery chargers and grid connected standalone PV systems.

**a] Battery charging** – One of the applications is in Charging of batteries (lead acid/NiCad) which are used for the storage of electrical energy. If this energy comes from the solar PV

systems then fast charging of the battery is done with the help of the MPPT charge controller.

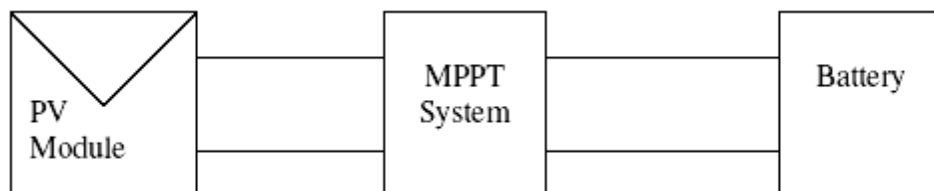

**Fig: 4.3 Battery charging application of MPPT.**

b) Grid connected and standalone PV systems- In grid connected or standalone PV systems the solar arrays supply power to the grid or to the local load. A dc/dc converter is used as the array voltage is dc, and as grid voltage is ac a dc/ac converter must be used.

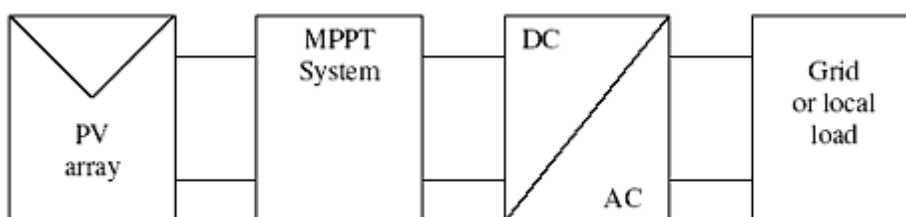

**Fig: 4.4 Grid connected application using MPPT**

Before a dc/ac converter, a dc/dc converter is used which serves the purpose of maximum power point tracking as explained earlier. Due to maximum power tracking always the peak power is transferred to the grid or to the local load. Bypass and Blocking Diodes In conventional MPPT configurations, the energy produced by the shaded cell as complete power extraction from the PV array can be preserved because it is inhibited by the cell. A cell will be open

Circuited or fully damaged if it dissipates more than the maximum tolerated power in the hot-spot stage of non-uniform irradiation. Figure 4.3 shows that the bypass diodes (D1 to D4) are connected in parallel with the panels, and a blocking diode (Db) is in series with the battery. A bypass diode in reverse biased condition acts as a generator with small internal voltage and leakage current, and the panels are in normal mode operation. However, the bypass diode can sustain a sudden increase in when one cell is shaded; its bypass diode behaves as a load and allows current to flow through it from the rest of the cells, which maximizes the performance of the system [9]. By contrast, a shaded cell can be excluded by using a bypass diode to avoid impediment in power collection from the remaining cells, which results in energy loss from the shaded cell [6,3]. In thin-film CIGS, the bypass diode cannot protect the modules from damage [5]. The bypass diode in the panel produces multiple power peaks on the P-V curve. A power loss can be minimized if a blocking diode (Db) is used to stop current flow from the battery to the panels at night when the voltage across the cells reaches zero [6]

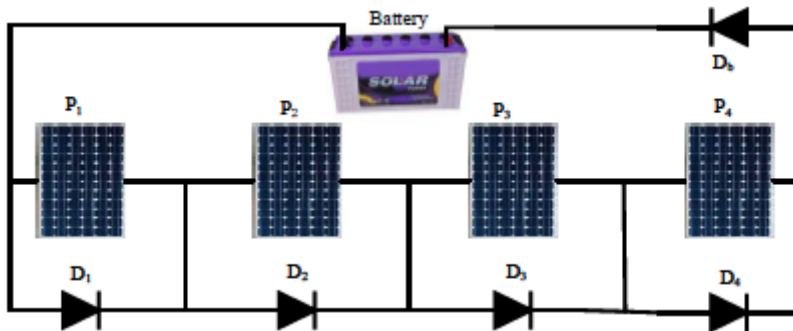

power and temperature [7]. A bypass switch (Mosfet) or a bypass diode is also used in satellite stems to mitigate hot-spotting damage in the PV strings [1]. A bypass diode starts functioning if 20% of the panel is shaded. When the shaded portion of a module exceeds 20%, the power loss is alleviated due to a huge current flowing through the bypass diode [8].

When one cell is shaded, its bypass diode behaves as and allows current to flow through it from the rest of the cells, which maximizes the performance of the system [8]. By contrast, a shaded cell can be excluded by using a bypass diode to avoid impediment in power collection from the Remaining cells, which results in energy loss from the shaded cell [9]. In thin-film CIGS, the bypass diode cannot protect the modules from damage [10]. The bypass diode in the panel produces multiple power peaks on the P-V curve. A power loss can be minimized if a blocking diode (D<sub>b</sub>) is used to stop current flow from the battery to the panels at night when the voltage across the cells reaches zero [10].

**V.Result and Simulation**

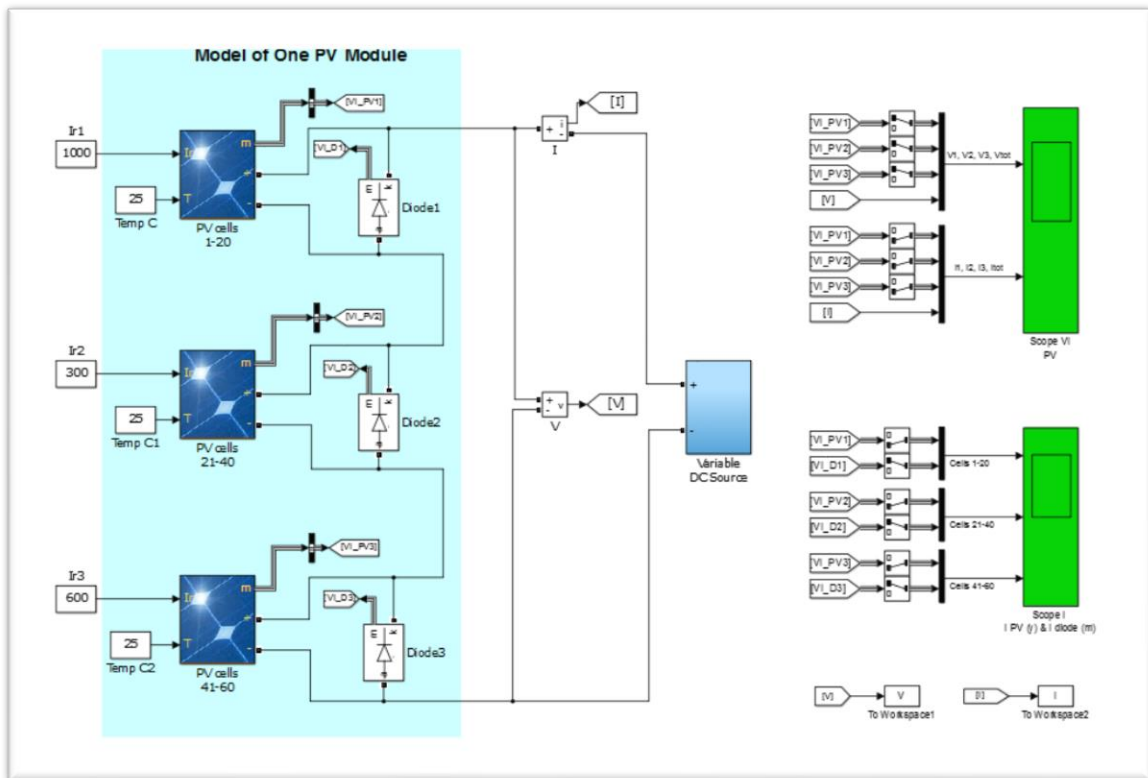

**Fig.(5.1)PVs array with irradiation**

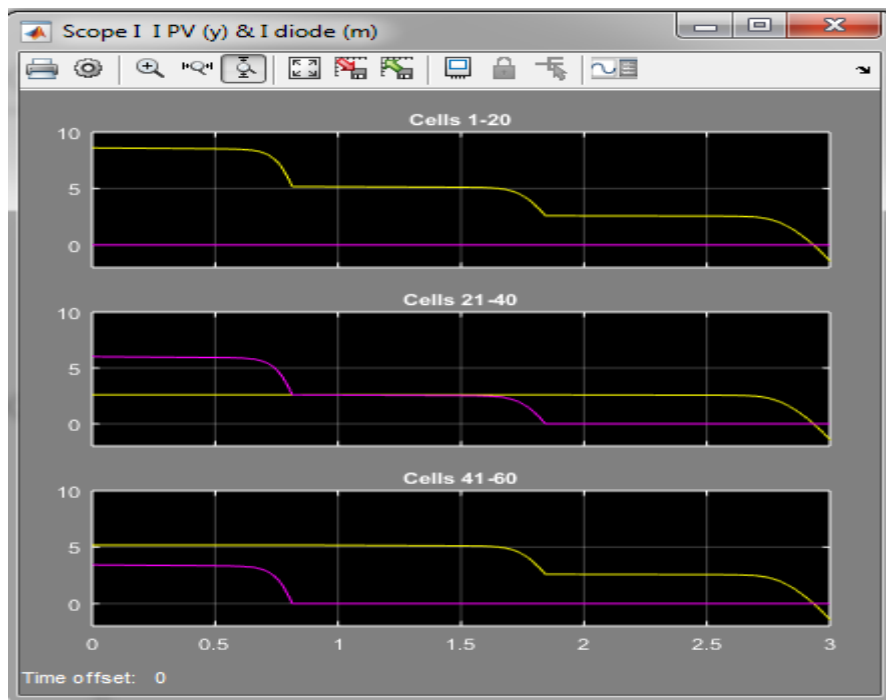

**Fig. (5.2) Output current, voltage and power of boost converter without P&O algorithm**

**Table 1: A COMPARISION BETWEEN REDUCTIONS CRACK OF EFFECTIVE AREA OF SOLAR PANEL WITH REDUCTION OF SOLOR EFFICIENY.**

S.no.	EFFECTIVE AREA	OUTPUT VOLTAGE	OUTPUT CURRENT Amp.	$P_{out}$	$P_{in}$	Irradiation
1	1.00	15	8	150	250	40
2	1.50	20	9	200	300	50
3	1.90	25	11	250	370	60
4	2.00	30.1	13	300	390	70
5	2.15	35	14	350	400	80



## **VI. Conclusion**

In this study simulation of PV generators that are capable of producing different output powers are used. In this simulation output power is measured and DC/DC converter is controlled by using MPPT and without using MPPT. In PV energy conversion systems using MPPT increases output power and efficiency. This results in usage of fewer amounts of panel and reduced cost. In rapidly changing weather conditions P&O algorithm can occasionally make the system operating point far from MPP. The oscillation is shown in Fig. 6, 10. In simulation linearly changed illumination value is used thus less oscillation is observed then real experiment. This study focuses on improving algorithm and eliminating oscillation problems in P&O MPPT algorithm. Particularly, when variability increases as a result of factors such as partial shadowing and cloudy weather, these oscillations are bound to affect the system more. Therefore, it is suggested that this improvement attempts for the algorithm will yield positive results in terms of system efficiency. It is also possible to suggest that changes in the algorithm will pose no difficulties in terms of hardware, which makes it suitable for experimental purposes. In the upcoming studies, it is required to improve the algorithm as far as hardware is concerned. By the spread of electric vehicles and portable electronic devices, battery charging problem is further increased the importance of the wireless energy transmission. In this study, the most important renewable energy sources, solar energy, is integrated with wireless energy transmission by using conventional system and system using MPPT. Both systems are compared experimentally and this comparison results in systems using MPPT are more efficient than the conventional systems. For further studies both temperature and illumination value can be changed separately or simultaneously.

## **References**

1. S. Liu and R. Dougal. **Dynamic multiphysics model for solar array Energy Conversion**, IEEE Transaction, Vol.17, pp. 285-294, Jun 2002.
2. C. M. J.A. Gow. **Development of a photovoltaic array model for use in power- electronics simulation studies in Electric Power Applications**, IEEE Proceedings, Vol. 146, pp. 193-200, March 1999.
3. G. Walker. **Evaluating MPPT converter topologies using MATLAB PV model**, J. Elect. Electron. Eng., Australia, IE Aust., Vol. 21, No. 1, pp. 49–56, 2001.
4. W. Xiao, W. Dunford, and A. Capel. **A novel modeling method for photovoltaic cells**, Power Electronics Specialists Conference, 2004. PESC 04, IEEE 35th Annual, Vol. 3, pp. 1950-1956, June 2004.
5. D. Hohm and M. Ropp. **Comparative study of maximum power point tracking algorithms using an experimental, programmable, maximum power point tracking test bed**, Photovoltaic Specialists Conference, 2000. Conference Record of the Twenty-Eighth IEEE, pp. 1699-1702, 2000
6. A. Kassem and M. Hamad. **Microprocessor- based controller Multi –Function for Solar Tracking System**, IEEE Proceedings, 2011.
7. D. Sera, T. Kerekes, R. Teodorescu, and F. Blaabjerg. **Improved MPPT method for rapidly changing environmental conditions**, Proceedings IEEE Int. Ind. Electron. Symp., Jul. 2006, Vol. 2, pp. 1420–1425.
8. V. Salas, E. Olias, A. Barrado, and A. Lazaro. **Review of the maximum power point tracking algorithms for standalone photovoltaic systems**, *Sol. Energy Mater. Sol. Cells*, Vol. 90, No. 11, pp. 1555–1578, July 2006.

**8. M. C. Alonso-Gracia, J. M. Ruiz, and F. Chenlo. Experimental study of mismatch and shading effects in the Solar Panel**, Solar Energy Mater. Solar Cells, Vol. 90, No. 3, pp. 329–340, Feb. 2006.

**9. H. Kawamura, K. Naka, N. Yonekura, S. Yamanaka, H. Kawamura, H. Ohno, and K. Naito. Simulation of  $I$ - $V$  characteristics of a PV module with shaded PV cells**, Solar Energy Mater. Solar Cells, Vol. 75, No. 3/4, pp. 613–621, Feb. 2003.

## **Quality of Work Life**

### **Rashmi\***

#### **Abstract**

Good Quality of work-life is vital for an association to draw in and to hold gifted and skilled representatives. Keeping in mind the end goal to make due in the aggressive market as a result of Liberalization, Privatization, and Globalization and to limit the whittling down rate of workers the QWL activities are Important. The reason for this exploration is to research and distinguish the criticalness of workplace towards the execution and further more to ponder the viability of the QWL in the association.

#### **Introduction**

The present period is a time of information laborers and the general public in which we are living has come, to be known as learning society. The scholarly interests have overshadowed the physical endeavors.

Some learning laborers work for over 60 hours per week. Thus, their own side interests and interests conflict with their work. Life is a package that contains every one of the strands together and henceforth the need to adjust work existence with other related issues.

One must have both love and work in one's life to make it solid. Gone are the days when the need of representatives used to be for physical and material needs. With the expanding movement of the economy towards information economy, the importance and nature of work life has experienced an extreme change.

#### **Objectives**

- To make an inspirational disposition
- To increment profitability
- To enhance way of life of the general population

#### **Real Issues in QWL**

- Pay and steadiness of workers
- Job Security
- Occupational Stress
- Adequacy of assets

#### **Literature Review**

Linda K. Johnsrud (2006) did her exploration on Quality of workforce work life in the University of Hawaii to portray the progressions in QWL from 1998 to now. The goal of the examination was to discover the current level of fulfillment on QWL. Factors were utilized as a part of Relations with the network benefit, staff connection, compensation office seat, grounds administration and statistic factors were utilized as a part of this study, and the outcome demonstrated that compensation was one of the principle variables for fulfillment of the workers.

J. Gnanayudam & AjanthaDharmasiri (2008) in their article focused on the Influence of nature of work life on authoritative responsibility by completing an examination on unacceptable level of responsibility among laborers in medium and huge associations in

---

\* Research Scholar, Department of Management, DCRUST University, Murthal, Haryana

the attire business in Sri Lanka. The outcome demonstrated that QWL has a positive huge connection with the dedication variable and mediator impact of HRDC variable.

W.N. thalang et al. (2010) examined on nature of work life pointers as a CSR of electrical and gadgets private Organizations in Thailand. The target of the examination discovered the nature of Work Life Indicators as a Corporate Social Duty. The outcome demonstrated that QWL gives a sign of a powerful CSR, building up a decent Nature of Work Life (QWL) is urgent.

### **Methodologies or Techniques for Improvement**

A portion of the vital systems for enhancing the nature of work life are: 1. job Enrichment 2.job Rotation and 3. Quality Circles (or Self-oversaw Work Teams)

#### **Job Enrichment**

Under customary administration, the standard of division of work and specialization was connected so an individual could complete a specific work all the more effectively. Be that as it may, this made the activity of laborers dreary. They began feeling exhausted by doing likewise work over and over. Administration likewise began acknowledging it as a procedure of dehumanization.

Kerzberg in his two-factor hypothesis of inspiration endeavored to utilize the activity as a medium of creating individuals and changing some hierarchical practices. Employment advancement can prompt an expansion of occupation substance. It likewise builds up the ability of workers who willfully approach to share higher obligations.

The term nature of work life has turned out to be prevalent after 1970. Research is going ahead to discover the new ways and intends to enhance QWL.

#### **Job Rotation**

A vertical employment revolution implies advancement while an even activity pivot implies exchange to some other activity. Occupation turn makes a worker to take in the new activity at the new seat consequently making enthusiasm for the new activity. The issues related with specialization, for example, fatigue and tedium are consequently evacuated as the laborer moves toward becoming generalist from authority.

#### **Quality of Circles**

The idea of Quality Circles was made well known in Japan in 1960 by K. Ishikawa. Japan has picked up a ton by applying the Statistical Quality Control (SQC) systems for creation. Quality circles can be characterized as a little gathering of a few people (perhaps 3 to 12) who meet for a hour consistently to recognize, examine and take care of the issues identified with their work. The arrangements are sent to the administration for usage. Quality Circles build up a culture of investment among the laborers. It likewise mirrors the popularity based set up where the administration keeps full confidence in the representatives and furthermore there is an entire comprehension between the administration and specialists.

#### **Conclusion**

Literary works surveyed have demonstrated that QWL is a multidimensional develops, these develops must be consider amid the activity configuration process. The writing would likewise delight the commitment of the three methodologies of QWL imperative segments of with the representative fulfilment what's more, representatives' supposition on QWL in various divisions.

### **Bibliography**

Linda K. Johnsrud (2006) IOSR Journal Of Humanities And Social Science (IOSR-JHSS) Volume 19, Issue 9, Ver. V (Sep. 2014), PP 71-80.

J. Gnanayudam & AjanthaDharmasiri (2008) The Influence of Quality of Work-life on Organizational Commitment: A Study of the Apparel Industry, Sri Lankan Journal of Management Volume 12, Nos. 3 & 4, July-December 2007.

W.N. thalang et al. (2010) Frontiers in Automobile and Mechanical Engineering IOP Publishing IOP Conf. Series: Materials Science and Engineering 197 (2017).

Perera, T. Employee Commitment : A Study of Selected High Performing Companies in Sri Lanka, Sri Lankan Journal of Management, 7 (3& 4), 2002.

Phusavat, K. Examination into the Interrelationships between Quality of Work Life and Productivity, Unpublished Doctoral Dissertation, Dept of Industrial Engineering Kasetsart University, Bangkok, 2001.

Pillai P.R. (2004) Learning Orientation Newsletter: A Study on Learning Orientation and HRD Climate in Banks. <http://www.trainingplace.com>, accessed on 28-07-2006.



## **An Algorithm to Develop Time Table Tabling Schedule and Management System Software using Heuristic Approach**

**Akanksha Bansal Chopra, Manisha Vashisth, Anchal Dua, Divya Singal&Sneha Bharti\***

### **Abstract**

The traditional approach to frame timetables with no use of computers is very time consuming and cumbersome. Manual detection of clashes in terms of rooms or faculty is involved. Another manual effort is to redraw the same time table differently, according to the need of different users. This project proposes a more practical approach that aims to overcome these limitations and reduce the need of excessive paperwork. Secured with a Login ID and Password, the “Time Tabling Schedule and Management System (TTSMS)” is software that allows the user to input the timetable and have its clashes resolved and highlighted instantly. The timetable is then stored and can be retrieved at any point of time molded according to the need of the user. It can be viewed Daywise, Roomwise, Facultywise, Departmentwise, Lecturewise, Coursewise and all Choice Based Credit System (CBCS) variants such as Generic Elective (GE), Ability Enhancement Compulsory Course (AECC), Skill Enhancement Course (SEC).

**Keywords:** CBCS, TTSMS, GE, AECC, SEC, room clash, faculty clash

### **1. Introduction**

Combining several atomic time tables used for making master time table with various constraints is a tricky task. Timetables are very likely to require multiple updates. These factors make time table creation an error prone task. Using computers to handle this makes updating entries easy and eco friendly thereby saving paper. TTSMS Software helps in removing clashes and leads in reducing manual effort. It enables the user to enter the time table of each faculty once into the software and then retrieve the schedule of entire college. It can then be viewed Daywise, Roomwise, Facultywise, Departmentwise, Lecturewise, Coursewise and all CBCS variants such as GE, AECC, SEC. Password protection helps to maintain safety of data and schedules. The software satisfies various user requirements.

#### **1.1 Related Work**

In 2015, Prof. Er. Shabina Syed and others, proposed an evolutionary algorithm for a practical Time Tabling approach that is capable of taking care of both hard and soft constraints required specially for preparing Time Table in colleges.<sup>[1]</sup>

In 2015, Dr. Issa S. I. Ottorum, in his paper, compared two methods of designing a Timetable and discussed advantages and disadvantages of these methods over each other.<sup>[2]</sup>

In 2011, Masri Ayob and others, proposed an Intelligent commercial strategy that is capable of producing a high quality examination Timetabling Software.<sup>[3]</sup>

#### **1.2 Problem Statement**

The proposed software works on solving a basic problem of every university and school, the TTSMS Software. Making a Timetable is time consuming and brainstorming work but fitting it with the entire university's or school's overall schedule is a more exhausting

---

\*Department of Computer Science, Shyama Prasad Mukherji College For Women (University of Delhi)

work, the one needs to take care of every clashes in rooms or in faculty . The “Time Tabling Schedule and Management System Software” focuses on this real world problem of Shyama Prasad Mukherji College (For Women), Delhi University. SPM comprises of 13 Departments that offers 15 different courses. Integrating the Time-Tables of these various courses leads to room clashes as well as faculty clashes that may affect the overall college’s schedule and discipline and leads to chaos among students as well as faculty. It resulted in inconvenience for many and needed a urgent solution. Summing up all the software offers less paper work, less manual work, more accuracy and efficiency.

### **1.3 Why we developed this software?**

There was an utmost need to develop software that could relieve the time table committee from the hectic work of resolving problems that occur in managing and making a timetable that is ready to use and free of flaws. Moreover as technology is being adapted throughout the world and made things easier and simplified the lengthy process in one click.

Earlier in SPMC every department submitted its own individual Timetables that were plotted manually on a huge sheet of paper to avoid clashes and they were manually allotted rooms by the Time-Table Committee that took days to complete. Even after their precise calculations, there are very bright chances that the time-table contains some clashes .The manually plotted timetable has then to be converted in a format that can be displayed on college’s website for students which adds on to the work and takes a good amount of time. The software makes a complete formatted time-table that is ready to upload and print in much lesser time.

Handling hundreds of sheets together is cumbersome and may leads to human error that are harder to rectify in less time .The TTSMS became delicate with the introduction of CBCS system in the university that provides flexibility to students to choose subjects from different courses . With its introduction in the university, timetables varied as a new papers known as GE, AECC, SEC has to be incorporated in the time-table .This requires intensive Inter-Department timetables integrating which resulted in a huge number of errors and clashes and to remove those errors and clashes it takes a lot of time. The proposed software makes this cumbersome task easy, makes integrations less complicate.

### **1.4 Problem Formulation**

The notations used in the proposed software can be written as follows:

- A represents the set of attributes as:

$A = \{W, T, C, F, S, R, SE, G, D\}$

- W represents the set of all weekdays
- $W_i$  represents  $i^{th}$  day of a week
- R is the number of available rooms
- $R_i$  is the  $i^{th}$  room number
- $R_{ij}$  is the clash matrix where each element denoted by  $R_{ij}$  where  $(i, j \in \{1, \dots, R\})$  is the number of rooms occupied by faculty  $f_i$  and  $f_j$  where  $R_{ij}=0$  for  $i=j$
- F represents the set of available faculties
- $F_i$  is the  $i^{th}$  faculty
- $F_{ij}$  is the clash matrix where each element denoted by  $F_{ij}$  where  $(i, j \in \{1, \dots, F\})$  is the time slot  $t_i$  and  $t_j$  occupied by a faculty where  $F_{ij}=0$  for  $i=j$
- C is the set of all course

- $C_i$  represents  $i^{th}$  cours
- $T$  is the set of available time slots for lecture
- $S$  is the set of semesters
- SE represents set of sections
- G is set all GE variant
- $T_i$  represents the  $i^{th}$  time slot
- $G_{ij}$  is the  $j^{th}$  element of  $i^{th}$  GE variant
- $D$  represents the set of available departments
- $D_i$  represents the  $i^{th}$  department

Constraints to be taken into considerations are as follows:

1. Each room must be assigned to a single faculty at a particular time slot (except laboratories) //

Initially each room and every faculty is not assigned to any class i.e  $r_i=0$  and  $f_j=0$  for  $I \in \{1, \dots, R\}$  and  $j \in \{1, \dots, F\}$

$$\sum_{r_i=1}^{R-1} \sum_{j=i+1}^R R_{ij} \beta(r_i, f_j) = 0$$

where  $\beta(r_i, f_i) = \begin{cases} 1 & \text{if } f_i = f_j \\ 1 & \text{otherwise} \end{cases}$

2. No faculty can take two different classes in the same time slot

Initially faculty is not assigned to any class  $f_j=0$  for  $j \in \{1, \dots, F\}$

$$\sum_{t_i=1}^{F-1} \sum_{j=i+1}^F F_{ij} \alpha(t_i, t_j) = 0$$

where  $\alpha(r_i, f_i) = \begin{cases} 1 & \text{if } t_i = t_j \\ 0 & \text{otherwise} \end{cases}$

### 1.5 Proposed Work

We propose to develop a software named as, “Time Tabling Schedule and Management System” Software using a Heuristic Approach. We critically analysed our problem statement and divided our proposed work in two subsections as:- Workflow and Architectural design for the software, finally to be implemented . The workflow helps in better understanding of the problem statement. The Architectural Design gives a brief and clear pictorial description of flow of data in the software.

#### 1.5.1 Workflow of TTSMS Software

A workflow for the system design provides a better understanding and reusability of the system’s various components. The Architectural Design for TTSMS Software may be studied as under.

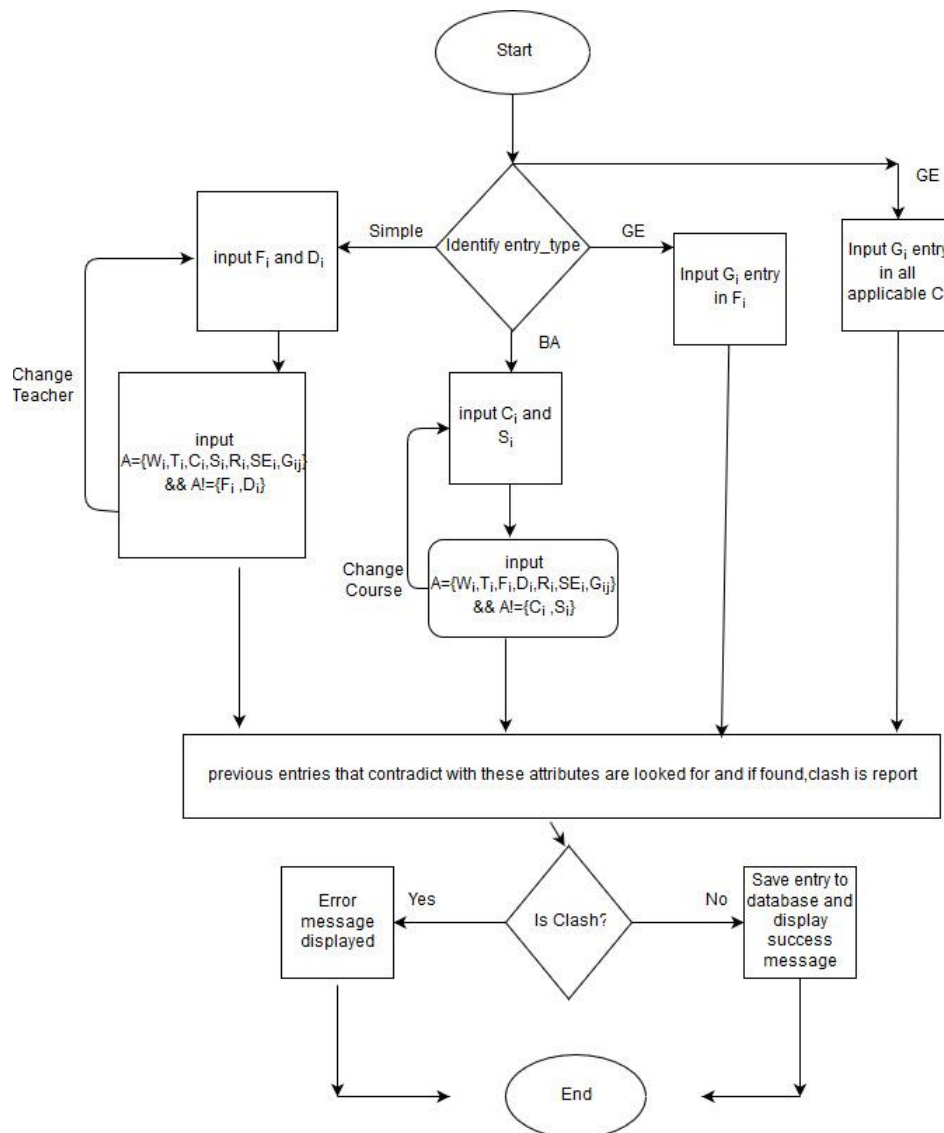

Fig 1.1 Workflow for TTSMS Software

### 1.5.2 Architectural Design

The server communicates with the physical layer that contains the homepage, login and master details functionality. Directly connected to the physical layer is the logical layer that includes the time table entry block. It is divided into several blocks like Coursewise, Facultywise, year, BA program and CBCS variants like AECC, GE; SEC. Directly visible to the user is the implementation layer. It contains the functionality to display the time table as per various actors according to different attributes like day, room, lecture, course or teacher. The option to view software development team is available via credits. There is also an option to view the list of all the departments active in the college. Authorization, authentication, login, exception handling, security are some of the cross cutting concerns.

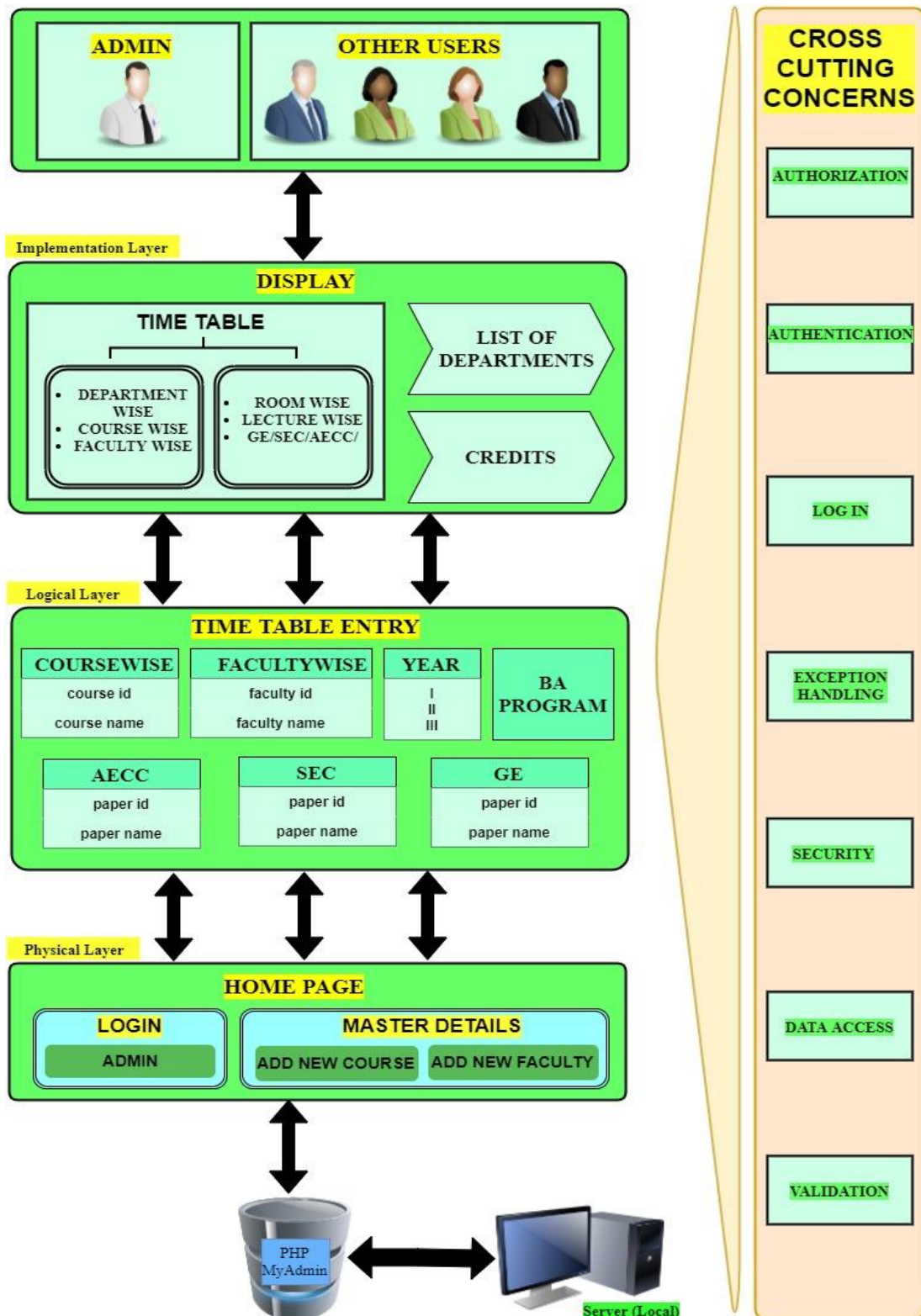

Fig. 1.2 Architectural Design used for the development of TTSMS Software



## **2. Implementation**

This software has been implemented as per the college's requirement, frequent updations were made regularly to keep it updated. We have not used any predefined algorithm to develop this system and have defined our own need algorithms that are reusable and easy to understand.

This software is being used by the time table committee of SPMC from the last 1.5 years and is being much appreciated by the college and also outside it. It had made many hectic tasks easier and quicker and resulted in an efficient piece of work.

### **2.1 Algorithms**

The various algorithms that have been applied for the development of TTSMS Software, using heuristic approach are discussed as under.

#### **2.1.1 EditRecord()**

The algorithm allows the user to edit a previously saved record. An edit form is displayed with all the previous values for each attribute and the user can edit any number of attributes as per requirement. Any clashes are re-examined and if the updated record is valid, changes are saved to database.

1. Display->Attribute A

2. Edit->  $A_i$

3. Call function checkclash();

#### **2.1.2 CheckClash()**

CheckClash() function is the module that deals with record validation. It checks if the new room requested for a lecture is available or not by thoroughly checking previous records. It also checks if the professor is free on the given slots or not. If no problem or clash arises the record is safely saved to database and a success message is displayed, otherwise an error message is shown displaying where the room or lecture is already occupied so that necessary updates can be made in conflicting slots.

CheckClash()

{

GEclash=0; BAclash=0; Spmclash=0; //Set flags

//check GEspmtt

Search Table GEspmtt where  $R = \text{new } R_i$  and  $W = W_i$  and  $T = T_i$

if(records!=0){

    if( $R_i=35 \parallel R_i=3 \parallel R_i=38$ )

    {

        GEclash=0;

    }

    else

    {

        GEclash=1; display "  $R_i$  is busy";

    }

}

Search Table GEspmtt where  $F = \text{new } F_i$  and  $W = W_i$  and  $T = T_i$

if(records!=0){

    GEclash=1; display "  $F_i$  is busy";

}

//check BAspmctt

Search Table BAspmctt where R= new R<sub>i</sub> and W=W<sub>i</sub> and T=T<sub>i</sub>

```
if(records!=0){
    if(Ri =35 || Ri =3 || Ri =38)
    {
        BAclash=0;
    }
    else
    {
        BAclash=1; display "Ri is busy";
    }
}
```

Search Table BAspmctt where F= new F<sub>i</sub> and W=W<sub>i</sub> and T=T<sub>i</sub>

```
if(records!=0){
    BAclash=1; display "Fi is busy";
}
```

//check spmctt

Search Table spmctt where R= new R<sub>i</sub> and W=W<sub>i</sub> and T=T<sub>i</sub>

```
if(records!=0){
    if(Ri =35 || Ri =3 || Ri =38)
    {
        Spmcclash=0;
    }
    else
    {
        Spmcclash=1; display " Ri is busy";
    }
}
```

Search Table spmctt where F= new F<sub>i</sub> and W=W<sub>i</sub> and T=T<sub>i</sub>

```
if(records!=0){
    Spmcclash=1; display "Fi is busy";
}
```

if(GEclash=0 && BAclash=0 && Spmcclash=0)

```
{
    write entry to db;
}
else display "Please re-retry with different Attribute A";
}
}
```

### **2.1.3 InsertNewFaculty( )**

This algorithm has been implemented to allow the user to save the details of any faculty that may enter the institution. His/Her name, department are entered. Previous records are checked for similar entries and if any are found, respective records are displayed. This is done to avoid data duplication.

Enter the name, names\_abbrev, D<sub>i</sub> of the new F<sub>i</sub>

Search table teacher\_details to find similar pre-existing records

If (records!=0)

```
{
    Display similar records;
    Display ("Still want to create a new Fi?");
    If(input==Yes)
    {
        Save entry to database;
        Display confirmation message;
    }
    else
    {
        Exit;
    }
}
else
{
    Save entry to database;
    Display confirmation message;
}
```

### **2.1.4 InsertNewCourse( )**

This algorithm has been implemented to allow the user to save the details of any course that may enter the education system. Name, Year and Department of the course are entered. Previous records are checked for similar course entries and if any are found, user is asked to reconsider the addition. This is necessary to keep database free of data duplicacy.

Enter the name, year, D<sub>i</sub> of the new C<sub>i</sub>

Search table course\_details to find similar pre-existing records

If (records!=0)

```
{
    Display similar records;
    Display ("Still want to create a new Ci?");
    If(input==Yes)
    {
        Save entry to database;
        Display confirmation message;
    }
    else
    {
        Exit;
    }
}
```

```
}  
else  
{  
    Save entry to database;  
    Display confirmation message;  
}
```

## 2.2 Screenshots

The system's interface is very user friendly and easy to learn .Every facility that the system provides is easily accessible by the user .Here is a slight glance of the working TTMSS,which is currently in use in SPMC.

### 2.2.1 Login Screen

This is the first screen of the software that greets the user. For safety purpose, any user without the correct combination of email and password is denied the access to the software. This is done to shield the lecturer's schedule against any unauthorized change.



### 2.2.2 Teacher Wise Time Table Entry

Any user who wishes to enter the lecturer's time table shall make use of this screen to feed the record into the database, which is validated for clashes and subsequently saved as a permanent record if is found to be conflict free.

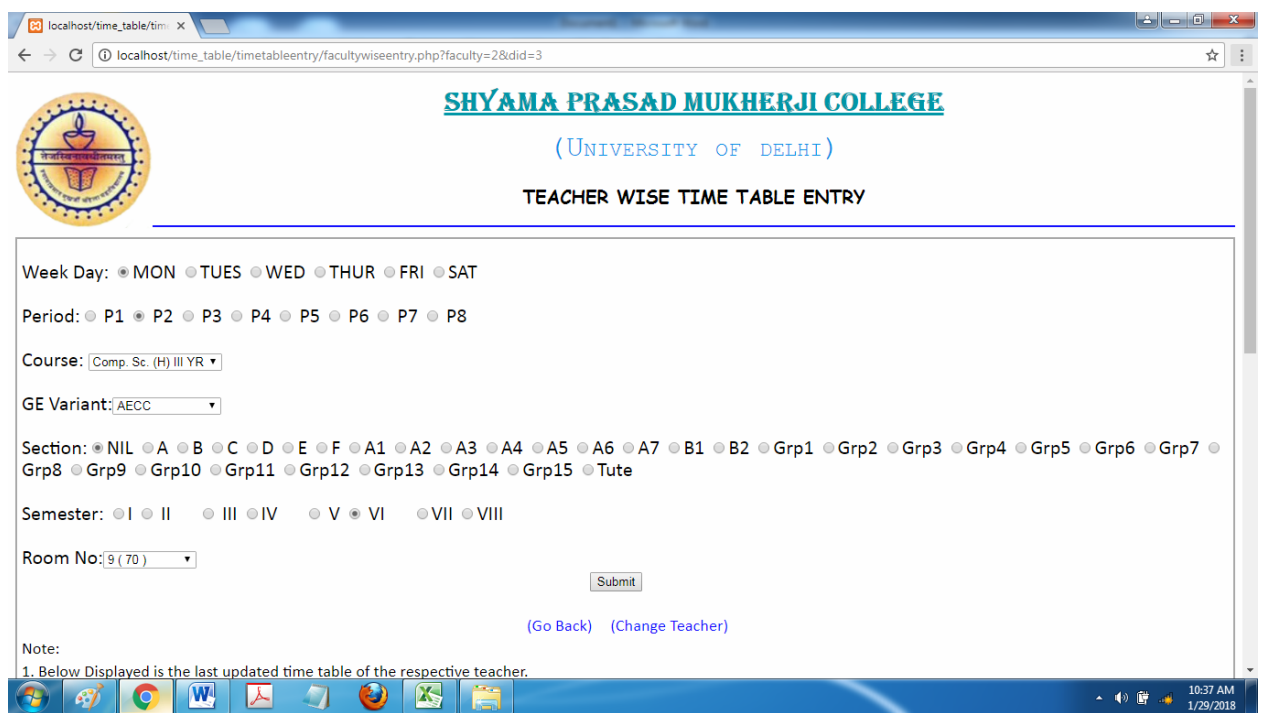

### 2.2.3 Add New Teacher

This screen allows the user to save the details of any faculty that may enter the institution. His/Her name, department and abbreviated names are entered. Name abbreviations are necessary and must be entered in accordance with the display format set by the head of the institution.



### 2.2.4 Add New Course



This screen allows the user to save the details of any new course that may enter the curriculum. The Name, code; year and Department of the course are entered. Post record validation, details of new course are added and are used directly during entry.

The screenshot displays a web browser window with the URL `localhost/time_table/master/master.php`. The page header features the college logo and the text "SHYAMA PRASAD MUKHERJI COLLEGE (UNIVERSITY OF DELHI)". Below this, there is an "ADD NEW:" section with a horizontal list of 20 departments: 1.applied psychology, 2.commerce, 3.computer science, 4.economics, 5.education, 6.english, 7.family & child welfare, 8.food technology, 9.geography, 10.hindi, 11.history, 12.mathematics, 13.music, 14.philosophy, 15.physical education, 16.political science, 17.sanskrit, 18.sociology, 19.generic elective, 20.b.a. A dark teal navigation bar contains "Course" and "Teacher" tabs. The "Course" tab is active, showing a form with fields for "Department ID:" (value: 1), "Course Name:" (value: App. Psy.), "Course Code:" (value: 3), "Course Abbreviation:" (value: App.), and "Course Year:" (value: III). A "Previous Entries" box shows "App. Psy., App. Psy.". An "ADD" button is at the bottom of the form. The Windows taskbar at the bottom shows the time as 10:42 AM on 1/29/2018.

### 2.2.5 Print Time Table

This screen serves as the final output of the several time table entries done. It fetches all the valid and relevant records from all the tables and divisions present in the database and helps download the time table in format that is suitable for the distribution of the same.

Shyama Prasad Mukherji College  
Akanksha Bansal Chopra (Computer Science)  
TIME TABLE(JANUARY-MAY 2018)  
CourseName/Section/RoomNo

Day	I 08:30 A.M.-09:30 A.M.	II 09:30 A.M.-10:30 A.M.	III 10:30 A.M.-11:30 A.M.	IV 12:00 P.M.-01:00 P.M.	V 01:00 P.M.-02:00 P.M.	VI 02:00 P.M.-03:00 P.M.	VII 03:00 P.M.-04:00 P.M.	VIII 04:00 P.M.-05:00 P.M.
Monday	Comp.Sc.(H) III Yr / - 36	Comp.Sc.(H) III Yr / - 35	Comp.Sc.(H) III Yr / - 35					
Tuesday		Comp.Sc.(H) III Yr / - 1	Comp.Sc.(H) III Yr / - 35	Comp.Sc.(H) III Yr / - 35	Comp.Sc.(H) III Yr / - 65	Comp.Sc.(H) III Yr / - 35		
Wednesday						Comp.Sc.(H) III Yr / - 12	Comp.Sc.(H) III Yr / - 35	Comp.Sc.(H) III Yr / - 6
Thursday				Comp.Sc.(H) III Yr / - 35	Comp.Sc.(H) III Yr / - 35	Comp.Sc.(H) III Yr / - 24	Comp.Sc.(H) III Yr / - 24	
Friday				Comp.Sc.(H) III Yr / - 35	Comp.Sc.(H) III Yr / - 35	GE III YR / - 35		
Saturday								

TEACHER INCHARGE PRINCIPAL

### 2.2.6 Edit Time Table

This screen aids in the updation process of time table making by redirecting to edit forms. Any required changes can be easily made using the 'Edit' option provided the new attributes are conflict free. These changes are permanent and validated as well.

Shyama Prasad Mukherji College  
Akanksha Bansal Chopra  
TIME TABLE  
CourseName/Section/RoomNo [\*Denotes Different TT Entry]

Day	I 08:30 A.M.-09:30 A.M.	II 09:30 A.M.-10:30 A.M.	III 10:30 A.M.-11:30 A.M.	IV 12:00 P.M.-01:00 P.M.	V 01:00 P.M.-02:00 P.M.	VI 02:00 P.M.-03:00 P.M.	VII 03:00 P.M.-04:00 P.M.	VIII 04:00 P.M.-05:00 P.M.
Monday	Comp.Sc.(H) III Yr / - 36 <a href="#">Edit</a> <a href="#">Delete</a>	Comp.Sc.(H) III Yr / - 35 <a href="#">Edit</a> <a href="#">Delete</a>	Comp.Sc.(H) III Yr / - 35 <a href="#">Edit</a> <a href="#">Delete</a>					
Tuesday		Comp.Sc.(H) III Yr / - 1 <a href="#">Edit</a> <a href="#">Delete</a>	Comp.Sc.(H) III Yr / - 35 <a href="#">Edit</a> <a href="#">Delete</a>	Comp.Sc.(H) III Yr / - 35 <a href="#">Edit</a> <a href="#">Delete</a>	Comp.Sc.(H) III Yr / - 65 <a href="#">Edit</a> <a href="#">Delete</a>	Comp.Sc.(H) III Yr / - 35 <a href="#">Edit</a> <a href="#">Delete</a>		
Wednesday						Comp.Sc.(H) III Yr / - 12 <a href="#">Edit</a> <a href="#">Delete</a>	Comp.Sc.(H) III Yr / - 35 <a href="#">Edit</a> <a href="#">Delete</a>	Comp.Sc.(H) III Yr / - 6 <a href="#">Edit</a> <a href="#">Delete</a>
Thursday				Comp.Sc.(H) III Yr / - 35 <a href="#">Edit</a> <a href="#">Delete</a>	Comp.Sc.(H) III Yr / - 35 <a href="#">Edit</a> <a href="#">Delete</a>	Comp.Sc.(H) III Yr / - 24 <a href="#">Edit</a> <a href="#">Delete</a>	Comp.Sc.(H) III Yr / - 24 <a href="#">Edit</a> <a href="#">Delete</a>	
Friday				Comp.Sc.(H) III Yr / - 35 <a href="#">Edit</a> <a href="#">Delete</a>	Comp.Sc.(H) III Yr / - 35 <a href="#">Edit</a> <a href="#">Delete</a>	Comp.Sc.(P) GE III YR / - 35 <a href="#">Edit</a> <a href="#">Delete</a>		
Saturday								

TEACHER INCHARGE PRINCIPAL

### 3. Conclusion

The developed software, TTSMS Software, allows the user to input the time table data. It proves to be a very effective and efficient tool in resolving various clashes, such as

RoomClash, FacultyClash and LectureClash. The software also takes care of various combinational papers such as GE, AECC and SEC. It uses data independence feature wherein any atomic Timetable (such as Daywise, Lecturewise, Roomwise, Facultywise, Departmentwise) can be easily retrieved or modified, without altering any other data or function.

### **3.1 Advantages**

1. The system has a user friendly interface that allows easy user access to various functions.
2. The system provides easy editing and printing facilities.
3. The time table can be displayed in various ways that makes the task much easier.

### **3.2 Disadvantages**

1. The DB has to be manually cleared after every semester
2. No automatic backup included.
3. The system runs on a server, whose speed vary from time to time.

### **4. Future Scope**

Time table management system is open to future enhancements:

1. A backup mechanism can be implemented wherein regular backups of the data can be stored.
2. The software can be linked to a department faculty information system so that names and details of all faculties are updated automatically.
3. The software can be made online via a secure server so that it can support multiple users working concurrently.
4. Database can be implemented using better schemes like master and slave to reduce the overload of database queries.

### **5. References**

- [1] Prof Er. Shabina Sayed.,Ansari Ahmed.,Ansari Aamir.,Ansari Zaeem.,April (2015).,Automated Timetable Generator.,International Journal for innovative Research in Science & Technology | Volume 1 | ISSN : 2349-6010.
- [2] Dr. Issa S. I. Ottoum.,(February 2015)., The Analysis of the Time Table Structure within a Student Information System(SIS)., International Journal for innovative Research in Science & Technology | Volume 7 |.
- [3] Masri Ayob.,Abdul Razak Hamdam.,Salwani Abdullah.,Zalinda Othman.,Mohd Zakree.,Ahmad.,Kiftiah Abd Razak.,Rohana Tan., Norashikin Baharom.,Hilmiah Abd Ghafar.,Rashidah Md Dali.,Nasser R.Sabar.,(2011).,Intelligent Examination Timetabling Software.,Procedia Social and Behavioral Sciences 18.,600-608.
- [4] Anirudha Nanda, Manisha P. Pai, and Abhijeet Gole,August (2012), An Algorithm to Automatically Generate Schedule for School Lectures Using a Heuristic Approach,International Journal of Machine Learning and Computing, Vol. 2, No. 4.

## **A Study on Employee Perception about HRD Climate of Selected IT Companies in Pune City**

**Smeeta S. Kabadi**

**Dr. Shyamkant Shrigiriwar**

### **Abstract**

The objective of this research paper is to study the employee opinion about HRD climate of selected IT companies in Pune city. The researcher has collected the data from 120 respondents by using a well structured questionnaire, and has also used descriptive research design and non probability convenience sampling method for this study. The findings of this study would be helpful to various IT companies in the city.

### **Introduction**

Human Resource Development (HRD) is a process by which the employees of an organization are helped, in a continuous, planned way (Rao 1985).

HRD climate plays a very important role in ensuring the competency, motivation and development of the organization.

Payne and Monsfield (1973) viewed HRD climate as a conceptual linkage between organizations and the individual that intervenes between specific situation attributes or events, and individual perceptions and attitudes.

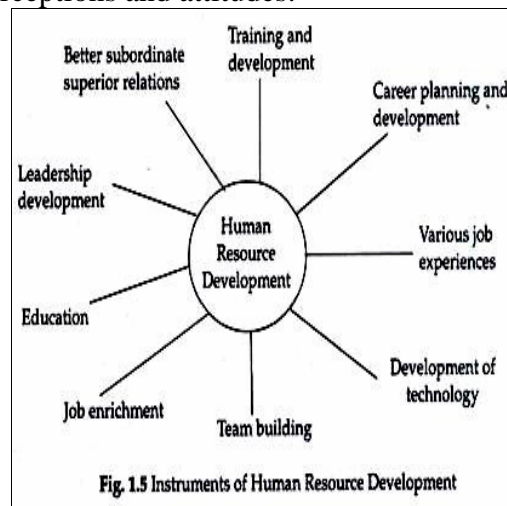

### **IT sector in Pune**

Pune, Maharashtra's second largest city after Mumbai, with the coming of the Information Technology Age in the last decade of the 20th century, has discovered newer pastures. The Maharashtra Chamber of Commerce, Industries and Agriculture (MCCIA) set up a software technology park where many IT businesses were incubated. In the years since, almost every significant name on the national and international IT map has set up a campus here — Wipro, Tech Mahindra, Cognizant, IBM, Mphasis, Veritas, BMC Software to name a few - have set up large campuses, and a large fraction of India's IT revenue is generated from the Pune region.

### **Literature Review**

Nurmi (2001) in his study on “An Investigation of Evaluation of Human Resource Development: A Case Study in the Finish Pulp and Paper Industry” focused on the evaluation of industrial Human Resource Development (HRD). The researcher has emphasized on the existing concepts and models in educational evaluation in order to revise the existing evaluation field.

Bhardwaj and Mishra (2002) in their research study observed that the managers in general, showed a favourable attitude towards HRD policies and practices of the organization. They were satisfied with the developmental policies of top management and as well were happy with the HRD climate prevailing in the organization.

Sreedhar P. Nair's (2005) research study examines and determines the effectiveness of HRM practices in the selected Public Sector Units in Kerala. They learned that HRM policies are beneficial for PSU's in Kerala and its effectiveness is almost equal at all managerial levels.

### **Research Methodology**

#### **Statement of the Research problem**

It stands mandatory to study the HRD climate of IT companies in Pune city. As IT companies are growing rapidly in the city, it thereby becomes necessary to know the perception of employees of the IT companies for their overall growth.

#### **Objectives of the study**

1. To study the concept of HRD climate.
2. To study the employee opinion about the top management.
3. To study the employee opinion about the HRD practices in the organization.

#### **Scope of the study**

The study only deals with HRD climate prevailing about IT companies in Pune city. The researcher has collected data only from IT professionals at middle management level.

The Major factors identified for detailed study are Human Resource Development, Employee Perception, Training and Development, Team spirit, etc.

#### **Methods of Data collection**

- **Primary Data** – Primary data was collected through a verbal, face to face conversation with employees working in IT companies using the questionnaire prepared.
- **Secondary Data** – All relevant secondary data was collected from various sources like the Internet, Books, Magzines, and Articles etc.

#### **Method of analysis and statistical tools**

Data was collected with the help of a well-designed questionnaire, and analysed with the help of MS-Excel.

#### **Research design**

Type of Research Design	Descriptive Research Design
Sampling Technique	Non Probability Convenience Sampling
Sampling Area	Pune City
Sample Size	120
Primary Data	Well-structured questionnaire
Secondary Data	Research papers, Articles, Books, Journals etc.

**Tabulation & Data Analysis**

Measurement Scale: 1- Strongly Disagree, 2- Disagree, 3- Neutral, 4- Agree, 5- Strongly Agree

**Employee opinion about the Top Management**

Indicators	Mean
Top management supports the employees for their development	4.1
Employees are aware about the future plans of the top management	3.6
Promotional decisions taken by top management are purely based on employee performance	3.9
Top management properly coordinate all HRD practices in the organization	4.4
Average Mean	4.0

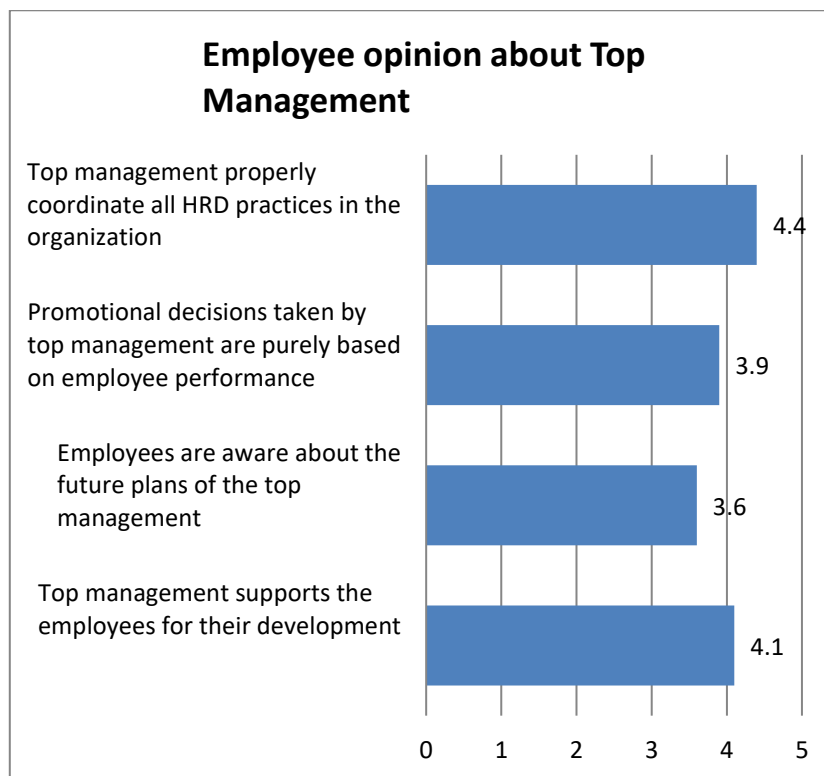

**Employee opinion about Group Cohesiveness**

	Mean
Employees in the organizations are cooperative	4.6
Employees in the organization are self motivated	4.4
Team spirit is present in all the necessary tasks	3.9
Average Mean	4.3



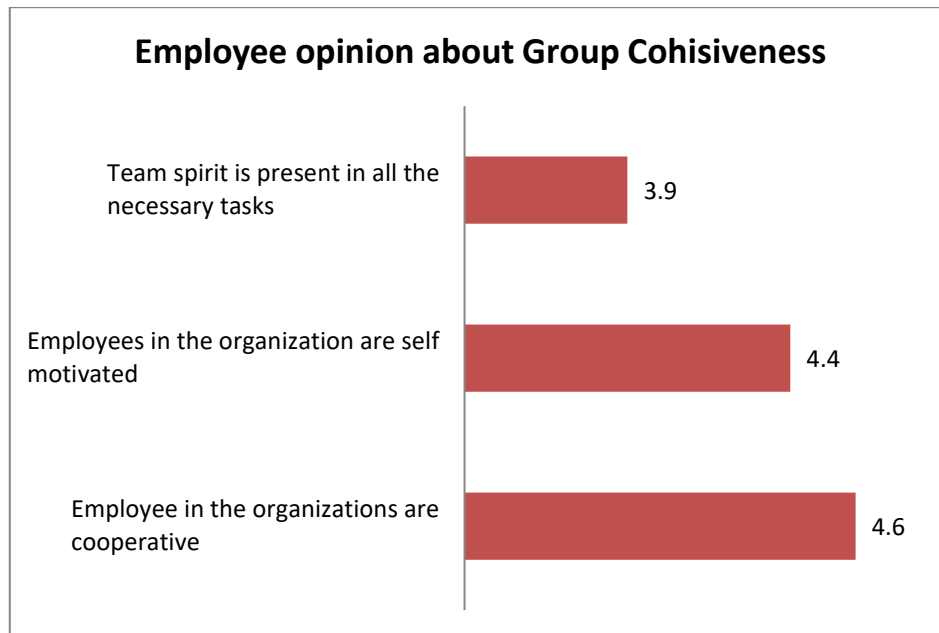

### Employee opinion about the HRD practices in the Organization

	Mean
Training and development programmes are organized at regular intervals	4.6
Awards and Recognition are given for good performance	4.4
Policies of the organization are beneficial in terms of employee development	4.2
Performance appraisal is conducted at regular intervals	4.5
Collaboration between subunits of organization is healthy	4.3
Employee grievance cell handles the conflicts effectively	4.5
Average Mean	4.4

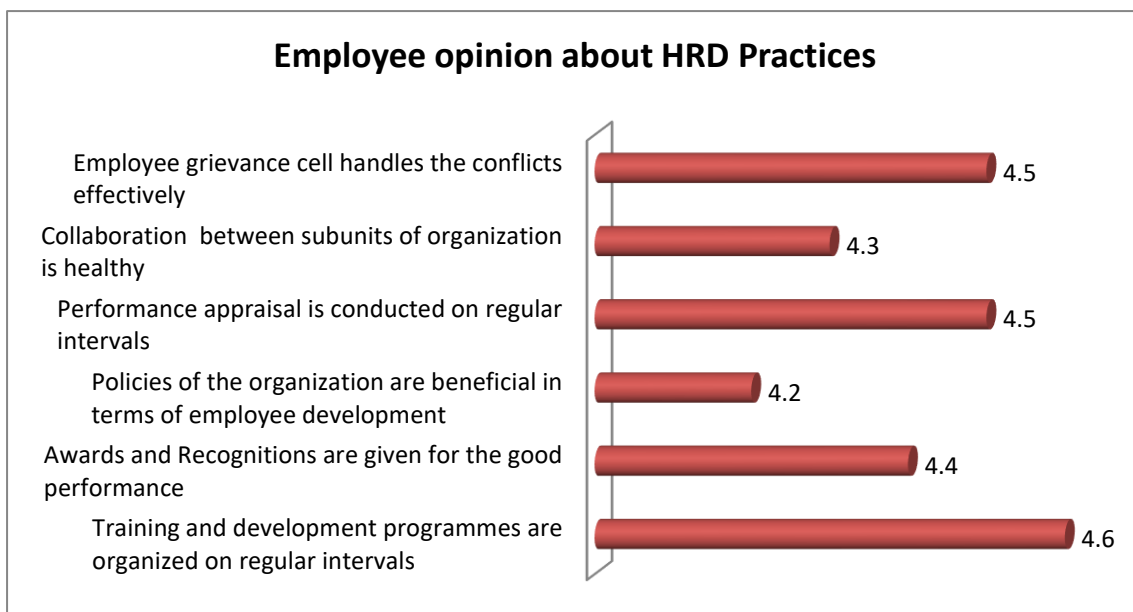

### Findings

- All IT companies follow various HRD practices in their organizations.
- Employees have good opinion about top management's policies, approach, decisions and coordination related with them as the average mean identified is 4.
- It has been observed that employees have group cohesiveness amongst themselves as the average mean identified is 4.3 related to cooperation, team spirit, self motivation and grievance handling procedure.

### Bibliography

#### Books

- Reviewed Work: Human Resource Development in Commercial Banks in India by Neelu Rohmetra Review by: Siladitya Ghosh
- Understanding Human Resource Development: A Research-Based Approach By Jim Mc Goldrick
- Human Resource Management Paperback –by V. S. P. Rao

#### Websites

- [www.slideshare.com](http://www.slideshare.com)
- [www.astd.org](http://www.astd.org)
- [www.expertus.com](http://www.expertus.com)
- [www.wikipedia.com](http://www.wikipedia.com)

#### Research Papers

- Bhardwaj, G., Mishra, P. (2002), HRD climate: An empirical study among private sector managers. The Indian Journal of Industrial Relations, 38(1): 66–80.
- Jain, V.K., Singhal, K.C., Singh, V.C. (1997), HRD climate in Indian industry. Productivity, 37(4):628–39.
- Organisational and HRD climate in BHEL: An empirical study. The Journal of Public Administration, 43(2): 209–16
- Purang, Pooja (2008). Dimensions of HRD climate enhancing organisational commitment in Indian organizations. Indian Journal of Industrial Relations, 43(4): 528–46.

- Solkhe, A., Chaudhary, N. (2011), HRD climate and job satisfaction: An empirical investigation. *International Journal of Computing and Business Research*, 2(2)
- Vijaya, B. (2007). A study on HRD climate with special reference to Public Sector Cement Corporation. *IUP Journal of Management Research*
- Bais, Singh, Santosh, "Human Resource Development (HRD) In Insurance Sector (A Study with Special Reference to Life Insurance Corporation of (LIC) India)", *EXCEL International Journal of Multidisciplinary Management Studies*, Vol.1 Issue 3, 2011, pp.196-227
- Ashutosh Muduli, (2015) "High performance work system, HRD climate and organisational performance: an empirical study", *European Journal of Training and Development*, Vol. 39 Issue: 3, pp.239-257, <https://doi.org/10.1108/EJTD-02-2014-0022>

---

## **Cyber Crime & Repercussion of Demonetization: An Analytical Study**

**Ms. SUDHA MISHRA\***

### **Abstract**

Change is the rule of nature therefore day by day world is changing and the persons of society are witnessing it along with New Technology. The new technology has created new distinguished criminal activities. After the introduction of Computer and Internet, another dangerous type of crime occurs in the whole world which is known as **Cyber Crime**. Advance technology makes person dependent on internet for all their necessities. These crimes are of many types that important ones are hacking, phishing, credit card frauds, illegal downloading, piracy industrial espionage, child pornography, scams, cyber terrorism and virus attacks. A report of **National Crime Record Bureau (NCRB)** reflects that 6% cyber crime has been increased in India in the year 2016 as compared to 2015. The total number of cases recorded in 2016, were 50,362 while more than 27,000 cases have been registered till July, 2017. Every state is facing criminal activities related to cyber world but Pune has recorded maximum number of incidents as a city whereas Uttar Pradesh has maximum number of cases in order to state. **Indian Prime Minister Mr. Narendra Modi wants to make India cashless and Digital** but illegal cyber activities are obstruction in this context. Therefore Mr. Modi's anxiety is seen in the conference of DGPs & IGPs on Jan, 2018. This paper is an attempt to analyze the problem related to cyber world and its repercussions on public.

**Keywords:**Cyber crime, Hacking, Fraud, Identity Theft, Crime rate, Demonetization.

### **Introduction:**

The Human feels dependent in modern era with Advance Technology. Human expands many hours on internet and fulfill all daily necessities through it. Internet also makes the platform to right to use to everything on sitting at one state. Person can do online most of things such as online studying, online jobs, gaming, activities on social networking site, storing data and every possible act that a person can think and do. Internet and its benefits also give the concept of cyber crime because there are so many minds in the world that they misuse this magnificent technology. Before few years, the awareness about cyber crime doesn't occur in the peoples. Cyber crime is a new class of crime that is increasing day to day with the far-reaching use of internet. Cyber crime is a combustible issue for all countries recently because most of the data is transferred or exchanges through net even governmental data. The cyber crime incidence is also increasing in India day by day like other countries. Therefore Indian Prime Minister Mr. Narendra Bhai Modi has shown his concern about cyber crime in the annual conference of DGPs & IGPs at the BSF Academy, Tekanpur, and Madhy Pradesh. He said, cyber security issues should be dealt with immediately and should receive highest priority. This statement pose, the breakage of cyber securities is the big problem for persons, corporate society, financial institutions and

---

\*Research Scholar, Faculty of Social Science, Dept. of Sociology & Political Science Dayal Bagh Educational Institute ,(Deemed University) AGRA. U.P.

administrative systems too. In the earlier era the most affected people were from U.S.A but in 21<sup>st</sup> century there is no state in the world which is not affected by cyber crime.

### **Journey of Computer & Internet:**

Computer was invented in 1822 by Charles Babbage that was the first automatic computing machine only; While Alan Turing gave the idea which became the foundation of modern computer in 1936. With this idea the journey of a computer started and finally IBM introduced a Commercial computer in 1953. Ed Roberts introduced the term 'Personal computer' in 1975 and in the end of this year laptop or portable computer also came in the market. Apart from computer, Internet also came in late 1960s with the creation of ARPANET (Advanced Research Projects Agency Network). ARPANET used bulk switching to permit multiple computers to communicate on a single network. Technology transformed in the 1970s after developed Internet Protocol by Robert Kahn and Vinton Cerf (Internet Protocol- a communication model that set standards for how data could be reached on multiple networks). In this context Tim Berners Lee invented World Wide Web in 1990. The web helps to popularize the internet in between the public and access to information & knowledge on every topic in the daily life. The illegal activity to use computer with internet is known as Cyber Crime.

### **Concept of Cyber Crime**

Cyber Crime is a vast term that is used to define criminal activity in which computer or computer network is a tool, a target or a place of criminal activity and comprises everything from electronic cracking to denial of service attacks. Cyber Crime or Computer oriented crime is crime that involves a computer and a network. Cyber Crime can be defined as, "Offences that are committed against individual or groups of individuals with a criminal motive to intentionally harm the reputation of the victim or cause physical or mental harm or loss to the victim directly or indirectly, using telecommunication networks such as internet and mobile phones". In other words, Cyber crime can defined as, "The unlawful acts where the computer is used either as tool or a target or both". Debarati Halder and K. Jaishankar define cyber crime from the perspective of gender, 'Cyber crime against women' as, "Crimes targeted against women with a motive to intentionally harm the victim psychologically and physically, using modern network i.e. internet & mobile phones". Cyber criminal threatens person, groups or a nation to break financial and security issues. Michel Aaron Dennis speaks about cyber crime, "Cyber crime, also called computer crime, the use of a computer as an instrument to further illegal ends, such as committing fraud, trafficking in child pornography and intellectual property, stealing identities, or violating privacy".

### **Some offensive Activities**

Cyber crime can be categorized in to two manners- 1) such type of crime when the **computer is target**, like-hacking, virus attacks, denial of services etc. Technical knowledge about computer, internet and other programs is necessary for a criminal 2) such type of crime when **computer is used as a tool and individual is main target**, like- credit card fraud, child pornography, cyber terrorism etc. The criminals gain the profit of human weaknesses.

- **Hacking** - Hacking means illegal intrusion into a computer system or network. Every illegal activity towards breaking into a computer/ network is hacking. Some criminals/hackers use already made computer programs to attacking the targeted computer/system. Some hackers hack the computer for personal interest e.g. stealing

the credit card information to get the money for personal purposes, transferring the money into own account from different bank accounts. In India so much people were faced this problem after demonetization and before it also.

- **Web Hacking** - Web hacking means forcefully taking the control of other person's website. In this type of crime, website's owner loses control over his/her website and its other contents. Hackers run this website in own manner however they want to run.
- **Child Pornography** - Most of cyber criminals use internet as a medium to sexually abuse children. The children are easily available target to allure. There is every family has computer system and internet connection for daily needs. Children also need internet for complete their daily home assignments and so on. Initially criminals give greed to children and gain his/her faith and then provide illegal sexual contents. Criminals pose to teenagers and child that here is better opportunity for their future and then start exploitation of children.
- **Virus Attacks** - Virus infects the data of a computer either by changing or completely deleting it. Though viruses are the programs that have strength to destroy or corrupt other programs and make it selves other copies and again spread into other programs.
- **Cyber Stalking**- In general terms stalking means, "repeated actions of harassment against victim". In this type of crime, criminals follow the victim's activities, leave a written message, make phone calls to threaten or harass, smash up victim's property even can kill victim's pet. The criminals control over the victim life either by online or offline.
- **Software Piracy**- This is a copyright violation activity. Software piracy means illegal copying of a program or making dummy and sending this dummy product instead of original.
- **Phishing** - Phishing is an activity to stealing the identity and personal information of a victim. Phishers send an email by untruthfully manner to victim to gaining some information user such as, credit card, bank account no, unique identity no.etc. Phishers provide a link to user as entitled financial institution members, the moment user go to that link and update information, the fraud has been occurred.
- **Online Gambling**- There are millions of websites available on the internet and most of them are hosted from abroad. Actually money laundering game is of back side. The cases of HAWALA and money laundering have been reported.
- **Salami Attacks** - This is a crime of commission of finance. The criminal cut a little amount of money from victims money therefore victims don't notice, e.g. a person introduce a such program in bank's server that cut very few amount like Rs.5/10/ per month from stored accounts on that bank and this little amount remains unnoticed. In this way criminal earn a plenty of money.
- **Denial of Service Attacks** - This is also known as Distributed Denial of Service (DDoS). In this type of crime, the inbox of any account has filled with spam mails and the network has crashed by flooding it and depriving his authority to access.



- **Email Spoofing** - Email spoofing refers to email that commenced from one source but indeed that email has been sent by another source that was fake source.
- **Forgery** - Forgers make counterfeit currency notes, postage, stamp papers, mark-sheets etc. with the help of high quality computer, printer and scanners.
- **Squatting** - Cyber squatting refers to act of registering a domain name and selling it for fate.
- **Cyber Terrorism** - Cyber crime can be defined as a terrorist attack through the use of computer resources (Parker, 1983). In this attack, most of authorized and legalized institutions are targeted like some institutions are military, power plants, air traffic control, banks, telecommunication networks and others such as police, medical, fire & rescue systems etc. At present time cyber terrorism is a top notch option for modern terrorists. A cyber terrorist is that person who intimidates government or an organization to advance own political or social purposes by attack on that computer where information is stored.
- **Cyber Extortion** - When a website, e-mail or computer system is targeted through repeated denial of services or other sources by hackers, cyber extortion is then occurred. Hackers demand to money against returning the services or stopping the attacks. Now a day's cyber extortion cases are increasing to attack corporate websites and networks. According to FBI (Federal Bureau of Investigation), more than 20 cases are reported each month to FBI and many others are unreported.
- **Ransom Attack** - Its baleful crime that works against hospitals, schools, state & local governments, small & large businesses, law enforcement agencies etc. that encrypts or locks digital files and demands ransom against release them. In the ransomware attack, a victim opens either email or attachment that appears legitimate but it actually contains malicious ransom code, when that person clicks on it that time he is moved to a website, contaminate his computer and his data with malicious software. The ransom attack was occurred in May, 2017 that time 74 countries had logged complaint against ransom ware cyber crime.

### **What Cyber Laws say**

The parliament of India has enacted Information Technology (IT) Act, 2000 with objectives to make enabling environment for use of internet. The Indian Penal Code, 1860 has been also amended to protect from cyber crime. The various activities related to cyber world that have been made crime to punishable under the IT Act and IPC are below-

#### **1- Cyber Crime under the IT Act;**

- Denial of services or un-authorized access to protected system,
- Hacking with computer system and data alteration,
- Tempering with computer source documents,
- Publishing obscene information,
- Publishing false digital sign certificates.

#### **2- Cyber crime under IPC;**

- Sending threatening messages by email,
  - Sending slanderous messages by email,
  - Email spoofing,
  - Email abuse,
  - Web hijacking,
  - Counterfeit websites, cyber fraud.
- 3- Cyber crime under the Special Acts;
- Online sales of Drugs under Narcotics Drugs and Psychotropic Substances Act,
  - Online sales of Arms Act.

There are also cyber cell to protect from criminals, have been situated in major cities-

- Cyber crime investigation cell (New Delhi)
- Cyber crime investigation cell (Mumbai)
- Cyber crime police station, Hyderabad city police
- Cyber crime cell (Rajasthan)
- Cyber crime police station, CID, Hyderabad

Aforementioned provisions, provided by laws and government to save the documents of people from cyber crime and to make the weather of internet save.

### **Look over the Cyber Crime data of India**

Symantec Corp, this is a software security firm has released a report in 2016, refers that India was got the position of 3<sup>rd</sup> worldwide after China and U.S.A. as a source of malicious activity in 2005.

**Malicious Activity By Source: Global Ranking**

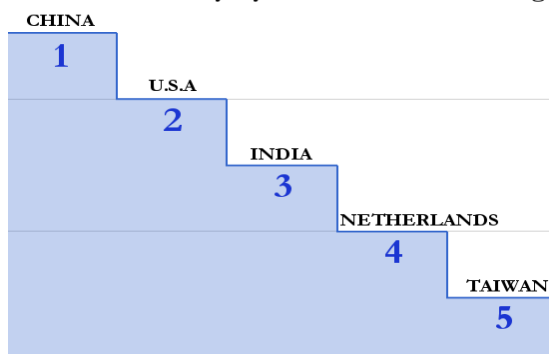

(Source: Symantec Corp)

Indian Computer Emergency Response Team (CERT), reported one case in every 10 minutes in the first half year of 2017 that is higher as compare to 2016 in every 12 minutes. Total number of cyber crime cases was reported 27,482 in between January to June, 2017 (Chetan Kumar, July, 2017).

According to National Crime Records Bureau (NCRB), cyber crime have reported to increased 19 times in India over the last 10 years 2005 to 2014, from 481 in 2005 to 9,622 in 2014. Arrestings of suspected also has increased 9 times in same duration from 569 to 5752. National Crime Record Bureau (NCRB) released annual report in 2017 on cyber crime that cyber crime cases has increased in 2016 as compare to 2015 from 11,574 to 12,317. This is 6% rise as compared to previous year. Hacking and obscene publication

were the main crime under the IT Act and most of arrested criminals were age group of 18 to 30 years.

YEAR	CASES REPORTED
2016	12,317
2015	11,574
2014	9622
2013	5693
2012	3477
2011	2213
2010	1322

According to NCRB Uttar Pradesh is on top with the highest no. of cyber cases 2,639, 21% of the total, followed by Maharashtra with 2,380 cases, 19.3% of the total, Karnataka with 1,101 cases or 8.9 % of the total, Telangana with 703 cases and then Rajasthan with 697 cases.

S.No.	States	Recorded Cases
1	Uttar Pradesh	2,639
2	Maharashtra	2,380
3	Karnataka	1,101
4	Telangana	703
5	Rajasthan	679

(Source- NCRB)

According to a Lok Sabha reply dated May 4, 2016 that more than 13,000 incidents has recorded related to cyber security, 13,851 websites were hacked where as more than 8,000 cases were recorded of spam violation till May, 2016. Maximum number of spam violations cases (85,659) were registered in 2014 and highest number of web hacking (32,323) were also occurred in same year while high number of cyber security cases was recorded in 2015. See below table. Cyber security crime such as phishing, intrusion of website, denial of services, malicious code etc. increased 76 % over the last five year from 28,127 in 2011 to 49,455 in 2015.

Year	Cyber security incidents	Web hacking	Spam
2016	13,851	13,851	8,056
2015	49,455	27,025	61,628
2014	44,679	32,323	85,659
2013	41,319	28,481	54,677
2012	36,924	27,605	8,150
2011	28,127	21,700	2,480

(Lok Sabha reply, May4, 2016)

### Repercussion of Demonetization

Cyberfrauds rise after demonetization. More than 27,000 cybercrime cases were recorded in the first half of 2017 whereas the figure was 50,362 in 2016, according to information & technology ministry. So many statements have come by many experts and authorized persons. Some are given here- **Pavan Duggal**, a cyber law expert and Supreme Court

advocate, stated that “Following demonetization many people were forced to take to online payments to meet their daily needs. Mobile wallets like have witnessed a spike in their users base. Post demonetization of the Rs.500 & 1000 notes, a majority of banks, mobile applications and e-wallets have been targeted by scamsters.” He said again,”Cyber crime has grown to an alarming extent since note ban.” In between the demonetization, “the rate of cyber crimes that was low before demonetization suddenly rising and after December 12, 2016, cyber fraud cases have witnessed a steady increase,” said cyber crime cops. **Raghuveer**, ACP, cyber crime cell, said that “Now we are getting at least four cases of credit or debit card theft every week. Apart from these cases, we are also getting One-Time Password (OTP) fraud as well.” A warning comes from ASSOCHAM, in a report in October, 2016, said, “The number of mobile frauds is expected to grow by 65% by 2017. Credit and debit cards frauds cases have topped the charts of cyber crime and increased 6 times during the last three years.”

F-Secure, a security software firm has discussed that “Post- demonetization, India is expected to be a key target for cyber criminals using malware to attack point-of-sales (POS) device and mobile wallets this year. The increasing number of attacks, especially on android device is not a hidden fact. The situation is worrisome in India, when we take into account the kind of increase seen in the volume of online transactions in the last few weeks.”

NCRB was released the data after note ban on July, 2017, reflects that 27,482 cases were registered related to cyber security till July, 2017 while 50,362 incidents ( Digital transaction, hacking etc.) were occurred in 2016, 49,455 in 2015 and 44,679 in 2014. Beside this Pune has registered highest complaints (3,350) against cyber fraud till July, 2017 than the entire 2016, followed by Gurugram with 1,900 cases.

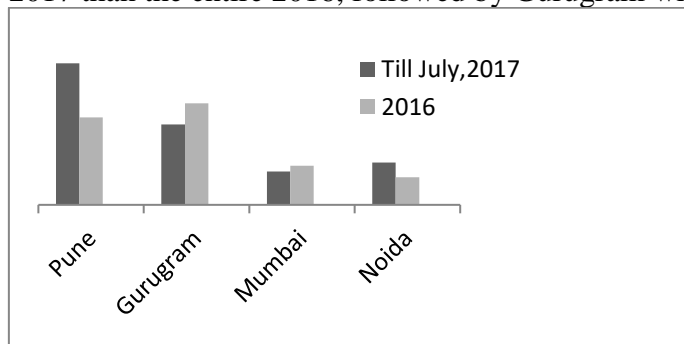

Some places are identified as cybercrime hot spot such as Tikamgarh in Madhya Pradesh, Jamtara in Jharkhand and Katrisarai in Bihar. After analyzing all the data on cyber crime, it has proven that cyber crime has increased after demonetization.

Besides all thing researcher also conducted a study in between Dec, 2017 & Jan, 2018 at Kamla Nagar in Agra city. This is an elite area of city and educated persons live here and most of them are using the key of digital payment. Nearly 50 persons have choosed as research units, most of them are of 20-35 year old humans and they are from both sexes, i.e. male and female. 22% respondents deal all works through cheques because they have various kinds of business and pay to all taxes so they don't have any issue to transaction with white money. Many governmental organizations want to fee by challan therefore 12 % respondents pay for official works through challan. 24% respondents transfer the money by paytm. Paytm has proven essential app for money transfer after demonetization. BHIM is a money transfer app and alternate of paytm had launched by Mr. Narendra Modi on Dec

30, 2016. It has advance and secured features 10% respondents use BHIM App, while 14 % respondents deal with cash. Forcibly they took to help with other source for sometime in the duration of note ban but while the money flow increased in the market again they started to do with cash.

<i>Details of Queries</i>	<i>Frequency</i>	<i>Percentage</i>
<i>Age Group</i>	<i>20-35</i>	<i>100</i>
<i>Dealing with Cheque</i>	<i>11</i>	<i>22</i>
<i>Challan</i>	<i>6</i>	<i>12</i>
<i>Paytm</i>	<i>15</i>	<i>30</i>
<i>BHIM</i>	<i>5</i>	<i>10</i>
<i>Cash</i>	<i>7</i>	<i>14</i>
<i>ATM Fraud victim</i>	<i>4</i>	<i>08</i>
<i>Debit/Credit card victim</i>	<i>3</i>	<i>06</i>
<i>Hacking victim</i>	<i>2</i>	<i>04</i>
<i>Denial of services</i>	<i>1</i>	<i>02</i>
<i>Child Pornography</i>	<i>-</i>	<i>-</i>
<i>Cyber Stalking</i>	<i>4</i>	<i>07</i>
<i>Phishing</i>	<i>3</i>	<i>06</i>
<i>Online Gambling</i>	<i>1</i>	<i>02</i>
<i>Virus Attacks</i>	<i>8</i>	<i>16</i>
<i>Forgery</i>	<i>6</i>	<i>12</i>
<i>Antivirus</i>	<i>31</i>	<i>62</i>
<i>Update anti-virus time to time</i>	<i>17</i>	<i>34</i>
<i>Installed Firewall</i>	<i>11</i>	<i>22</i>
<i>Update on</i>	<i>08</i>	<i>16</i>
<i>Safe Online Surfing</i>	<i>7</i>	<i>14</i>
<i>Operating system Up to date</i>	<i>10</i>	<i>20</i>

There are some incidents that discussed to research units by which the actual picture of link with cyber world comes front of us. 04 respondents are victim of ATM fraud, 02 respondents are victim of hacking, while one respondent is victim by unauthorized access to their system, cyber stalking crime has faced by 04 respondents, phishing by 3 respondents, online gambling by one respondent and forgery by 6 respondents have faced. While researcher wants to know about knowledge of respondents on cyber crime, the replies as- 62 % respondents installed antivirus software on their computer but most of them don't concern to update the anti-virus on expiring and installing new one. 22 % respondents know about firewall and installed it but only 16 % respondents activated it on system because when this software is on, on the system the other pirated software will be caught and most of them use pirated software due to original software which is expensive. Many persons do online surfing but really they don't know how can surf safely. The rate of awareness about cyber crime obtained less. This is the true color of society's awareness on cyber world and crimes related to it.

### **Discussion**

Life can't run smoothly without internet. Now a day anyone can image the life without net, we can say that life without colors so World Wide Web (www) is the best invention of this century by Tim Berner Lee. But some abnormal minds misuse this technology for their

greedy. This research paper has mentioned various kind of cyber crime such as hacking, web hacking, ransom attack, virus attacks, sabotage, software piracy, email spoofing, spam violation, cyber extortion, cyber terrorism etc. This paper has also told about what activities compass under IT Act and what activities compass under Indian Penal Code and Special laws. Here are giving some precautions to safe data on computer and by following these steps can secure personal information & properties too-

- ✓ **To install or update Antivirus Software-** Anti-virus software is designed to safe from malicious software attack, if it is detect on the computer, it works against malicious program and remove it. Anti- virus software updates time to time automatically or by purchase either online or market.
- ✓ **To keep operating system up to date-** Everyone should install computer updates to ensure your computer can protect your data from latest preventions.
- ✓ **Keep firewall turned on** – A firewall helps to protect the computer form hacker's attack and safe the data or personal information that stored on computer. Especially it is recommended for single computer while hardware routers hardly available for multiple networks.
- ✓ **Antispyware Technology-** Spyware is software that is installed on computer stealthily. Spyware software steals the personal data without user consent or reproduces unnecessary ads on the web browser. Some pricey operating system give the facility of antispyware technology but antispyware that avail on internet most of them are fake or contain spyware or other malicious code so buy it from reliable source.
- ✓ **Beware on downloading** – Haphazardly downloading email attachment or open every link can be risky or break off the service. Everyone should not open every attachment comes from that source whose you don't know.
- ✓ **Safe online surfing** – Only surf appropriate things what you need actual. Unsafe surfing can circumvent any computer or breakage the service.
- ✓ Every corporative firm should reserve some post for that persons who has adequate knowledge about cyber world related to crime and can take previous steps before attacks.
- ✓ The police department of our country is not well trained and doesn't know how to deal with a cyber crime in better way. Some experienced and expert persons should appoint for these crimes in the police department because most of victims initially go to police instead of cyber cell.
- ✓ **Awareness** – Anyone who uses the internet for any reason can be succumb of such attack therefore anyone should aware how one is being protected while online.

### **Conclusion**

One day that Country will rule on entire World who has latest Technology with high security. In the modern context internet is that medium by which anyone can direct to others e.g. last presidential election in the U.S.A. opposition alleged that Russia is directed to their country election that's why Donald Trump had won the president crown. It means any agency can direct to anything with the help of internet. Internet is beneficial to all, anybody can do everything at one state but the misuse of this magnificent technology is



defaming this. Everyone should beware and should has knowledge about how can use internet safely.

### **Acknowledgement**



I am thankful to Dr. Priyanka Singh, Assistant Professor and my supervisor at Dayal Bagh Educational Institute, Agra, U.P. Her support gives me inspiration and courage to write research paper and also capacity of analyzing the appropriate figures. I am also thankful to Prof. Nitish Dubey (Professor at D.A.V. College, Kanpur University) & Mr. M.K.Singh sir (Director of Howard Institute, Agra) who corrects me time to time .Without their inspiration, support and help I am not capable to write. I am also thankful to those article writers who give me the platform for this paper.

### **References**

- R.P.Kaur (2013). Statics of Cyber Crime in India: An Overview. International Journal of Engineering and Computer Science. Vol-2, Issue-8. Page No.-2555-59.
- Cyber Crime. From- <https://en.wikipedia.org/wiki/cybercrime>.
- What we investigate: cyber crime. From- <https://www.fbi.gov/investigate/cyber>
- Learn about cyber crime. From- <https://www.acorn.org.au/learn-about-cyber-crime>.
- PM Modi asks top police officials to deal with cyber crime on priority. From- <https://www.ndtv.com/india-news/pm-modi-ask-top-police-officials-to-deal-with-cyber-crime-on-priority-1797458>.
- Dennis, Michael Aaron (2017). Cyber Crime. From- <https://www.britannica.com/topic/cybercrime/spam-steganography-and-e-mail-hacking>.
- When was the First computer invented? From- <https://www.computerhope.com/issue/ch000984.htm>.
- Who invented the internet? Ask history. From- [www.history.com/news/ask-history/who-invented-the-internet](http://www.history.com/news/ask-history/who-invented-the-internet).
- Cyber Crime rate in India. From- <https://www.youthkiawaaz.com/2016/06/cyber-crime-rate-in-india>.
- Cyber Crime in India every 10 minutes increases. From- <https://timesofindia.indiatimes.com/india/one-cybercrime-in-india-every-10-minutes/articleshow/59707605.cms>
- National Crime Record Bureau released data on cyber crime. From- [www.news18.com/news/india/ncrb-release-data-on-cybercrime-rise-experts-fear-figure-do-not-reveal-real-picture-1597555.html](http://www.news18.com/news/india/ncrb-release-data-on-cybercrime-rise-experts-fear-figure-do-not-reveal-real-picture-1597555.html)

- Cyber Crime cases shoot up post demonetization. From- <https://cio.economicstimes.indiatimes.com/news/digital-security/cyber-ccrime-cases-shoot-up-post-demonetization/56133910>.
- India has become key target for cybercrime after demonetization. From- [www.bgr.in/news/india-has-become-key-target-for-cybercrime-after-demonetization-f-secure-report/](http://www.bgr.in/news/india-has-become-key-target-for-cybercrime-after-demonetization-f-secure-report/)
- Government pushes for digitized cashless economy cyber frauds rise. From- <https://www.hindustantimes.com/india-news/as-government-pushes-for-digitised-cashless-economy-cyber-frauds-rise/story-61HRONOMuuoi652Q8FOuk.html>.

## **Customer Preferences on Retail Outlets in Chennai City**

**Mrs. D. Jesura Pauline\***

**Dr. V. Darling Selvi\*\***

### **Abstract**

The Indian retail industry has emerged as one of the most dynamic and fast-paced industries due to the entry of several new players. It covers diverse products such as textiles, food and grocery, consumer durables, footwear, books and music, financial services and leisure. In short a retailer is a person responsible for making available the desired product in desired size at desired times to a customer. India is the world's fifth-largest global destination in the retail space. Indian Retail Industry has immense potential as India has the second largest population with affluent middle class, rapid urbanisation and solid growth of internet. A study which has been conducted among 300 sample respondents who have the experience of visiting different retail outlets in Chennai City is presented in the paper. The researcher has applied t test, Factor analysis and correlation analysis to interpret the results. It is concluded from the study that sample respondents do prefer shopping outlets mainly due to free entry and exit and offers on price. It is further concluded that sample respondents do prefer retail outlets with display of merchandise with fair return policy and comfortable environment and return policy with prompt delivery services. The factors derived from the analysis regarding the selection of retail outlet are Safety and Security, Services and Schedules, Offers and low Price and Recreation. It is understood that the main aim of the people preferring retail outlets is the result of safety and services. By Understanding the changing consumers' behavior, the retail markets can devise strategies to suit their needs and to attract more customers. This will broaden the scope of more retail outlets not only in the urban area but will also flourish in the rural areas too.

**Key words:** Ambience, Customer, Layout, Purchase Decision, Retail Outlets, Selection

### **Introduction**

The Indian customer is younger, more tech savvy, willing to experiment, demanding and short on patience; but, on the other hand, willing to spend and patronize a brand if treated well and given a good deal. Store operations in general have evolved significantly in terms of internal processes, systems and technology usage. However, Indian retailers have a long way to go in terms of customer experience management, people management, streamlining internal processes and technology adoption. With the market crowded with many similar brands, retailers are coming around to the view that service is the true differentiator. They believe that customers will develop trust through right advice and exceptional service which will be reflected through increased loyalty. Retailing in India is evolving rapidly, with consumer spending growing by unprecedented rates and with increasing no of global players investing in this sector. Organized retail in India is undergoing a metamorphosis

---

\* Assistant Professor of Commerce, Research Department in Commerce, TDNMS College, Kallikulam, Manonmaniam Sundaranar university, Tirunelveli – 12

\*\* Assistant Professor of Commerce, Research Department in Commerce, Rani Anna Government College for Women, Tirunelveli-8, Manonmaniam Sundaranar university, Tirunelveli – 12

and is expected to scale up to meet global standards over the next five years. The Indian retail industry has emerged as one of the most dynamic and fast-paced industries due to the entry of several new players. It covers diverse products such as textiles, food and grocery, consumer durables, footwear, books and music, financial services and leisure. In short a retailer is a person responsible for making available the desired product in desired size at desired times to a customer. That is its value proposition to customers (Rathod, 2011). It accounts for over 10 per cent of the country's Gross Domestic Product (GDP) and around 8 per cent of the employment. India is the world's fifth-largest global destination in the retail space. Indian Retail Industry has immense potential as India has the second largest population with affluent middle class, rapid urbanisation and solid growth of internet.

- India has occupied a remarkable position in global retail rankings; the country has high market potential, low economic risk and moderate political risk
- India is expected to become the world's third-largest consumer economy, reaching US\$ 400 billion in consumption by 2025, according to a study by Boston Consulting Group
- India is ranked first in the Global Retail Development Index 2017, backed by rising middle class and rapidly growing consumer spending
- India's retail market witnessed investments worth US\$800 million by Private Equity (PE) firms and wealth funds in 2017.
- Department of Industrial Policy and Promotion (DIPP) approved three foreign direct investments (FDI), Mountain Trail Food, Kohler India Corporation, and Merlin Entertainments India in the single brand retail sector.

A study which has been conducted among 300 sample respondents who have the experience of visiting different retail outlets in Chennai City has been presented and analysed in the following tables.

#### **Ambience and layout of the retail outlets**

A store's layout is one of the key strategies in its success--therefore, a lot of time, effort and manpower go into its design. Retailers use layout to influence customer's behavior by designing the store's flow, merchandise placement and ambience. The flow of a store's layout determines how customers shop. The longer a customer is in a store, the more likely she is to buy--therefore, the goal is to keep her shopping longer. The layout can organize product categories together so that customers find different items they are looking for in one location. Equally as important is the layout's ability to keep complementary products or similar brands in proximity so that a customer will be more inclined to buy products connected to the one they are shopping for. Grouping together designers that cater to a similar customer or merchandising is a way to bring additional cross-category or cross-brand sales. The store layout design can determine what emotions are evoked in the shopping experience. Factors such as merchandise arrangements, fixture colors and aisle space affect whether a customer likes, and therefore frequents, a store. The successful layout of a store depends on whether it has a clear and legible concept; i.e. one can easily find products and find them the first time during every trip. The various labels, information posters and signs can contribute to the concept of the store layout design in creating a favourable and attractive store environment (Spies et al., 1997). The opinion of the sample respondents in this respect was collected and has been presented and analysed in the following tables.

**Table 1 t test for the opinion of ambience and layout of the favorite retail outlets**

Statements	t	Sig. (2-tailed)	Mean	95% Confidence Interval	
				Lower	Upper
Regularly offers some products at a discounted price and at everyday low price	42.65	0.000	1.54	1.6788	1.8412
Holds exciting & participative special events and shows	37.98	0.000	1.65	1.5677	1.739
Allows me to view a wide assortment of related items in a short period of time	37.80	0.000	1.78	1.7979	1.9954
Has prompt help or knowledgeable, friendly courteous and available sales persons / employees who approach me only when needed	35.52	0.000	1.76	1.8136	2.0264
Enable me to get in, get what I want and get out	33.87	0.000	1.92	1.4474	1.6259
Is a good place to see and follow trends that are coming for the new season	32.43	0.000	1.95	1.8285	2.0648
Has attractive interior walls and floor colours	32.10	0.000	1.90	1.674	1.8927

**Source: Primary Survey**

As per t test it is noted that the statement Regularly offers some products at a discounted price and at everyday low price ranks first with a score of 42.65 which is followed by the statements Holds exciting & participative special events and shows (37.98), Allows me to view a wide assortment of related items in a short period of time (37.80), Has prompt help or knowledgeable, friendly courteous and available sales persons / employees who approach me only when needed (35.52), Enable me to get in, get what I want and get out (33.87), Is a good place to see and follow trends that are coming for the new season (32.43) and Has attractive interior walls and floor colours (32.10). The mean value is high for the statement the malls are good place to see and follow trends that are coming for the new season (1.95) and is low for the statement “Regularly offers some products at a discounted price and at everyday low price” (1.54). All the selected statements are statistically significant as the p values are lesser than 0.05.

**Table 2 Correlations for the opinion of ambience and layout of the favorite retail outlets**

Statements		Free entry and exit	Special events & shows	Attractive interiors	Offers on price	Courteous employees	Seasonal products	Assorted items
Free entry and exit	r	1.00						
	Sig.	.						
Special events and shows	r	-.011	1.00					
	Sig.	.850	.					
Attractive interiors	r	.052	.048	1.00				
	Sig.	.366	.407	.				
Offers on price	r	.200**	-.135*	-.130*	1.00			
	Sig.	.001	.020	.025	.			
Courteous employees	r	.016	-.090	.088	.169**	1.00		
	Sig.	.778	.119	.128	.003	.		
Seasonal products	r	-.130*	.106	.003	-.067	-.054	1.00	
	Sig.	.024	.065	.962	.249	.349	.	
Assorted items	r	.016	-.118*	.011	.112	-.036	.026	1.00
	Sig.	.776	.042	.844	.053	.537	.653	.

**Source: Derived**

From the correlation it is noted that the variable free entry and exit has significant positive relationship with offers on price and significant negative relationship with seasonal products, the variable special events and shows has significant negative relationship with offers on price and assorted items, the variable attractive interiors has significant negative relationship with offers on price and offers on price has significant positive relationship with Courteous employees. Hence it is concluded that sample respondents do prefer shopping outlets mainly due to free entry and exit and offers on price.

**Purchase Decision**

The traditional shopping choice behavior of consumers was related to need recognition, because a consumer become aware of his need and based on which he/she wants to purchase a product. Once the need has been recognized, then he moves on to search for information about the product and evaluates the alternatives available before finally makes a decision to purchase the product. The retail sector in India is witnessing a huge revamping exercise as traditional markets make way for new formats such as departmental stores, hypermarkets, supermarkets and specialty stores. Consumer buying behavior refers to the buying behavior of the ultimate consumer. Consumer behavior is the understanding of how consumers make decision to use their resources such as time money and effort for buying using and disposing goods and services .the behavior of humans as consumers is complex. Marketers understanding of the drivers of consumers buying behavior will help them to service their customer effectively and efficiently and attract new customers. Gomathi et al. (2013) studied the consumer attitude towards departmental stores of organized retail outlet in Erode city. The preferences of the consumers clearly indicate the importance of advertisement in influencing their purchase, the additional facilities expected, improvement expected in handling defective goods and many more. The following tables exhibit the opinion of the sample respondents in connection with the factors influencing the purchase decision.



**Table 3 Factors influencing Purchase Decision**

Statements	t	Sig. (2-tailed)	Mean	95% Confidence Interval	
				Lower	Upper
Feeling that the physical environment is comfortable	59.71	0.00	1.75	1.69	1.80
Being able to find high quality products	49.44	0.00	1.86	1.79	1.94
Being able to find out about new, latest and unique products	49.14	0.00	1.97	1.89	2.05
Finding nice display of merchandise	46.34	0.00	1.72	1.65	1.80
Having a no hassle return policy	43.65	0.00	2.07	1.98	2.17
Having a reliable delivery service	42.32	0.00	2.10	2.00	2.19
Being able to find famous name brands	33.80	0.00	2.06	1.94	2.18
Being able to compare shops	32.31	0.00	2.25	2.11	2.38

Source: Primary Survey

As per t test it is noted that the statement Feeling that the physical environment is comfortable ranks first with a score of 59.71 which is followed by the statements Being able to find high quality products (49.44), Being able to find out about new, latest and unique products (49.14), Finding nice display of merchandise (46.34), Having a no hassle return policy (43.65), Having a reliable delivery service (42.32), Being able to find famous name brands (33.80) and Being able to compare shops (32.31). The mean value is high for the statement being able to compare shops (2.25) and is low for the statement finding nice display of merchandise (1.72). All the selected statements are statistically significant as the p values are lesser than 0.05.

**Table 4 Correlations for the opinion Factors influencing Purchase Decision**

Items	r	Popular Brands	Quality Products	Unique Products	Comparison of Shops	Merchandise Displays	Comfortable Environment	Return Policy	Delivery Service
Popular Brands	r	1.00							
	Sig.								
Quality Products	r	-.322**	1.00						
	Sig.	.000	.						
Unique Products	r	-.128*	-.122*	1.00					
	Sig.	.027	.035	.					
Comparison of Shops	r	.117*	-.143*	.172**	1.00				
	Sig.	.043	.013	.003	.				
Merchandise Display	r	-.006	.066	-.078	-.042	1.00			
	Sig.	.914	.257	.177	.464	.			
Comfortable Environment	r	-.019	-.010	.017	.089	-.238**	1.00		
	Sig.	.739	.868	.770	.124	.000	.		
Return Policy	r	-.032	.066	.042	-.028	.313**	-.173**	1.00	
	Sig.	.587	.254	.469	.624	.000	.003	.	
Delivery Service	r	-.087	.072	-.014	.108	-.040	.314**	.217**	1.00
	Sig.	.133	.213	.809	.062	.489	.000	.000	.

Source: Derived

It could be seen from the correlation analysis that the variable Popular Brands has significant positive relationship with Comparison of Shops and significant negative relationship with Quality Products and Unique Products, the variable Quality Products has significant negative relationship with Unique Products and Comparison of Shops, the variable Unique Products has significant positive relationship with Comparison of Shops, the variable Merchandise Display has significant positive relationship with Return Policy and significant negative relationship with Comfortable Environment, the variable Comfortable Environment has significant positive relationship with Delivery Service and significant negative relationship with Return Policy and the variable Return Policy has significant positive relationship with Delivery Service. Hence it is concluded that sample respondents do prefer retail outlets with display of merchandise with fair return policy and comfortable environment and return policy with prompt delivery services.

**Reasons for the selection of Retail outlets**

As the number of products and brands are increasing in the market, so are the retail outlets, and it becomes very confusing for the customer to choose the retail stores. The selecting of a retail store also involves almost the same process as selecting a brand. A retail outlet relates to a service or a product which caters to the consumer. Researchers have identified a number of factors influencing store choice. Morschett et al. (2005) summarise these to include product quality, assortment, 1-stop, price, speed and quality of service and the atmosphere of the in-store experience. They identify which attributes contribute to the store choice decision, but not why these attributes are or are not important. The survey based results are being analysed and presented as below.

**Table 5 Rotated Component Matrix for the reasons for the selection of Retail outlets**

Statements	Components			
	1	2	3	4
Lockers for Bags, Backpacks etc	<b>.817</b>	-.129	-.039	-.017
Daycare for kids / toddlers or play pen	<b>.780</b>	.131	.012	.006
Offers through special sales/exhibits/promotional events/ Concerts etc	-.141	<b>.773</b>	-.072	-.193
Offers services like gift wrapping, photo processing, courier, gift delivery etc	-.030	<b>-.720</b>	-.041	-.084
Availability of store schedule information along with customer service center	-.253	<b>-.406</b>	-.109	-.200
Offers through Mailers, Flyers, and samples	.175	.235	<b>-.688</b>	.048
Credit Cards Offers	.246	.180	<b>.626</b>	-.333
Offers on competitive/low prices	.015	.199	<b>.625</b>	.329
Free concerts, live music on weekend evenings	.003	.016	-.024	<b>.897</b>
<b>% of Variance</b>	<b>16.13</b>	<b>16.01</b>	<b>14.18</b>	<b>12.33</b>
<b>Cumulative %</b>	<b>16.13</b>	<b>32.14</b>	<b>46.32</b>	<b>58.65</b>
<b>% to total</b>	<b>28</b>	<b>27</b>	<b>24</b>	<b>21</b>

**Source: Primary Survey**

**Safety and Security:** This is an important aspect which everybody aspires of and is being essential too in this modern world. The preference of this factor depends on the statements Lockers for Bags, Backpacks etc (.817) and Daycare for kids / toddlers or play pen (.780). This factor has the variance of 16.13 which occupy 28 percent out of total.

**Services and Schedules:** Generally people need services anywhere and retail outlets are no exception to it and as such here the statements filtered are Offers through special sales/exhibits/promotional events/ Concerts etc (.773), Offers services like gift wrapping, photo processing, courier, gift delivery etc (-.720) and Availability of store schedule information along with customer service center (-.406). This factor has the variance of 16.01 which occupy 27 percent out of total.

**Offers and low Price:** Offers can be of various kinds in case of sales which are followed by the retail outlets to attract the attention of the customers. The statements filtered in this factor are Offers through Mailers, Flyers, and samples (-.688), Credit Cards Offers (.626) and Offers on competitive/low prices (.625). This factor has the variance of 14.18 which occupy 24 percent out of total.

**Recreation:** Recreation is part and parcel of human life to get relived from the routine work and stress. They can enjoy the shopping along with recreation in the retail outlets. The only statement come under this factor is free concerts, live music on weekend evenings (.897). This factor has the variance of 12.33 which occupy 21 percent out of total.

**Table 6 Component Transformation Matrix**

Components	Safety	Services	Offers	Recreation
Safety	.652	.678	.338	.032
Services	<b>.755</b>	-.620	-.208	-.035
Offers	.068	.373	-.902	.208
Recreation	-.009	-.124	.173	.977

**Source: Derived**

It is inferred from the transformation matrix that the factor Safety has relationship with Services (.678), the factor Services has relationship with Safety (.755), the factor Offers has little relationship with Services (.373), and the factor Recreation has little relationship with Offers (.173). Hence it is understood that the main aim of the people preferring retail outlets is the result of safety and services.

**Conclusion**

The correlation analysis revealed that the variable free entry and exit has significant positive relationship with offers on price and significant negative relationship with seasonal products, the variable special events and shows has significant negative relationship with offers on price and assorted items, the variable attractive interiors has significant negative relationship with offers on price and offers on price has significant positive relationship with Courteous employees. It is concluded from the study that sample respondents do prefer shopping outlets mainly due to free entry and exit and offers on price. It is further concluded that sample respondents do prefer retail outlets with display of merchandise with fair return policy and comfortable environment and return policy with prompt delivery services. The factors derived from the analysis regarding the selection of retail outlet are Safety and Security, Services and Schedules, Offers and low Price and Recreation. The factor Safety has relationship with Services (.678), the factor Services has relationship with Safety (.755), the factor Offers has little relationship with Services (.373), and the factor Recreation has little relationship with Offers (.173). Hence it is understood that the main aim of the people preferring retail outlets is the result of safety and services. By Understanding the changing consumers' behavior, the retail markets can device strategies to suit their needs and to attract more customers. This will broaden the scope of more retail outlets not only in the urban area but will also flourish in the rural areas too.

## References

1. Anand, K.S. and P.K. Sinha, 2009. Store format choice in an evolving market: role of affect, cognition and involvement. *International Review of Retail, Distribution and Consumer Research*, 19(5): 505-534.
2. Bianchi, C. (2009), "Investigating Consumer Expectations of Convenience Store Attributes in Emerging Markets: Evidence in Chile", *Journal of International Consumer Marketing* Vol:21(4), p.178
3. Gomathi R, Kishore S, Deepika R. A Study on Customer Satisfaction towards Departmental Stores in Erode City. *International Journal of Engineering and Management Research* 2013; 3(5): 38-41
4. Morschett, D., Swoboda, B., Schramm-Klein, H., (2005), "Perception of store attributes and overall attitude towards grocery retailers: The role of shopping motives", *The International Review of Retail, Distribution and Consumer Research*, 15(4), pp. 423-447
5. Rathod KL. Retailing in India: An analytic view of sunrise industry. *Excel International Journal of Multidisciplinary Studies* 2001; 1(2): 168-184.
6. Spies, K., Hesse, F. and Loesch, K. (1997), "Store atmosphere, mood and purchasing behaviour", *International Journal of Research in Marketing*, Vol. 14 No. 1, pp. 1-17

## **“Performance Improvement of VSC Based HVDC Transmission Techniques”**

**Vivek kumar Sahu\***

**Dr. Srikant Prasad\*\***

### **Abstract**

This paper deals with a new three-level Voltage Source Converter (VSC) with its dynamic control and power quality improvement for High Voltage Direct Current (HVDC) system. The proposed three-level voltage source converter (VSC) topology for HVDC system consists of two converter stations fed from two different ac systems. The active power is transferred between the stations either way. The reactive power is controlled independently in each converter station. The three-level VSC is operated at optimum dead angle which gives the harmonic performance equivalent to a two-level 24-pulse voltage source converter. Both converter stations can be operated as either a rectifier or an inverter according to their direction of active power flow. These VSC based converters are operated at Fundamental Frequency Switching (FFS) to reduce the losses in the system. A control algorithm is developed for bidirectional active power flow, independent reactive power control for both rectifier and inverter stations. The proposed converter topology is found highly suitable for high power rating systems and this results in a substantial reduction in switching losses and avoiding additional reactive power plant and filter arrangements. Simulation is carried to verify the performance of the proposed VSC topology and control method for bidirectional active power flow and their independent reactive power control.

**Index Terms** – HVDC System, Three-level Voltage Source Converter, Dead Angle, Fundamental Frequency Switching, Active Power Flow, Reactive Power Control, Power Quality, and Total Harmonic Distortion

### **I. Introduction**

At the beginning of the electricity supply industry there was a great battle between the proponents of Alternating Current and Direct Current alternatives for electricity distribution. This eventually played out as a win for AC, which has maintained its dominance for almost all domestic, industrial and commercial supplies of electricity to customer. As the size of electricity supply systems increased several major challenges for AC systems emerged.

There were major difficulties in increasing the voltage and the range of under-sea cables. Also the development of very large hydro-electric projects in areas quite remote from their load centres became an increasing challenge for AC systems to transport vast quantities of electricity over very great distances. For very large transmission schemes High Voltage Direct Current (HVDC) is both more efficient and has a greater capability than AC systems. It was recognised as early as the 1920's that there were advantages in the use of DC transmission systems for these more challenging applications. Hence the concept of

---

\*Student of MTECH Power system and Power Electronics, Department Electrical and Electronics Engg

\*\*Asst.Prof. Department Electrical and Electronics Engineering, O.P. JINDAL UNIVERSITY PUNJIPATHRA RAIGARH (C.G.)



HVDC emerged, however development was held back by the lack of a suitable technology for the valves to convert AC to DC and vice versa.

High Voltage Direct Current Technology is a most attractive transmission technology when power has to be transmitted over long distances. The first commercial HVDC transmission project has been installed in Sweden in 1954. In last half century, its application has widely increased. A total of around 70000MW of transmission capacity is transmitted around the world through 95 HVDC projects [1]. Due to the burgeoning demand for electrical power in one area and concentration of electrical generation in another area, a number of high capacity long distance HVDC systems are planned where bulk power from one region to another region is being transmitted. Advancement in power electronics is making High Voltage Direct Current Transmission Systems (HVDC) more and more attractive and reliable. Developing countries like India and China with their ambitious power capacity enhancement program are installing more HVDC systems for long distance transmission. More can be obtained from investments in complex HVDC systems if operation and maintenance personnel have deeper understanding about the functioning of these systems. Further commissioning/ maintenance errors may be minimized if the consequences of such errors are known and appreciated by the concerned personnel. Easy to comprehend, simple analytical HVDC converter model as developed in universal software Mat lab/ Simulink in this paper can prove to be very useful for operation and maintenance personnel. The model illustrates steady state operation of HVDC system converter and can be used to comprehend commutation and overlap, valve firing sequence, AC current and voltage waveforms in converter transformer & the source, and DC current including ripple. The model also helps in understanding the role and importance of AC filters.

- **Converter Station**

An HVDC converter station is a specialised type of substation which forms the terminal equipment for a high-voltage direct current (HVDC) transmission line. It converts direct current to alternating current or the reverse. In addition to the converter, the station usually contains:

1. three-phase alternating current switchgear
2. Transformers
3. Capacitors or synchronous condensers for reactive power
4. Filters for harmonic suppression
5. Direct current switchgear

- **Three-phase alternating current switch gear:-**

The three-phase alternating current switch gear of a converter station is similar to that of an AC substation. It will contain circuit breakers for over current protection of the converter transformers, isolating switches, grounding switches, and instrument transformers for control, measurement and protection. The station will also have lightning arresters for protection of the AC equipment from lightning surges on the AC system.

- **Transformer**

The converter transformers step up the voltage of the AC supply network. Using a star-to-delta connection of the transformer windings, the converter can operate with 12 pulses for each cycle in the AC supply, which eliminates numerous harmonic current components. The insulation of the transformer windings must be specially designed to withstand a large DC potential to earth. Converter transformers can be built as large as 300 megavolt-



amperes (MW) as a single unit. It is impractical to transport larger transformers, so when larger ratings are required, several individual transformers are connected together. Either two three-phase units or three single-phase units can be used. With the latter variant only one type of transformer is used, making the supply of a spare transformer more economical.

- **Converter**

The converter is normally used on a building which called valve hall. Converters using thyristors or valves are known as line commutated converters. Here thyristor-based converters are connected in series to form a thyristor valve and the converter consists of twelve thyristor valves. The thyristor valves are usually grouped in pairs or groups of four and can stand on insulators on the floor or hang from insulators from the ceiling.

- **Reactive Power**

When line commutated converters are used, the converter station will require between 40% and 60% of its power rating as reactive power. This can be provided by banks of switched capacitors or by synchronous condensers, or if a suitable power generating station is located close to the static inverter plant, the generators in the power station. The demand for reactive power can be reduced if the converter transformers have on-load tap changers with a sufficient range of taps for AC voltage control. Some of the reactive power requirement can be supplied in the harmonic filter components. Voltage sourced converters can generate or absorb reactive as well as real power, and additional reactive power equipment is generally not needed.

- **Harmonic Filter**

Harmonic filters are necessary for the elimination of the harmonic waves and for the production of the reactive power at line commutated converter stations. At 12 pulse converter Stations, only harmonic voltages or currents of the order  $12n+1$  and  $12n-1$  (on the AC side) or (on the DC side) result. Filters are tuned to the expected harmonic frequencies and consist of series combinations of capacitors and inductors. Voltage sourced converters generally produce lower intensity harmonics than line commutated converters.

- **DC equipment**

The direct current equipment often includes a coil (called a reactor) that adds inductance in series with the DC line to help smooth the direct current. The inductance typically amounts to between 0.1 H and 1 H. The smoothing reactor can have either an air-core or an iron-core. Iron-core coils look like oil-filled high voltage transformers. Air-core smoothing coils resemble, but are considerably larger than, carrier frequency choke coils in high voltage transmission lines and are supported by insulators. Air coils have the advantage of generating less acoustical noise than iron-core coils, they eliminate the potential environmental hazard of spilled oil, and they do not saturate under transient high current fault conditions. This part of the plant will also contain instruments for measurement of direct current and voltage. Special direct current filters are used to eliminate high frequency interference. Such filters are required if the transmission line will use power-line communication techniques for communication and control, or if the overhead line will run through populated areas. These filters can be passive LC filters or active filters, consisting of an amplifier coupled through transformers and protection capacitors, which gives a signal out of phase to the interference signal on the line, thereby cancelling it.

## **II. Advantages of HVDC Compared With AC**

- The AC transmission encountered both efficiency and economic problems with long

Distances, represented chiefly by the use of cables but also by overhead lines. Due to Inductive and capacitive elements, the AC cables exchange too much reactive power, Phenomena known as Ferranti effect. Putting the limit of roughly 40-100 km for AC Overheadlines.

- Furthermore, the connection between two AC systems may be impossible, due to different Frequency, instability or undesired flow scenarios. DC transmission does not suffer with charging current neither skin effect; thus it's not limited by distances and its preferred for distances higher than 40km.
- The DC has the further advantage to comply with fast power control improving the system stability. Also economic aspect has to be taken in consideration. Summing the cost of terminals and line, a break-even distance has been recognized, beyond which the DC system is cheaper than the AC one. The break-even distance lies usually between 500 and 800km. figure 2 shows the comparison of total cost over distance for AC-DC system.



**Figure 2 Comparison of Total Cost over Distance for AC and DC System**

- The PWM operates at a high frequency value, it allows a fast response to disturbances and the design of small high frequency filters. Moreover, along with IGBT, it makes VSC operation independent of the grid strength, being even able to feed a passive load or energize a dead network during a blackstart.
- The VSC doesn't require any external AC source, absorbing then less reactive power
- Q. The converter operation in 4 quadrants allows the fast control of active and reactive power independently and helps the creation of multi-terminal systems, thanks to the power flow reversal without changing the Vdc polarity.
- In case of fault, Power level of HVDC system can be controlled electronically i.e. very fast.
- HVDC has minimum audible noise, as well as minimum radio, TV interference.
- Cost of Transmission is less, since only two conductors are used for transmission.
- There is no reactive power so transmission losses are reduced.
- There is no skin effect.

### III. Inherent Problems Associated With HVDC

- **Complexity**

In contrast to AC systems, designing and operating multi-terminal HVDC systems is complex. Controlling power flow in such systems requires continuous communication

between all terminals, as power flow must be actively regulated by the control system instead of by the inherent properties of the transmission line.

- **Expensive Converter**

Converter stations needed to connect to AC power grids are very expensive. Converter substations are more complex than HVAC substations, not only in additional converting equipment, but also in more complicated control and regulating systems.

- **PowerFaults**

During short-circuits in the AC power systems close to connected HVDC substations, power faults also occur in the HVDC transmission system for the duration of the short-circuit. Inverter Substation are most affected. During short-circuits on the inverter output side, a full HVDC transmission system power fault can be caused. Power faults due to short-circuits on the rectifier input side are usually proportional to the voltage decrease.

- **RadioNoise**

The high-frequency constituents found in direct current transmission systems can cause radio noise in communications lines that are situated near the HVDC transmission line.

#### **IV. Methodology**

- **Voltage Source Converters**

A VSC has a voltage source connected on the dc side in the form of a large capacitor appropriately charged to maintain the required voltage. A constraint imposed on the circuit of a power converter is that one side needs to be inductive and another capacitive to prevent a loop consisting of voltage sources. On a VSC, the ac side has an inductance connected,

Which has two purposes: first, it stabilizes the ac current and second, it enables the control of active and reactive output power from the voltage source converter. A VSC requires self-commutating switches such as gate turn off thyristors (GTO) or insulated-gate bipolar transistors (IGBT), which has a turn-on and turn-off capability so the position and frequency of the on and off switching instants can be altered to provide a specific voltage and current waveform. The world of converters may be divided into two groups that are to be distinguished by their operational principle. One group needs an AC system to operate and called as line commutated converter. Conventional HVDC systems employ line commutated converters. The second group of converters does not need an AC system to operate and is therefore called as self-commutated converters. Depending on the design of the DC circuits this group can be further divided into current source converters and voltage source converters. A current source converter operates with a smooth DC current provided by a reactor, while a VSC operates with a smooth DC voltage provided by storage capacitor. Among the self-commutated converters it is especially the VSC that has big history in the lower power range for industrial drive applications.

- **VSC-HVDC Transmission**

The use of HVDC technology has traditionally been limited to point-to-point interconnections. However, there is an increasing interest of more inter connection points constituting to a dc grid. This is because of technological advances in power electronics and VSC system but also due to grid integration challenges from remotely located generation sites. Since there are two types of HVDC conversion methods, two types of dc grids are possible. However, this work will only consider the VSC type.

**V.Simulation Circuit for HVDC Transmission**

The circuit diagram of figure 5.1 shows the simulation circuit diagram of HVDC Transmission.

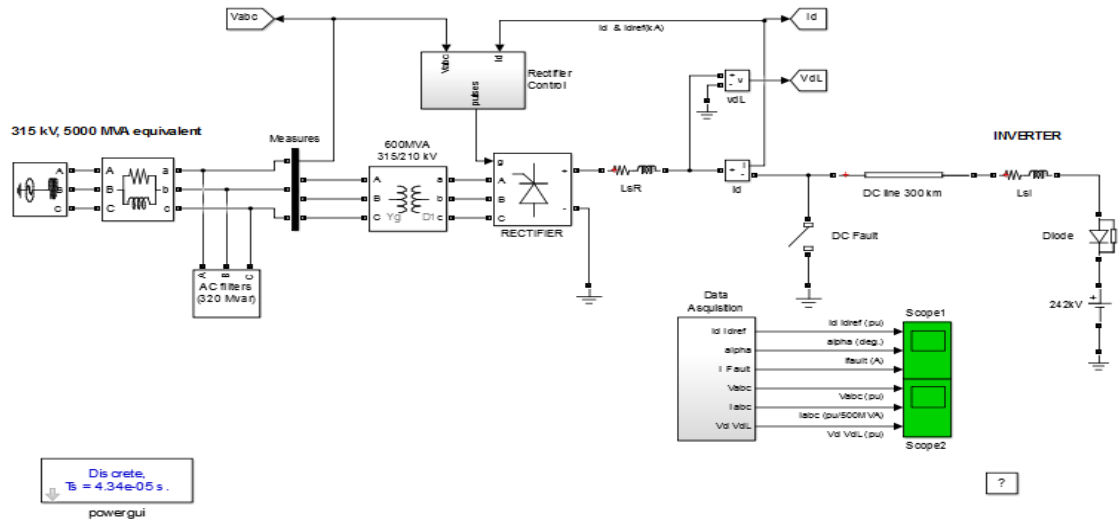

**Figure 5.1 Simulation model of HVDC Transmission 1.**

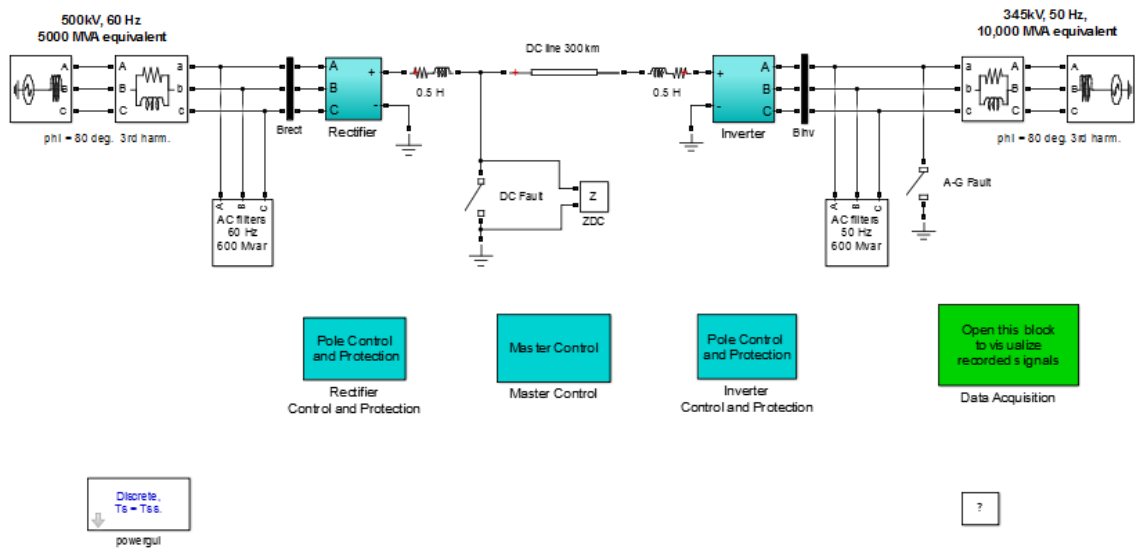

**Figure 5.2 Simulation model of HVDC Transmission 2.**

**VI. Proposed Work**

1. Design a combination of a HVDC transmission system with the proper combination of the converter with PWM and VSC for Inverter and Thyristor for the Source is used.
2. Simulation study is carried out on PSCAD/EMTDC Software package. Run the model in a PSCAD simulation tool.
3. Find the simulating results with analysis of the thermal limit and transient insystem.
4. Analysis of the fault problem and theirsolutions.

Using MATLAB Simulink, the circuit of high voltage direct current electric power transmission is simulated both at normal and faulty conditions. The simulation result shows separately by alternating current circuit, direct current circuit and simultaneous ac-dc circuit.

### 1. Source Output

The power source of the transmission line is 500kv at 50Hz frequency. The output power of the source is three phase power supply which are  $V_a, V_b, V_c$ . We can see on the below figure the output of the source is on the form of Alternating Current.

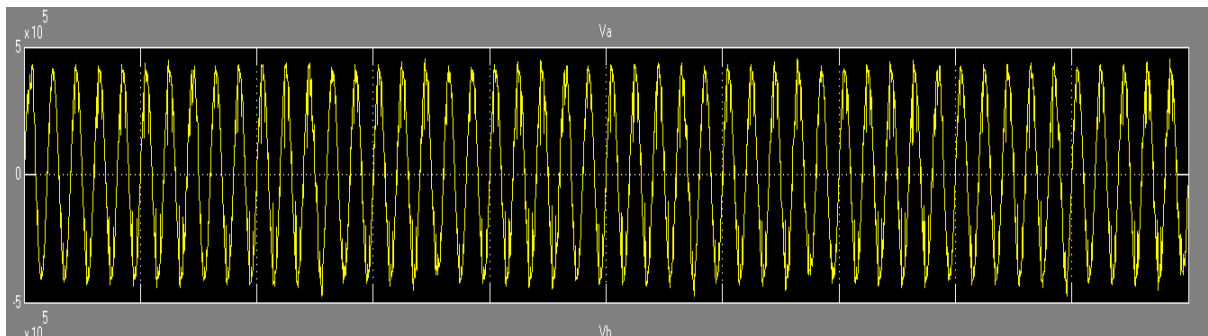

**Figure 6.1 Source Output Voltage and Current at phasea**

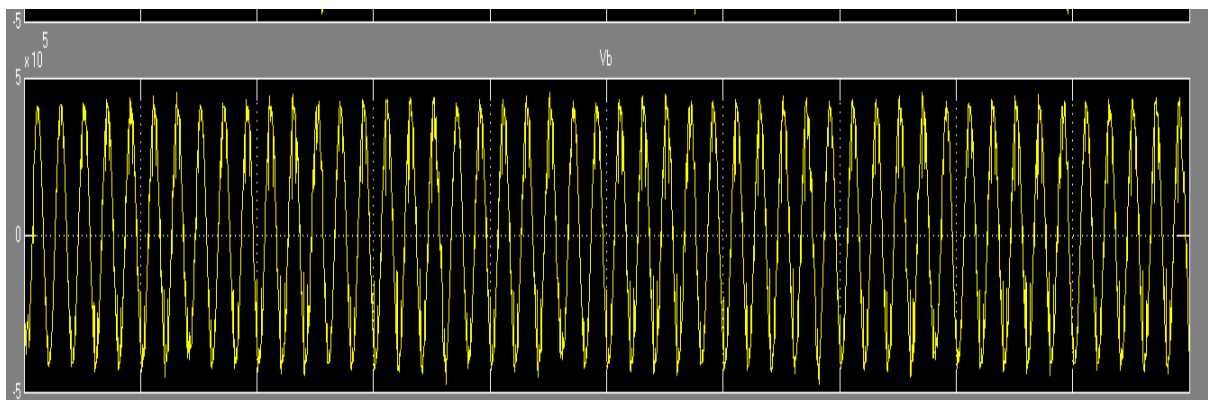

**Figure 6.2 Source Output Voltage and Current at phaseb**

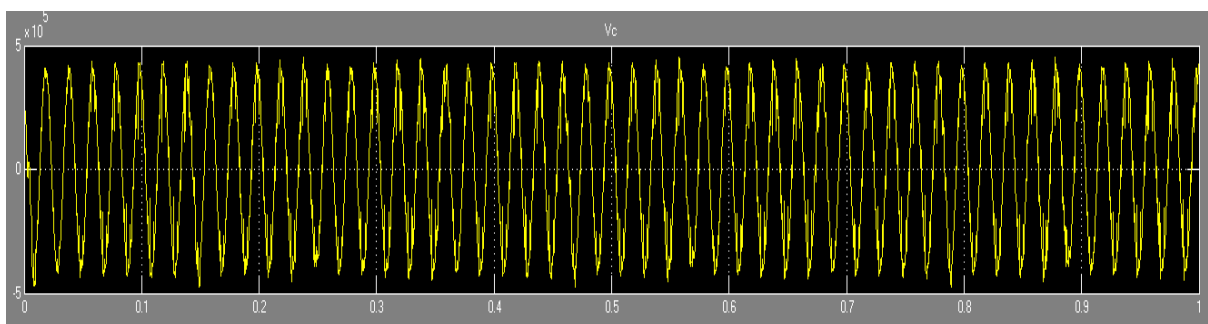

**Figure 6.3 Source Output Voltage and Current at phasec**

## 2. TransmissionOutput

The Output of DC Transmission line at the sending end and receiving end voltage is on the form of a direct current. The amplitude value of  $V_{\text{sending}}$  is  $\times 10^5$  and the amplitude of  $V_{\text{receiving}}$  is  $\times 10^7$ . And the transmission line the DC power is transmitted.

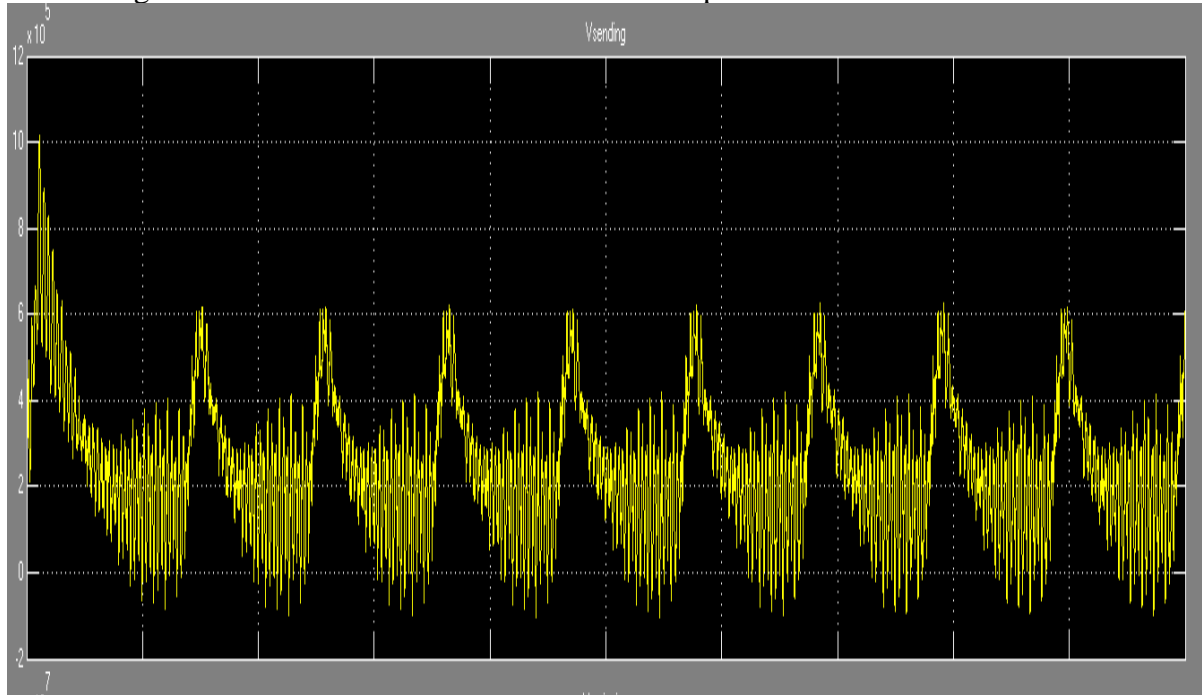

**Figure 6.4 Transmission Output Voltage and Current at sending end**



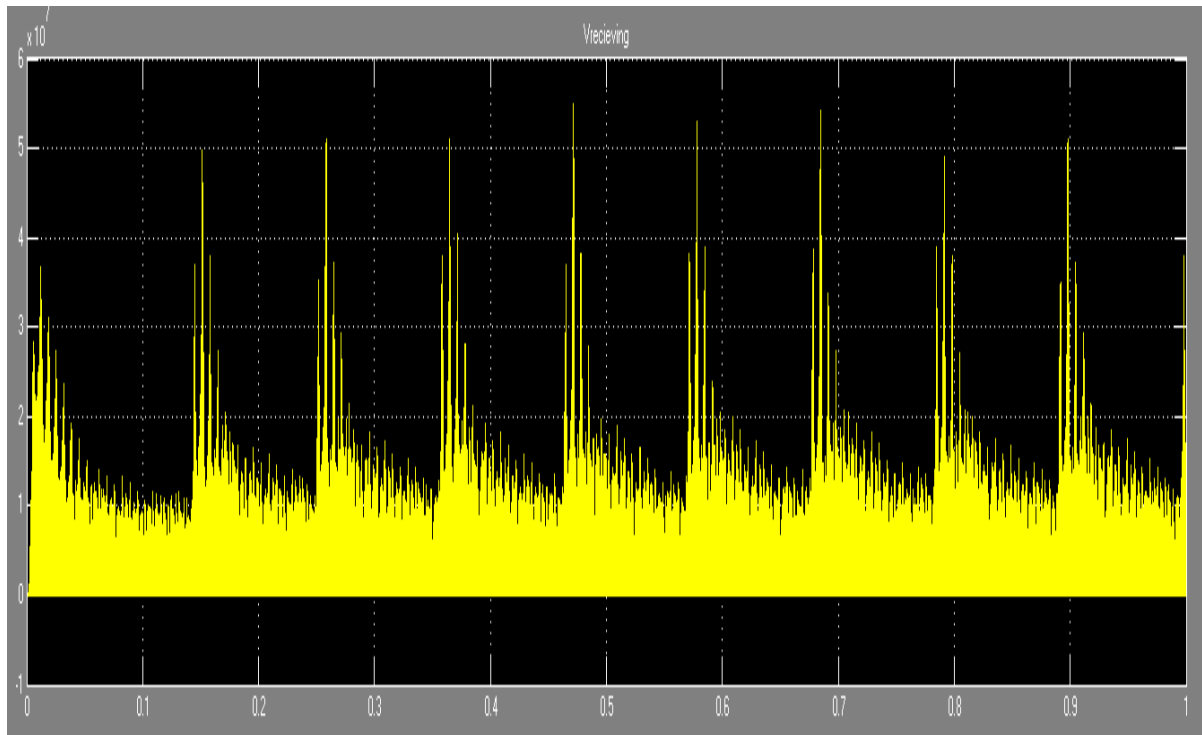

**Figure 6.5 Transmission Output Voltage and Current at receiving end  
InverterOutput**

The output of the inverter is shown in the given figures at respectively phase a, phase b and phase b. The outputs of inverter are in the form of alternating current. This will transmit on the AC transmission line side.

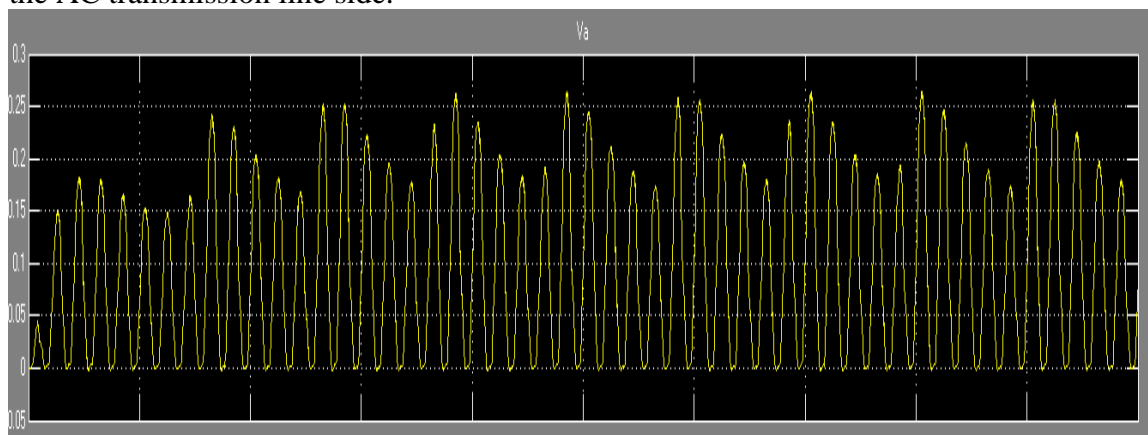

**Figure 5.6 Inverter Output Voltage and Current at phasea**

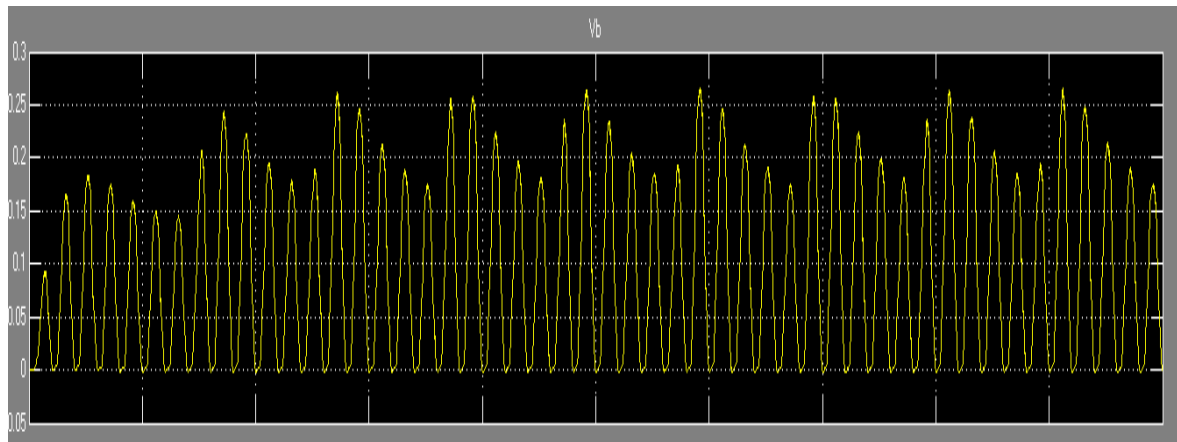

Figure 6.7 Inverter Output Voltage and Current at phase b

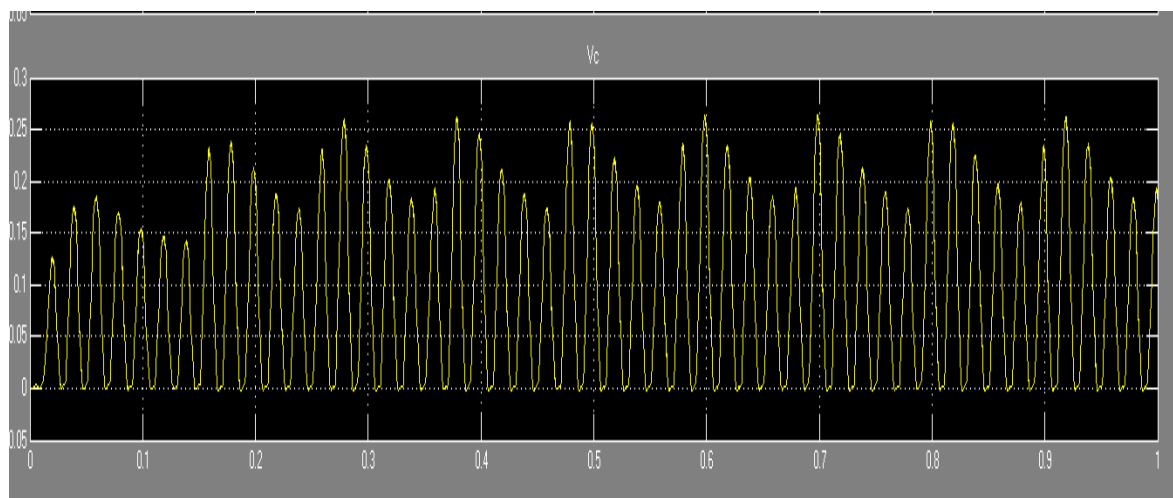

Figure 6.8 Inverter Output Voltage and Current at phase c

## VII. Conclusion

This paper has clearly demonstrated the methodology for modelling steady state operation of HVDC transmission system rectifier using universally available software Matlab/Simulink. A simple scheme of simultaneous EHV ac-dc power transmission through the same transmission line has been presented. Expressions of active and reactive powers associated with ac and dc, conductor voltage level and total power have been obtained for steady state normal operating condition. HVDC is the preferred system for use in a variety of transmission applications, using submarine cables, land cables and overhead lines. The simulation works ensure that simultaneous ac-dc power can be transferred in long distant is possible avoiding thermal limit and transient stability problem. The proposed power system network is very simple and there is no physical alteration in insulator strings, towers and arresters of the original line.

## Tools

1. The study will be carried out using the MATLAB/SIMULINK.
2. MATLAB is a high performance language for a technical computation, computer

programming, visualization, C-language and integrates computation differentiate computation is easy to used in the environments and there problems and the solutions are the expressed in familiar mathematical presentation.

3. MATLAB is the interactive system whose basic data element is an array that does not required dimensioning.

4. MATLAB features a family of application specific solutions are called toolboxes.

#### Reference

[1] P. V. K. Babu, P. B. Prasad, and M. P. Lalitha, "Power Upgrading of Transmission Line by Combining AC-DC Transmission," *Int. J. Of Engineering Research and Applications*, vol. 2, no. 6, pp.1699-1704, Dec.2012.

[2] P. Zuniga-Haro, J. M. Ramirez, "Multi-pulse Switching Functions Modeling of Flexible AC Transmission Systems Devices", *Electric Power Components and Systems*, Volume 37, Issue 1 January 2009, pages 20-42.

[3] Cleric A, Paris L and Danfors P., "HVDC conversion of HVAC line to provide substantial power upgrading," *IEEE Transaction on Power Delivery*, 6(1), 1991, pp.324-333.

[4] Clerici A, Valtorta G and Paris L, "AC and/or DC substantial power upgrading of Existing OHTL Corridors," *AC DC Conference, London, 1991*, pp.220-225.

[5] Brierley R H et al, "Compact Right of Ways with multi-Voltage Towers" *IEEE Transaction on Power Delivery*, Vol.6 No.4, October 1991, pp.1682-1689.

[6] H. Rahman and B H Khan "Stability Improvement of Power System by Simultaneous AC-DC Power Transmission" *Electric Power System Research Journal*, Elsevier, Paper Editorial ID No. EPSRD-06-00732, Press Article No. EPSR-2560—Digital Object Identifier, doi: 10.1016/j.epr.2007.05.020.

[7] N. Flourentzou, V. G. Agelidis, and G. D. Demetriades, "VSC-based HVDC power transmission systems: An overview," *IEEE Trans. Power Electron.*, vol 24, no. 3, pp. 592-602, Mar.2009.

[8] H. Rahman and B H Khan "Possibility of Power Tapping from Composite AC-DC Power Transmission Lines" *IEEE Transaction on Power Delivery*, Vol.23, July 2008, pp.1464-1471.

[9] P.S.Kundur, "Power system stability and control", New York: McGraw Hill Inc., 1994.

[10] PSCAD/EMTDC, "User's Guide", Manitoba HVDC Research

## **“Improvement of Quality Motor Controlling By Using Vector Control PI Base Controller”**

**Kulvinder Singh & Associate Professor Dr.Srikant Prasad\***

### **Abstract**

The induction motors was characterised by complicated, extremely non-linear and time varying dynamics, and thus these speed management can be a difficult drawback within the trade. The arrival of vector management techniques has resolved induction control issues. The vector management Associate in Nursing analysis of an induction motor permits the decoupled analysis where the force and therefore the flux parts is severally controlled (just as in dc motor). This makes the analysis easier than the per part equivalent circuit. In indirect vector management theme a current controlled voltage supply electrical converter is taken into account, through which the stator coil part currents function inputs, thus the stator coil dynamics is neglected. In recent years, the sector familiarized management of induction motor drive is inclusive utilized in high performance drive system. It is to its distinctive characteristics like high potency, smart power issue and very rugged. This paper presents digital simulation of indirect vector management led primarily based speed control of induction motor drive by means that of PI controller mistreatment Matlab/Simulink

### **1.Indirect Vector Control Method**

Industrial drives by manner of potency, dynamic performance, versatile operational characteristics, easy medical specialty and communication with a central laptop. These including the developments in micro-electronics and power devices have diode to a firm trend towards digital management of drives. there a large form of applications similar to machine tools, elevators; mill drives etc., wherever fast management over the force of the motor is crucial. Such applications area unit dominated by DC drives and can't be satisfactorily operated by associate induction motor drive with constant Volt-Hertz (V/f) theme. Over the last twenty years the principle of vector management of AC machines have evolved, by suggests that of that AC motors and induction motors above all, are often controlled to present dynamic performance such as what accomplishable in an exceedingly severally excited DC drive. In recent decades, several studies are done by researchers {to management to regulate|to manage} ac motors just like that of separately-excited dc machines that lead them to vector control theory [1]. Vector management created the ac drives similar to dc drives within the freelance management of flux and force. the prime disadvantage of the indirect vector management theme is that it's machine parameter dependant, since the model of the motor is employed for flux estimation. The machine parameters area unit full of variations within the temperature and therefore the capacity levels of the machine. Any match between the parameters within the motor which instrumented within the vector controller can lead to the deterioration of performance in terms of steady state error and transient vacillations of rotor flux and force. These styles of oscillations don't seem to be desired for a few actual uses. Concerning the importance of sensitivity of vector management drive to the motor parameters, several investigations are

---

\*Mtech (EEE), OP Jindal University Raigarh (C.G)

distributed through this field. In [2] the results of rotor resistance and coefficient variations on output force and rotor flux are mentioned qualitatively. Within the alternative work the impact of the machine parameters distinctions on its outputs, touching on simulation results has been investigated and 2 techniques for rotor resistance estimation are delineated [3]. Krishnan in [4] has derived approximate equations for parameter sensitivity of indirect vector control; and eventually in some references, motor parameter estimation and reimbursement techniques and their impact on machine outputs are delineated [5]-[9]. During this paper actual equations of parameter sensitivity are derived. victimization derived equations, the impact of parameter variations on the outputs of the machine are often determined.

## **2. Theory of Vector Control**

Vector control, also called field-oriented control (FOC), is a variable-frequency drive (VFD) control method in which the stator currents of a three-phase AC electric motor are identified as two orthogonal components that can be visualized with a vector. One component defines the magnetic flux of the motor, the other the torque. The control system of the drive calculates the corresponding current component references from the flux and torque references given by the drive's speed control. Typically, proportional-integral (PI) controllers are used to keep the measured current components at their reference values. The pulse-width modulation of the variable-frequency drive defines the transistor switching according to the stator voltage references that are the output of the PI current controllers. FOC is use control AC synchronous and induction motors. It was originally developed for high-performance motor applications that are required to operate smoothly over the full speed range, generate full torque at zero speed, and have high dynamic performance\_including\_fast acceleration and deceleration. However, it is becoming increasingly attractive for lower performance applications as well due to FOC's motor size, cost and power consumption reduction superiority.<sup>[3][4]</sup> It is expected that with increasing computational power of the microprocessors it will eventually nearly universally displace single-variable scalar volts-per-Hertz (V/f) control

## **3. Speed Controlling**

Variable speed drive systems are essential in many industrial applications. In the past, DC, are require to high speed synchronous circuit because these improved efficiency of induction motor, since their control flux and armature current of induction motor. Dc motors have certain disadvantage they are totally depends for brushes and large current loss. That is, they have required for large periodicity of torque; they cannot be used in explosive or corrosive environments and they have limited commutator these properties are high speed and higher alternate current and rugged Structure of motor. That is providing high maintainability and good economy.

## **4.DirectOrQueControl**

Direct torque control (DTC) and field-oriented control (FOC) are becoming the industrial standards for induction motors torque control [1]. Research work have compared to the FOC and DTC pointing to this last as the drive suitable for applications for quick response dynamic [1]-[3]. The first developments of the concept of DTC occurred in [3]- [4], popularized thanks to the quick response of torque and robustness to the variation of the parameters of the machine. Its structure is based on two hysteresis comparators and an interrupt vector table designed to control torque and flux [1]-[5]. In the traditional DTC scheme the stator flux is estimated by the voltage model of the motor. This estimation

requires the integration of the stator back emf, which is determined subtracting the voltage drop across the stator resistance from the stator voltage. This model depends on accurate detection of the voltages and currents, integration technique and correct knowledge of stator resistance. However, the integrator of voltage model causes saturation and initialization errors due to the signal offset DC caused by the use of analog components such as sensors and amplifier circuits for measurements of voltages and currents. Low pass filters are typically used instead of pure integrator to avoid the drawbacks in the implementation [6]-[8]. However, the filters degrade the dynamic response of the electric drive [8]. On the other hand, the DTC in voltage model is inoperable at speeds close to zero, due to the dependence of the resistance of the stator [6]. In this research shows the performance of DTC scheme in current model made in [8]. Its scheme requires the knowledge of speed, rotor time constant and inductive parameters of the motor resulting in a wide range of operating speeds. Other feature of DTC is the high starting currents due to the quick response to torque provided by the strategy. These currents bring as a consequence activation of the inverter protections of the system causes stopping the system. Therefore it requires a current limiter, feedback on current vector affecting the optimum switching table [9]. In this paper we analyze the dynamic response of the electric drive of DTC in the current model from different speed ranges, together with the current starting limiter to operationalize the system. Experimental tests based on these techniques are presented.

#### **5. Advantages of Proposed Algorithm**

- The sensors are eliminated.
- The dynamic performance of the indirect induction control is better than the direct induction control
- The cost factor is decreased.
- There is no drift problem as in direct induction control.

#### **6. Proposed Methode and Its Description**

For electrical drives good dynamic performance is mandatory so as to respond to the changes in command speed and torques. These requirements of AC drives can be fulfilled by the vector control system. It consists of a slip frequency calculation, Inverter, Voltage and current sensing Elements, integrator of error speed signal Speed sensor element and the corresponding Phase diagram is shown in Fig.1 the advent of the vector control method, an induction motor has been controlled like a separately excited DC motor for high performance applications. This method enables the control of field and torque of induction motor independently (decoupling) by manipulating corresponding field-oriented quantities. The traditional indirect vector control system uses conventional PI controller in the outer speed loop because of the simplicity and stability. However, unexpected change in load conditions or environmental factors would produce overshoot, oscillation of motor speed, oscillation of the torque, long settling time and thus causes deterioration of drive performance. To overcome this, an intelligent controller based on Fuzzy Logic can be used in the place of PI regulator. The fuzzy logic has certain advantages compared to classical controllers such as simplicity of control, low cost, and the possibility to design without knowing the exact mathematical model of plant The Vector control techniques have made possible the application of induction motors for high-performance applications, where traditionally only DC drives were applied. The vector control scheme enables the control of the induction motor in the same way as separately excitation DC motors. As in the DC



motor, torque control of induction motor is achieved by controlling the torque current component and flux current component independently. In the indirect vector control method, the rotor field angle and thus the unit vectors are indirectly obtained by summation of the rotor speed and slip frequency

For high performance drive the indirect method of vector control is preferred. The indirect vector control method is essentially same as the direct vector control except that the rotor angle is generated in an indirect manner using the measured speed  $r$  and the slip speed  $s\omega$ . To implement the indirect vector control strategy, it necessary to take the following dynamic equations into consideration. With respect to phasor diagram of Indirect Vector Control method of induction motor.

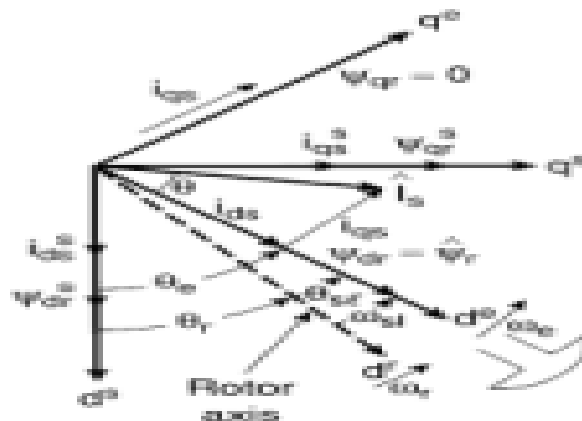
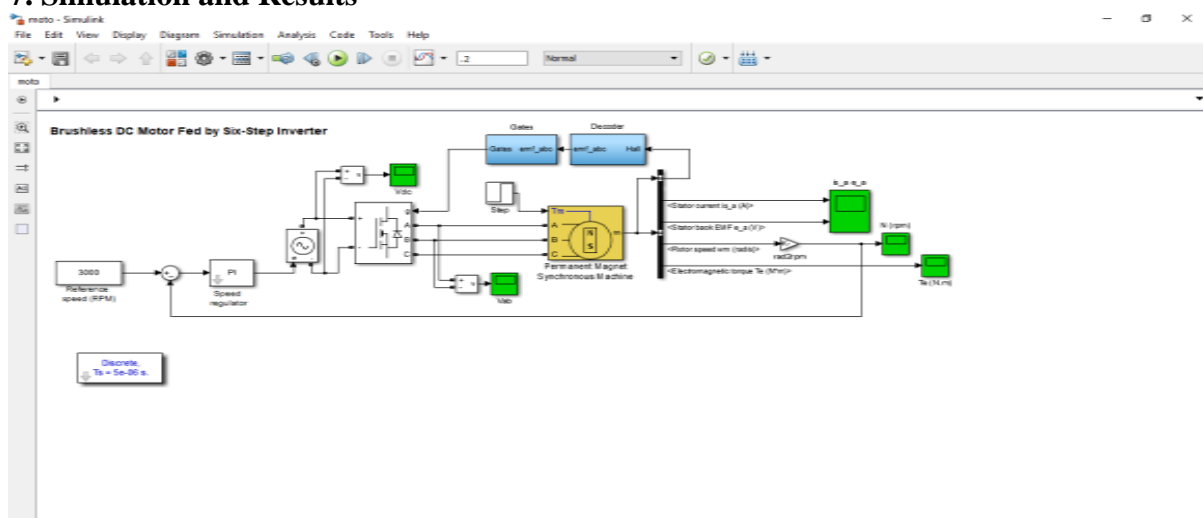

Diagram indirect vector control method of Induction motor

## 7. Simulation and Results



Simulink modeling in Vector controlling induction Motor

### 7.1 Simulink Modelling In DC Control Technique

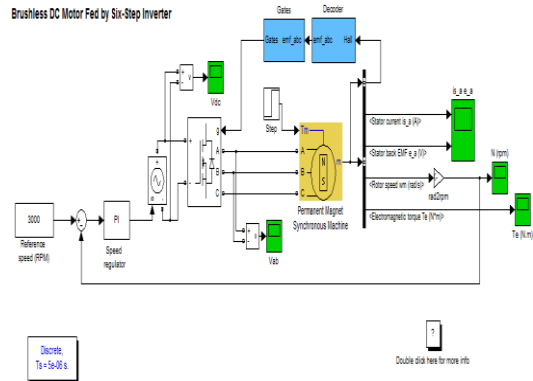

Figure (7.1) Simulink Modeling in DC Vector  
7.2 Output Waveform in DC Controlling DC Motor

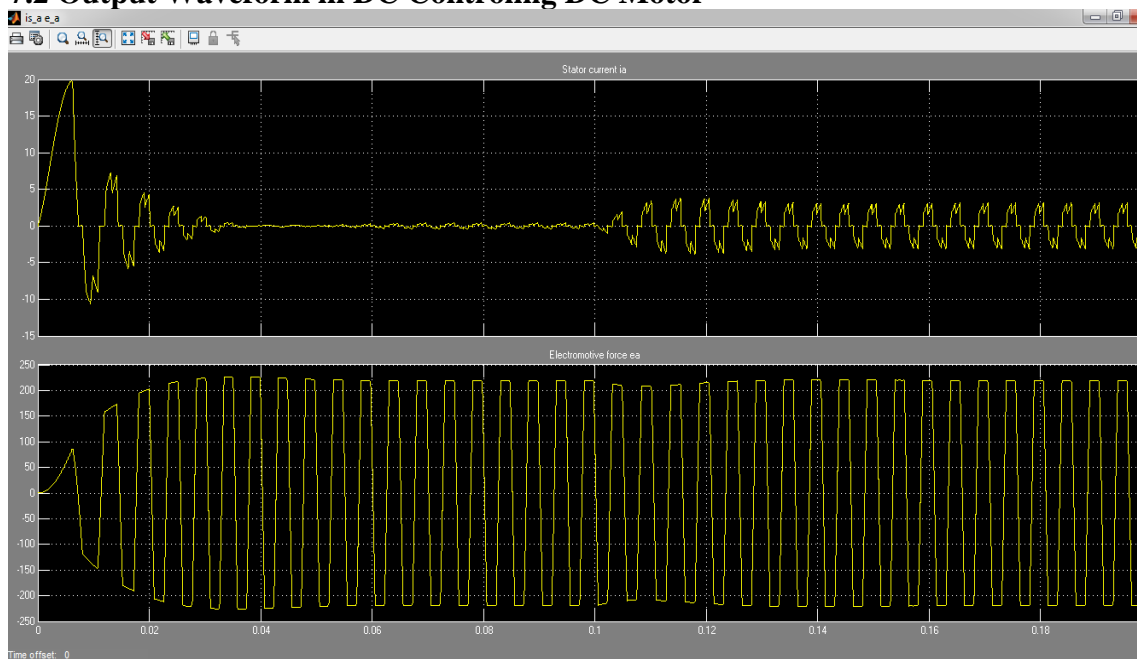
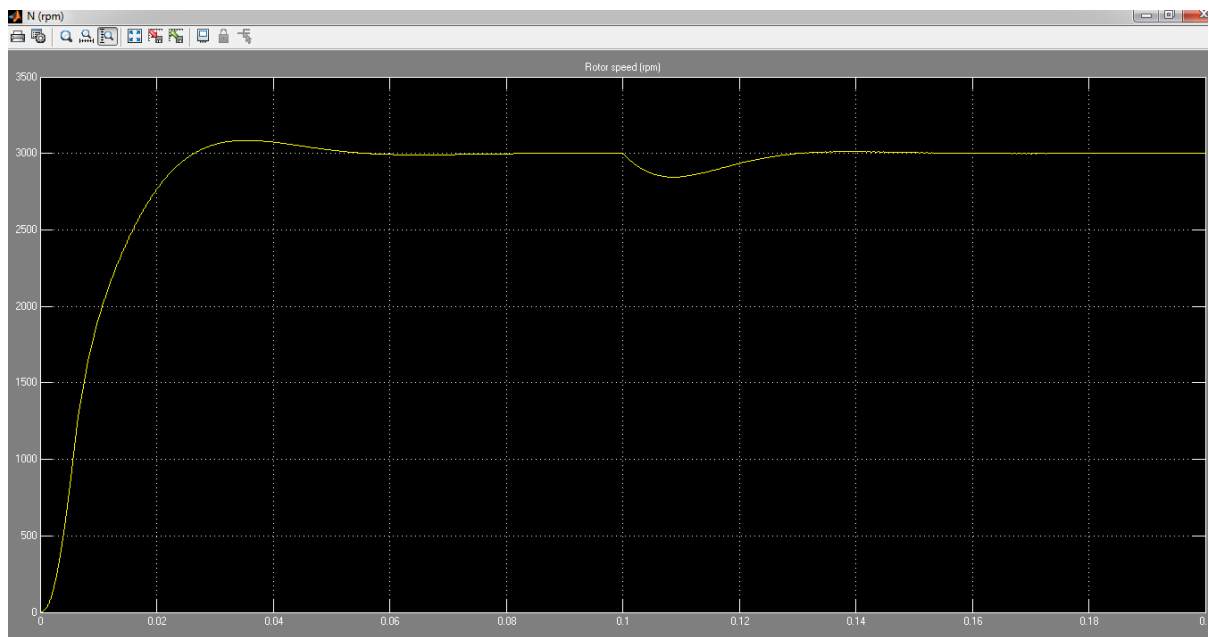
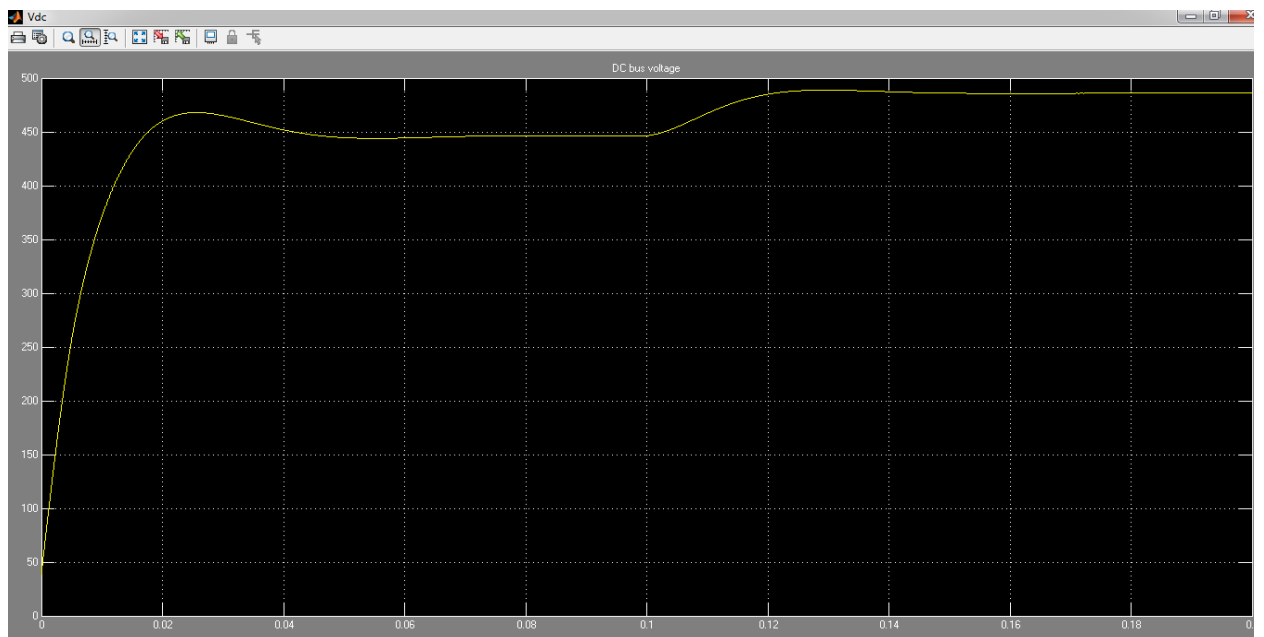

Figure (7.2)  $V_{ab}$  PWM output,  $I_{ab}$  Current, Rotor speed, Electromagnetic Torque induced in Induction MOTOR



**Figure (7.3)DC regulated output**



**Figure (7.4)PI Controller**

### 7.3 Power GUI in Project

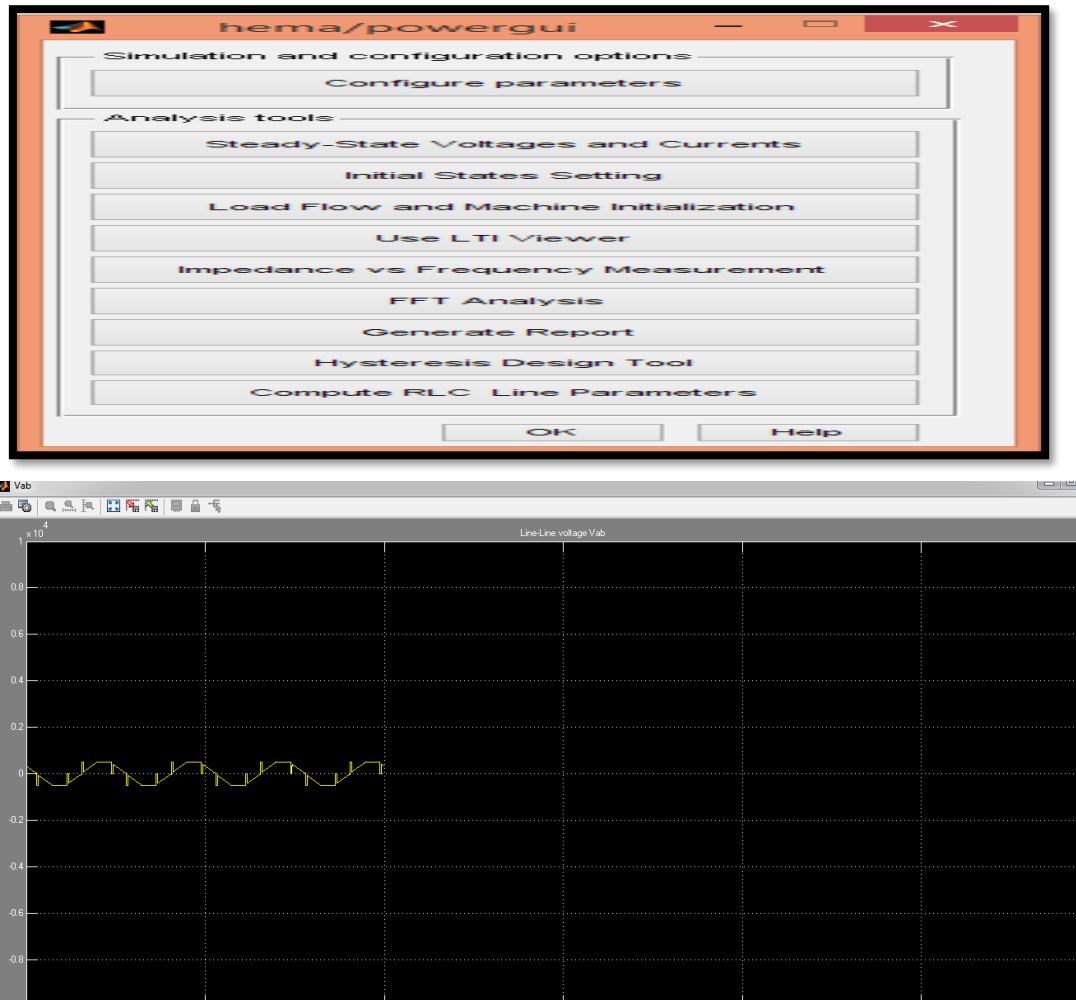

Figure (7.5) SIX steps output

### 7.4 Single-Phase Asynchronous Machine - DC Control

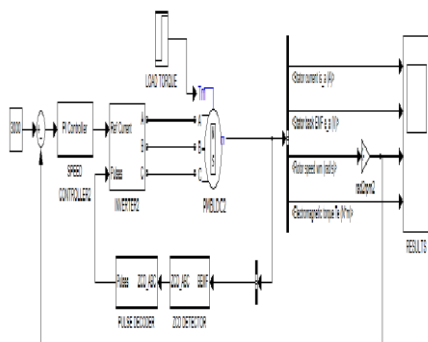

Figure (7.6) Asynchronous motor output

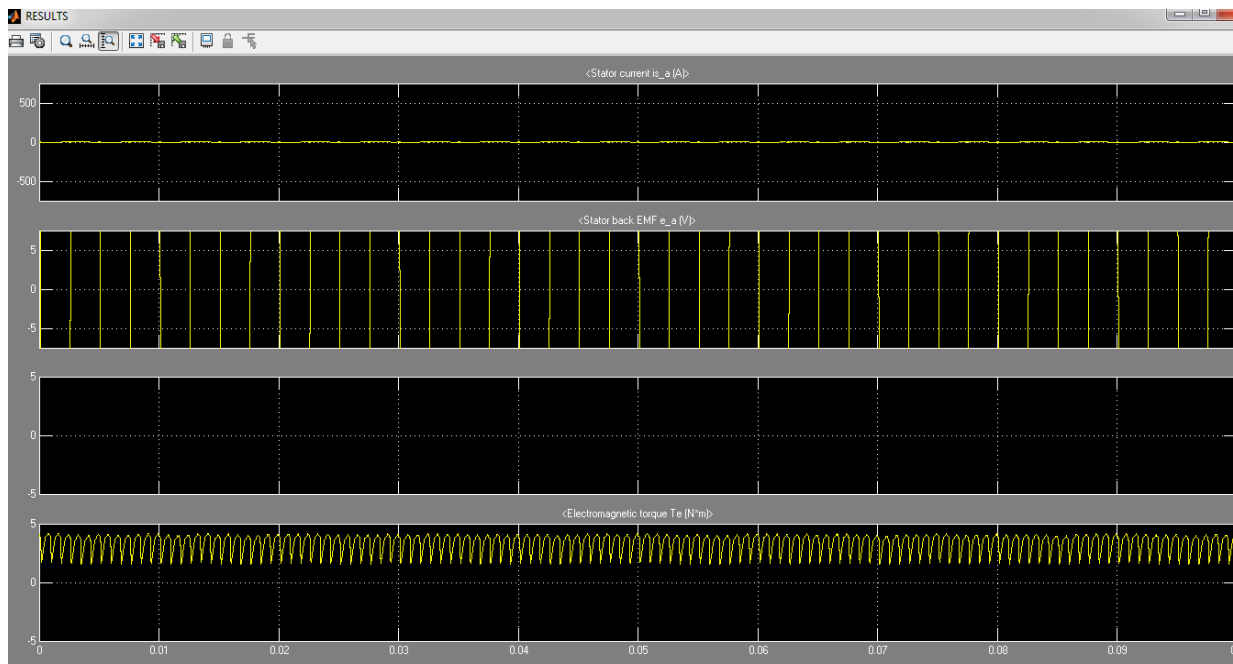

Figure (7.7) Single-phase DC machine

## 8. Conclusions and Future Study

The performance of indirect vector control logic based intelligent controller for the speed control of Indirect Vector Controller, Voltage Source Inverter Fed Induction Motor Drive has been verified and compared with that of conventional PI controller performance. The simulation results were obtained and it will confirm that, it is very good dynamic performance and robustness of the indirect vector control Logic Controller during the transient period and during the sudden loads. It is concluded that the proposed intelligent indirect vector control logic controller has shown superior performance than that of the parameter fixed PI controller of conventional method.

### Reference

- [1] Blaschke F., "The Principle of Field Orientation as Applied to the New Transvektor Closed-Loop Control System for Rotating -Field Machines". Siemens Rev., 39, 5, May 1972, pp. 2 17-220.
- [2] Blaschke F., "Das Verfahren der Feldorientierung zur Regelung der Drehfeldmaschine" Techn. Univ. Braunschweig, Dissertation, 1973.
- [3] Hasse K., "Zur Dynamik drehzahl geregelter Antrieb mit Stromrichter gespeisten Asynchron Kurzschlusslaufermaschinen". Techn. Hochsch. Darmstadt, Dissertation, 1969.
- [4] Pedro Ponce & Jaime Rodriguez Rivas., "Simulation del Control por Campo Orientado de Motores de Induccion". IEEE RVP 97.
- [5] Bimal K. Bose "Power Electronics and Variable Frequency Drives", IEEE Press
- [6] Pedro Ponce & Jaime Rodriguez Rivas., "Estimacion de la Constante de Tiempo del Rotor del Motor de Induccion Mediante un Modelo de Flujo Adaptable del Sistema". IEEE RVP 98, pp. 373-379, Tomo I.

[7] Murphy J.M.D. &Turnbull F.G. "Power Electronic Control of A.C. Motors", Pergamon also estimates the rotor flux satisfactorily. Press, 1988.

[8]Ben-Brahim L., Gastli A., Al-Hamadi M., *Auto- Tuning for Sensorless AC Motor Drive Systems*. IEEEInt.Symp.on Ind. Electronics, Bled, Slovenia, 367-372, 1999.

[9] Onea A, Horga V., *Educational Software Environment for Motion Control*. Proc. of the IASTED 5th Int.Conf.on Comp. and Adv. Techn.in Education, 334-339, 2002.

[10] D. Casadei, F. Profumo and G. Serra, "FOC and DTC: two viable scheme for induction motors torque control", IEEE Transactions on Power Electronics, vol. 17, no. 5, pp. 779-787, September 2002.

[11] A. Chikhi, M. Djarallah and K. Chikhi, "A comparative study of fieldoriented control and direct-torque control of induction motors using an adaptive flux observer", Serbian Journal Of Electrical Engineering, vol. 7, no. 1, pp. 41-55, May 2010.

[12] I. Takahashi and T. Noguchi, "A new quick-response and high efficiency control strategy of an induction motor", IEEE Transactions on Industry Applications, vol. 1A-22, no. 5, pp. 820-827, September/October 1986.

[13] M. Depenbrock, "Direct self-control (DSC) of inverter-fed induction machine", IEEE Transactions on Power Electronics, vol. 3, no. 4, pp. 420-429, October 1988.[14] P. Vas, *Sensorless Vector and Direct Torque Control*, Oxford Science Publications, 1998.



---

## **Comparative Analysis of Regular Building V/S Irregular Building under SEISMIC Load**

**Vikas Ahlawat\***

**Mr. Durgesh Nandan\*\***

### **Abstract**

*The necessary earthquake resistant capacity in a multi-storied building can be achieved by providing adequate stiffness, strength and ductility in the building and it has been seen amid past seismic tremors that structures which are regular in design perform much superior to anything those which have irregular design. In this way, it is constantly attractive to embrace a regular configuration of an elevated structure while designing. Shear wall is an element which acts as a vertical cantilever used generally in multi storied building to resist lateral forces like wind, storm, and earthquake and it provides an optimal means of achieving the basic criteria of design. This paper presents the results of study carried out on three distinct instances of building (i) Regular building having rectangular configuration and (ii) Irregular building having L shape configuration and (iii) Irregular building having irregular grid formation of column and beams, are considered in order to understand the behaviour of an irregular building with simple moment resisting frame having beam, columns and two way slabs and to study the effect of providing shear wall on the performance of these buildings under seismic loading. All the cases of building are thought to be situated in zone IV. Linear dynamic analysis through Response Spectrum method is carried out utilizing the standard STAAD.PRO programming bundle.*

**Key Words:** Shear wall, multi-storied building, dual structural system, Staad-pro, irregular building, etc.

### **1. Introduction**

An earthquake might be characterized as the release of elastic energy by a sudden slip on a fault and coming about ground shaking and transmitted caused by slip. It is a standout amongst the most devastating natural hazards normal perils that reason extraordinary death toll and livelihood. The greater part of the misfortunes is because of building collapse or damages. An Earthquake can cause harm not just by virtue of vibrations which comes about because of them yet in addition because of other chain impacts like landslides, surges, fires, and so on. An extensive structural analysis of a multi-storied building is dependably a mind boggling undertaking, particularly for a high rise building having plan irregularities. For an irregular building having plan irregularities, it is important to use the dynamic method of analysis to get the reaction parameters. For sure, the reaction of any building under the action of seismic forces is exceptionally complex and Response spectrum method of analysis ends up being a superior choice to acquire the reaction of the structure under the activity of seismic forces. Besides, the important earthquake resistant ability in a multi-storied building can be accomplished by giving sufficient stiffness, strength and ductility in the building and shear wall gives an ideal mean for accomplishing the fundamental criteria of design [T. Paulay and M.J.N Priestley, 1992].

---

\* M.E student, Civil Engineering Department, Gateway Institute of Engineering and Technology, Sonipat, India

\*\* Professor, Civil Engineering Department, Gateway Institute of Engineering and Technology, Sonipat, India

### **1.1 Shear wall**

Shear walls are when all is said in done continuous component beginning from the foundation and go up to the most elevated point of the building (generally made of steel or reinforced concrete). In any case, it might likewise be curtailed at middle height. Shear wall can oppose the blend of shear, moment and axial load incited by lateral load and gravity load exchanged to it through other structural members.

### **Earthquake load Resisting Mechanism of shear wall**

Utilization of shear walls gives an effective solution to stiffen a structural system of a building as it increases the rigidity against horizontal load acting up on the building. Shear wall essentially increases the stiffness and strength of the building toward its orientation. These outcomes in checked decrease in lateral sway of the building. By and large the Shear wall transfers the load to the next component beneath it in the load path. It helps in reducing the side sway of the above individuals like roof or floor. It also keeps the floor and roof framing individuals from moving off their supports when they are stiffened enough and furthermore diminishes the non structural damages [2].

### **1.2 Classification of shear wall**

Shear wall may be classified into different types on the basis of various parameters:-

On the basis of Aspect ratio i.e. Height to width ratio (or height to length ratio) [N Sivakumar et al., 2014]

1. Short or Tall wall
2. Slender wall, Squat wall or combination of the two

On the basis of Material [T. Paulay and M.J.N Priestley, 1992]

1. Reinforced concrete shear wall
2. Steel plate Shear wall
3. Plywood shear wall
4. Mid-ply shear wall
5. RC hollow concrete block masonry shear wall

On the basis of Shape

1. Deep straight walls
2. U shaped walls
3. Box shaped walls

On the basis of shape and their position

1. Simple rectangular type shear wall
2. Coupled Shear wall
3. Rigid frame Shear wall
4. Framed walls with in filled frames
5. Columns supported shear wall
6. Core type shear wall

### **2. Objective of Studies**

Main objective of the present work is to evaluate the performance of an RC building having plan irregularities using response spectrum method of analysis to study the effect of providing shear wall on the performance of the building under seismic loading in seismic zone IV.

[1] Structural analysis of six different cases of a G+19 building with and without shear wall in seismic zone IV of India, having different configurations viz. (i) Regular building

having rectangular configuration, (ii) Irregular building having L shape configuration and (iii) Irregular building having irregular grid formation of beams and columns.

[2] Working out the Inter-storey drift, Drift Reduction factor and Base shear.

[3] Comparing the response parameters to study the effect of irregular configuration on the performance of building under the action of earthquake load and also the effect of providing shear wall in seismic zone IV.

### **3. Methodology**

A building is said to be irregular if it possesses plan irregularities (if structural elements cannot be arranged in proper grid) or vertical irregularities, which is due to the presence of soft story in high rise buildings [as per clause 7.1, IS 1893 Part (I)]. This work aims to study the seismic performance of the dual structural system of multi-storied buildings having plan irregularities, which essentially comprises of analysis and comparison of response parameters of the building having regular configuration of rectangular shape without shear wall, with shear wall, irregular building having L shape configuration without shear wall and with shear wall subjected to earthquake loading.

In this attempt, following major works will be accomplished:-

[1] Considering six different cases of building having regular and irregular configuration with shear wall and without shear wall.

[2] Deciding the design parameters such as size of columns, beams, shear wall, etc. as per the guidelines of IS 1893:2016 (Part 1).

[3] Modelling of various structures.

[4] Carrying out detailed analysis of bare frame models and dual structural system with shear wall

[5] Plotting curves between storey height and storey drift, base shear, etc.

### **Description of the structure**

A building having regular configuration of rectangular shape, a building having irregular configuration of L shape and an irregular building having irregular grid formation of columns and beams are considered to prepare various three dimensional bare frame model and shear wall-frame model of the building. The building is having a typical floor height of 3 meters. The structure will be analyzed for seismic loads using STAAD.PRO software package.

The following assumptions are considered for the dynamic analysis.

[1] All supports are assumed to be fixed.

[2] Un-cracked sections for beams and columns are used in the analysis.

[3] Shear deformation effects are neglected.

[4] The floor diaphragms are rigid enough to distribute uniformly the lateral loads on the vertical elements.

[5] The out of the plane deformations are absorbed by rigid horizontal diaphragms.

### **Modelling Approach**

The modeling approach includes the preparation of a centerline plan of the irregular building to obtain the coordinates of various joints followed by specifying the nodal coordinates data for the development of model using STAAD.PRO.

### **Analysis Procedure**

IS 1893(Part I): 2016 recommends the method of dynamic analysis for the following:-

[a] Regular buildings- those higher than 40 meters in height in seismic zone IV and V, and those higher than 90 meters in Zone II and III.

[b] Irregular buildings- all framed buildings higher than 12 meters in zone IV and V, and those higher than 40 meters in zone II and III.

As per the code recommendation, dynamic method of analysis has been adopted for the analysis of building. The main purpose of the dynamic analysis is to obtain the design seismic forces, followed by its distribution to different levels along the height of the building and to various lateral load resisting elements. There are various methods for the dynamic analysis of a building, out of them Response spectrum method has been chosen for the analysis.

#### **Response Spectra Method**

The main purpose of the response spectrum analysis is to obtain the design seismic forces, with its distribution to different storey levels along the height of the building and to the various lateral load resisting elements. This method is based on the assumption that the dynamic response of the structure may be found by considering the independent response of each natural mode of vibration and then combining in the same way to compute the total response.

#### **4. Analysis of Building by Response Spectrum Method Using STAAD PRO**

Main objective of the present work is to evaluate the performance of an RC building having plan irregularities using response spectrum method of analysis to study the effect of providing shear wall on the performance of the building under seismic loading in seismic zone IV. The specific aims and objectives of the project is the structural analysis of four different cases of a G+19 building with and without shear wall in seismic zone IV of India, having different configurations viz.

1. Regular building having rectangular configuration without shear wall.
2. Regular building having rectangular configuration with shear wall.
3. Irregular building having L shape configuration without shear wall.
4. Irregular building having L shape configuration with shear wall.
5. Irregular building having irregularity in grid formation of column and beams without shear wall, termed here as B3 (W).
6. Irregular building having irregularity in grid formation of column and beams with shear wall, termed here as B3 (S).

#### **Loadings and Factors Considered**

[1] Dead load on all the floors- 4 KN/m<sup>2</sup>

[2] Live load on typical floor- 4 KN/m<sup>2</sup>

[3] Zone factor = 0.36 (for zone iv)

[4] Importance factor = 1

[5] Response reduction factor = 5

[6] Damping = 5 %

[7] Medium soil site

#### **Load combinations**

Load combinations considered for the dynamic analysis are as follows:

1. 1.5(DL+LL)
2. 1.2(DL+LL+EL)
3. 1.2(DL+LL-EL)
4. 1.5(DL+EL)
5. 1.5(DL-EL)
6. 0.9DL+1.5 EL

## 7. 0.9DL-1.5 EL

### Details of the Cases

#### Details of case I

B1 is rectangular shape building having regular configuration, analyzed here as a separate building of G+19 stories, termed as B1-W.

The area of the building = 40 m X 25 m

Typical story height = 3m

Bay along X axis= 5m

Bay along Y axis = 5m

Size of beam throughout the height of the building = 300mmx500mm

Size of Column = 300mmx500mm

Thickness of slab = 120mm

Shear wall is not provided

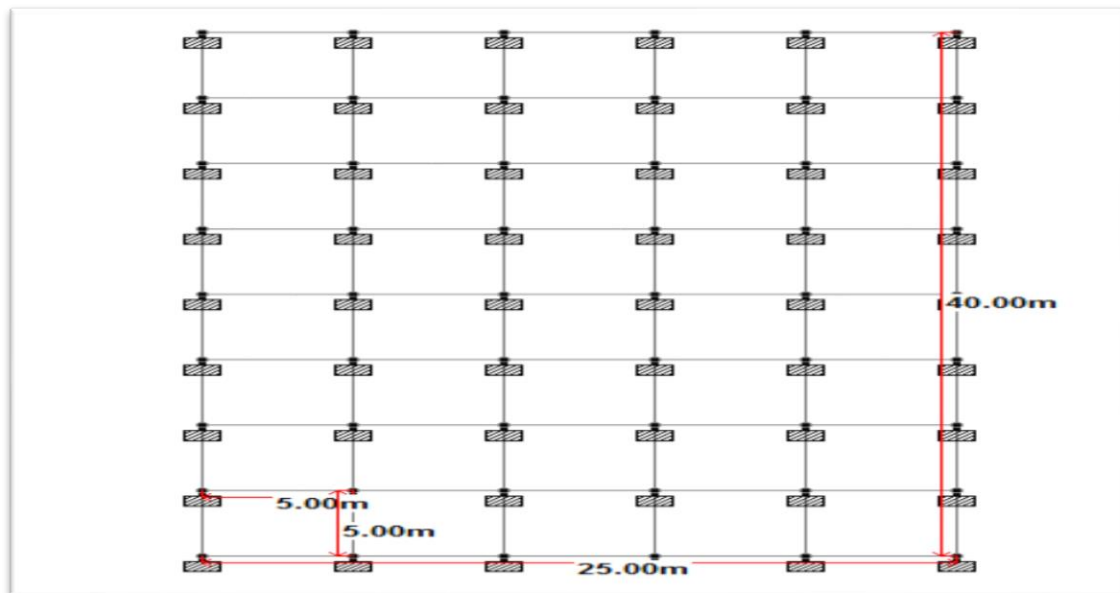

Figure 4.6.1.1 – Plan of Case I

#### Details of Case II

B1 is rectangular shape building having regular configuration, analysed here as a separate building of G+19 stories, termed as B1-S.

The area of the building = 40 m X 25 m

Typical story height = 3m

Size of beam throughout the height of the building = 300mmx500mm

Size of Column = 300mmx500mm

Thickness of slab = 120mm

Thickness of Shear wall = 300mm

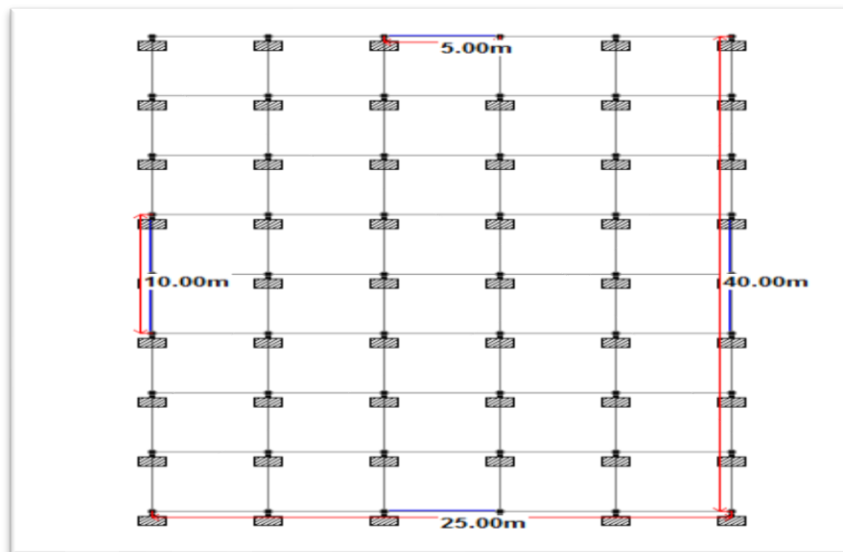

Figure 4.5.2.1 – Plan of Case II

**Details of Case III**

B2 is L shape building having irregular configuration, analysed here as a separate building of G+19 stories, termed as B2-W.

The area of the building = 40 m X 25 m

Typical story height = 3m

Bay along X axis= 5m

Bay along Y axis = 5m

Size of beam throughout the height of the building = 300mmx500mm

Size of Column = 300mmx500mm

Thickness of slab = 120mm

Shear wall is not provided

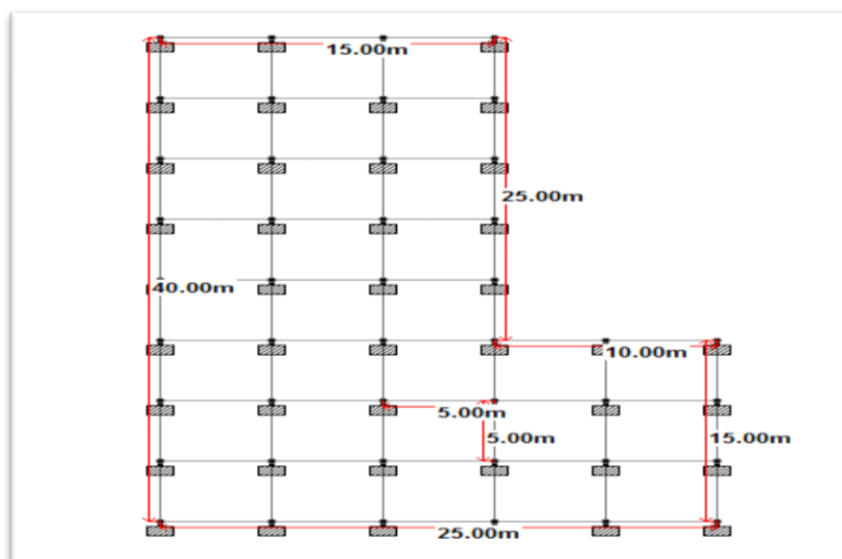

Figure 4.5.3.1 – Plan and 3D view of Case III



### Details of Case IV

B2 is L shape building having irregular configuration, analysed here as a separate building of G+19 stories, termed as B2-S.

The area of the building = 40 m X 25 m

Typical story height = 3m

Size of beam throughout the height of the building = 300mmx500mm

Size of Column = 300mmx500mm

Thickness of slab = 120mm

Thickness of Shear wall = 300mm

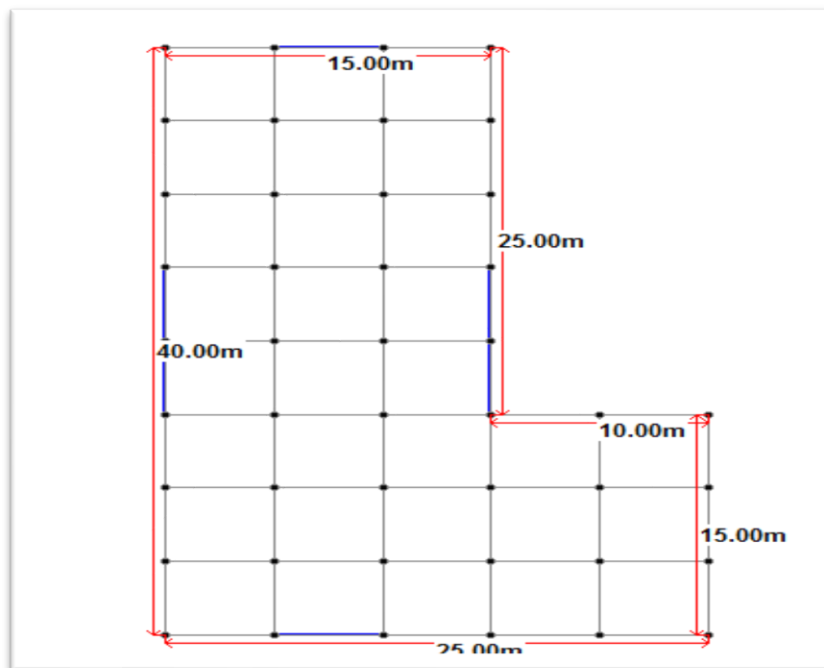

Figure 4.5.4.1 – Plan and 3D view of Case IV

### Details of Case V

B3 is Rectangular shape building having irregular configuration in grid formation of beams and columns, analysed here as a separate building of G+19 stories, termed as B3-W.

The area of the building = 43.37 m X 22.9 m

Typical story height = 3m

Size of beam throughout the height of the building = 230mmx550mm

Thickness of slab = 120mm

Shear wall is not provided.

#### Different sizes of column provided

Nomenclature	Column Size (in mm)
Column C1	300x1350
Column C2	300x1100
Column C3	350x1250
Column C3	300x300

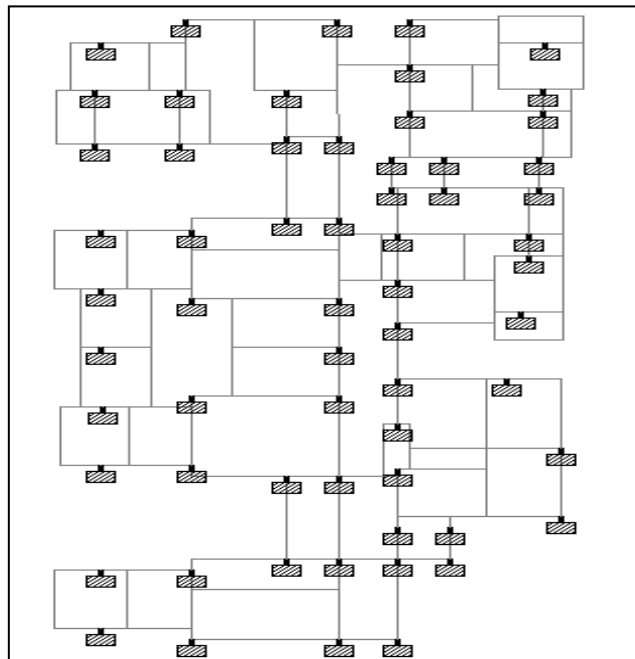

**Figure 4.5.4.1 – Plan and 3D view of Case IV**

**Details of Case IV**

B3 is Rectangular shape building having irregular configuration in grid formation of beams and columns, analysed here as a separate building of G+19 stories, termed as B3-S.

The area of the building = 43.37 m X 22.9 m

Typical story height = 3m

Size of beam throughout the height of the building = 230mmx550mm

Thickness of slab = 120mm

Thickness of Shear wall = 300mm

**Different sizes of column provided**

<b>Nomenclature</b>	<b>Column Size (in mm)</b>
Column C1	300x1350
Column C2	300x1100
Column C3	350x1250
Column C3	300x300

**5. Results and Graphs**

**Effect on storey drift along the building height**

Graphical representation showing variation of storey drift along the building height and the comparisons made between different cases of the buildings B1 and B2 i.e. without shear wall, with shear wall is presented from figure 5.2.1 to 5.2.4. Permissible storey drift in every case is 0.004 times the story height i.e.  $0.004 \times 3000\text{mm} = 12\text{mm}$ .

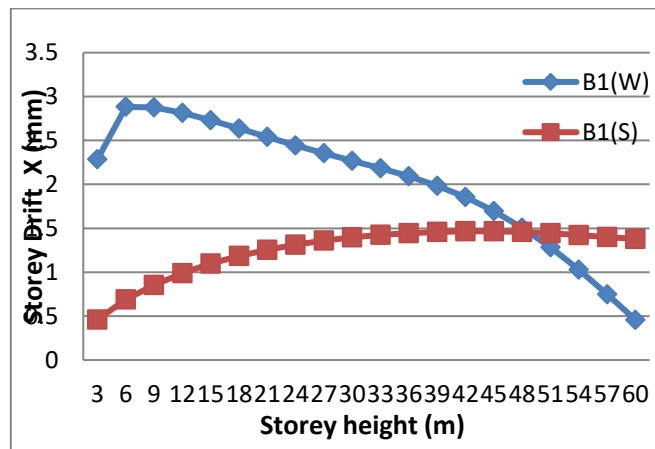

Figure 5.2.1 Comparison of Inter-story Drift along X axis v/s Storey Height for Regular building B1 of (G+19) stories

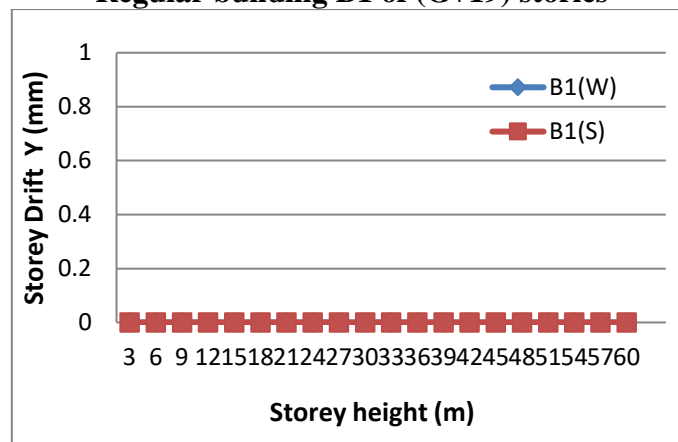

Figure 5.2.3 Comparison of Inter-story Drift along Y axis v/s Storey Height for Regular building B1 of (G+19) stories

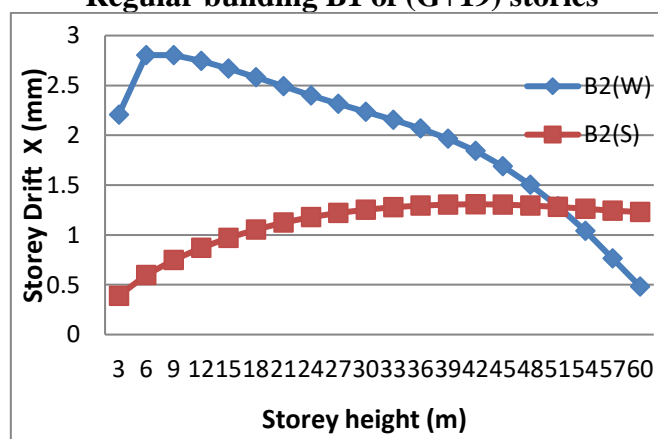

Figure 5.2.3 Comparison of Inter-story Drift along X axis v/s Storey Height for Irregular building B2 of (G+19) stories

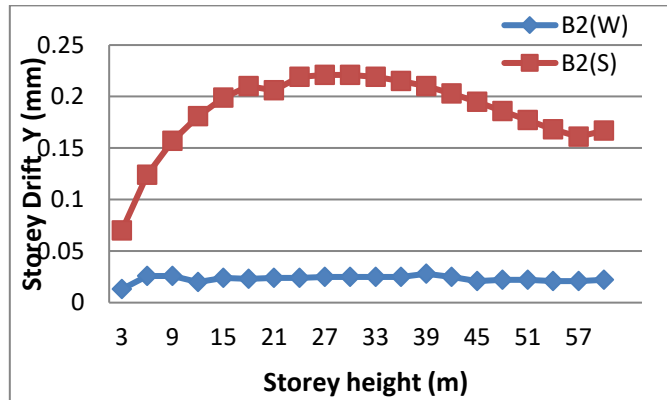

Figure 5.2.3 Comparison of Inter-story Drift along Y axis v/s Storey Height for Irregular building B2 of (G+19) stories

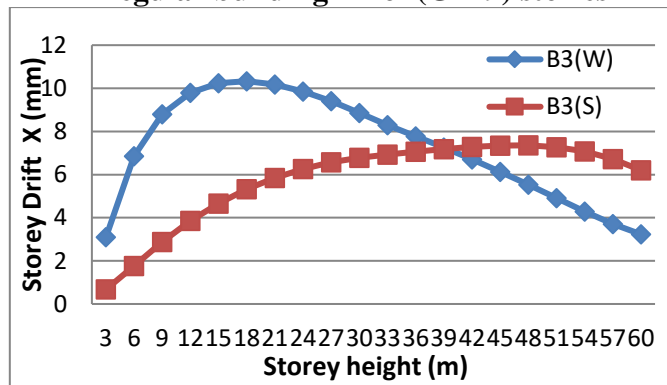

Figure 5.2.3 Comparison of Inter-story Drift along X axis v/s Storey Height for irregular building B3 of (G+19) stories

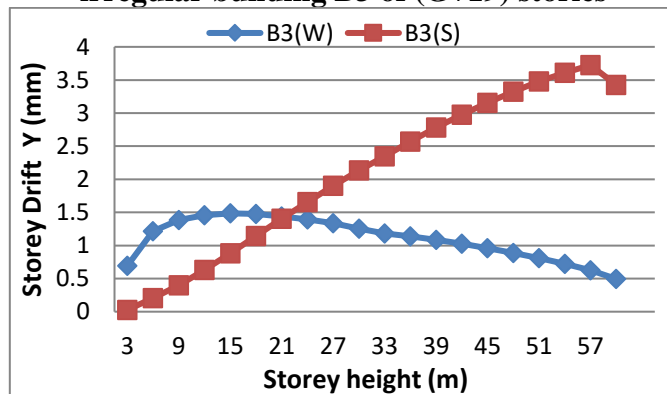

Figure 5.2.3 Comparison of Inter-story Drift along Y axis v/s Storey Height for Regular building B3 of (G+19) stories

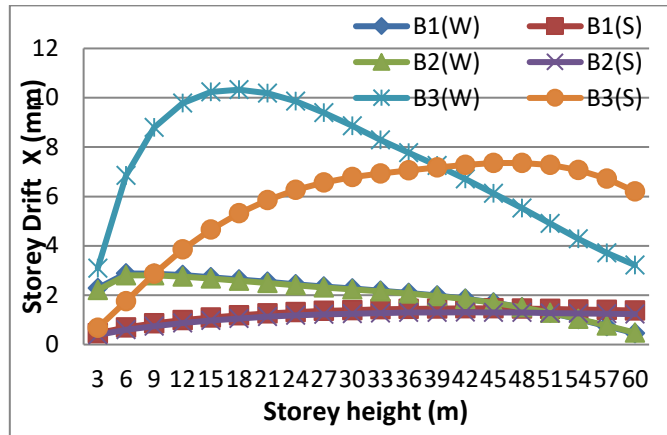

Figure 5.2.1 Comparison of Inter-story Drift along X axis v/s Storey Height for building B1, B2, B3 of (G+19) stories

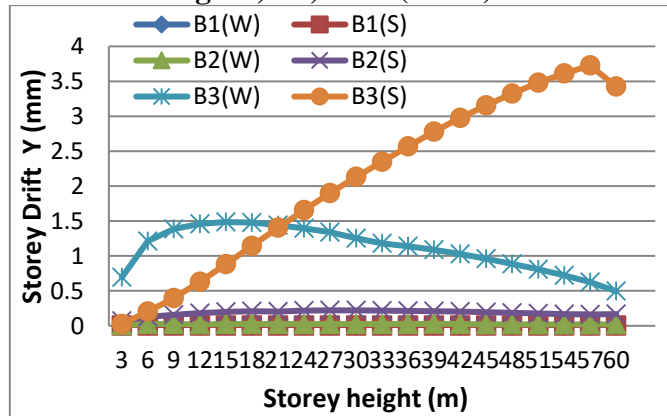

Figure 5.2.1 Comparison of Inter-story Drift along Y axis v/s Storey Height for building B1, B2, and B3 of (G+ 19) stories

**Effect on Design Base Shear**

Graphical representation showing variation of Base shear and the comparisons made between different cases of the buildings B1, B2 and B2 i.e. without shear wall, with shear wall is presented below

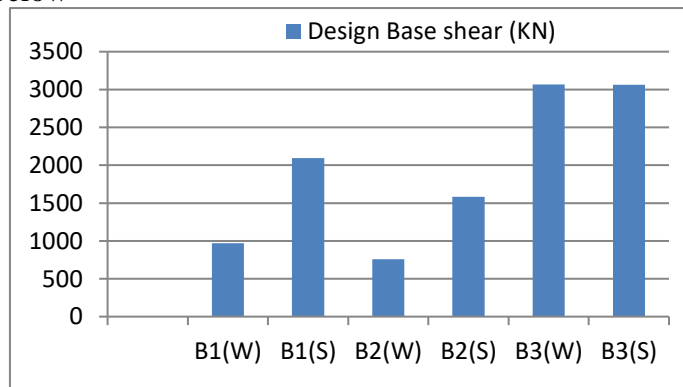

Figure 5.3.1 Comparison of Base shear for different cases of the buildings B1, B2 and B3 of (G+19) stories

### Effect on Drift Reduction Factor

Graphical representation along both the horizontal axis showing variation of drift reduction factor along the building height and the comparisons made between different cases of the buildings B1 and B2 i.e. without shear wall, with shear wall is presented from figure 5.4.1

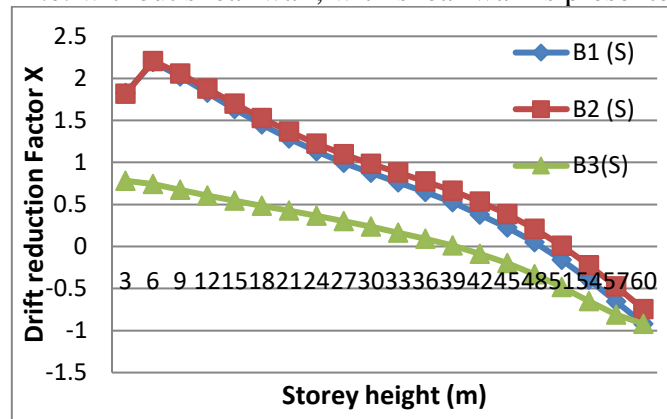

Figure 5.2.1 Comparison of Inter-storey Drift along Y axis v/s Storey Height for building B1, B2, and B3 of (G+ 19) stories

### Discussions

On the basis of comparisons, it is observed that the hit and trial method based on several parameters like location, cross section, orientation etc is a good practical approach to understand the behaviour and performance of the structure under seismic loads. Different observations of the study are summarized and shown in tabular form which is further discussed in detail in the present section.

### Inter-storey drift

Storey drift is an important aspect to be studied which directly resembles the vulnerability of pounding of a building on adjacent building in an urban area which can be a threat to human life. It indicates the possibilities of shear failure in a building. IS: 1893:2016 (Part I), recommends the maximum limit for storey drift with partial load factor of 1.0 to be 0.004 times the storey height. Hence for 3m height of each storey and load factor of 1.0 maximum permissible drift will be 12mm. It has been observed from Figures 5.2.1 to 5.2.6 that the storey drift for all the cases remains well within the permissible limit.

### Building frame with shear walls

It is also observed that the drift in the special moment resisting frame without any shear wall increases with height up to a certain level and then it decreases for both the buildings B1 and B2. The variation of storey drift with storey height in these cases for both the horizontal directions has been observed as follows:

- (1) It has been observed that in case of B1 (W) of twenty stories, the Storey drift along the horizontal X axis increases with height up to 2nd storey than from 3<sup>rd</sup> storey onwards it starts decreasing up to 20<sup>th</sup> storey. Curve along the storey height is parabolic in nature.
- (2) It has been seen that in case of B1 (W) of twenty stories, the Storey drift along the horizontal Y axis is found to negligible. There is no Curve along the storey height.
- (3) It has been observed from that in case of B2 (W) of twenty stories, the Storey drift along the horizontal X axis increases with height up to 2nd storey than from 3<sup>rd</sup> storey onwards it starts decreasing up to 20<sup>th</sup> storey. Curve along the storey height is parabolic in nature.



- (4) We found some amount of Inter-storey drift along the horizontal Y axis and it increases with height up to 2nd storey than from 3<sup>rd</sup> storey onwards it starts decreasing up to 20<sup>th</sup> storey. So, it is evident from above that the Irregular configuration of a building can put impact upon the response parameter.
- (5) In case of B3 (W) of twenty stories, the Storey drift along the horizontal X axis increases with height up to 6th storey than from 7<sup>th</sup> storey onwards it starts decreasing up to 20<sup>th</sup> storey. Curve along the storey height is parabolic in nature.
- (6) It is interesting to observe from Table 3, that in case of B3 (W) of twenty stories which is an irregular building in terms of grid formation of column and beams, we found some amount of Inter-storey drift along the horizontal Y axis and it increases with height up to 6th storey than from 7<sup>th</sup> storey onwards it starts decreasing up to 20<sup>th</sup> storey. So, it is evident from above that the Irregular configuration of a building can put impact upon the response parameter.

#### **Building frame with shear walls**

It has been observed that the story drift remains well within the permissible limit for B1 (S) and B2 (S) for twenty storied building. It is also observed that the drift in the special moment resisting frame with shear wall up to full height increases with height up to a certain level and then it decreases or remains constant for the buildings B1 and B2. The variation of storey drift with storey height in these cases for both the horizontal directions has been observed as follows:

- (1) It has been observed from Table 3, that in case of B1 (S) of twenty stories, the Storey drift along the horizontal X axis increases with height up to 14th storey than from 15<sup>th</sup> storey onwards it starts decreasing up to 20<sup>th</sup> storey. Curve along the storey height is parabolic in nature.
- (2) It is seen that in case of B1 (S) of twenty stories, the Storey drift along the horizontal Y axis is found to negligible. There is no Curve along the storey height.
- (3) It has been observed from Table 4, that in case of B2 (S) of twenty stories, the Storey drift along the horizontal X axis increases with height up to 14th storey than from 15<sup>th</sup> storey onwards it starts decreasing up to 20<sup>th</sup> storey. Curve along the storey height is parabolic in nature.
- (4) It has been observed from Table 1, that in case of B2 (S) of twenty stories, the Storey drift along the horizontal Y axis is found to negligible. There is no Curve along the storey height.
- (5) It has been observed from the Table 6 that in case of B3 (S) of twenty stories, the storey drift along the X axis increases gradually with height up to 18<sup>th</sup> storey then remains constant up to the 19<sup>th</sup> storey and then it decreases at the 20<sup>th</sup> storey. Storey drift along the Y axis increases gradually up to the full height of the building.
- (6) It can be observed from above Table, that the utilization of shear wall for both the configuration i.e, Regular as well as Irregular configuration helps in Reducing the story drift up to a greater extent.
- (7) It can also be observed from tables above, that for buildings without shear wall the values of inter storey drift for Irregular building B2 (W) is greater than the inter storey drift for Regular building B1 (W) along X axis, hence it can be interpreted that the configuration of a building effects the response parameters, so a regular configuration of a building is better option for greater performance of a building.

- (8) For building with shear wall the values of inter storey drift for Regular building B1 (S) is found to be greater than the inter storey drift for Irregular building B2 (S) along X axis, which clearly signify that the if shear wall is placed at a perfect location, it can help in giving strength to a building having Irregular configuration.
- (9) Values of Inter-storey drift along Y axis is also observed for building B2 of L shape and B3 having irregular configuration for both the cases i.e. with shear wall and without shear wall, although values of Inter-storey drift is well within permissible limit and also very negligible as compared to values along X axis but it is evident that the irregular configuration of building impacts the response parameters along the Y axis also.

### **Design Base Shear**

Design Base shear is the total horizontal resisting force action by the structure which is calculated on the basis of total seismic mass of the structure, fundamental period of vibration for a corresponding mode shape. From the comparison of total base shear for different cases of with and without shear wall for twenty storied buildings presented in Figure 5.4.1. It has been observed that the design base shear for building having shear wall is greater than the building without shear wall for both the buildings. This may be due to the fact that the shear wall adds to the modal weight of the structure which increases the stiffness of the structure. The observation of the result is summarized in the present section.

- (1) Building B1 without shear wall is having higher design base shear as compared to design base shear of B2 building, this may be due to the fact that the B2 building is having less area as compared to B1 building.
- (2) Building B1 with shear wall B1(S) is having higher design base shear as compared to design base shear of B2 building with shear wall B2(S), this may be due to the fact that the B2 building is having less area as compared to B1 building.
- (3) The design base shear for Building B3 is greater than the design base shear for building B1 and B2 without shear wall, it may be due to the fact that the Building B3 is having larger cross section of the beams and columns as compared to the building B1 and B2, this increases the modal weight of the structure which increases the stiffness of the structure, so it is evident that the shear wall helps in resisting earthquake load.
- (4) The design base shear for Building B1, B2 and B3 with shear wall is greater than the design base shear for respective building without shear, it may be due to the fact that the shear wall adds to the modal weight of the structure which increases the stiffness of the structure, so it is evident that the shear wall helps in resisting earthquake load.

### **6. Conclusion**

In view of the study carried out on one building, it is difficult or not fair to give generalized conclusions. However, following are some conclusions made from the study:-

1. It is observed that the storey drift is well within the permissible limits for all the cases.
2. Provision of shear wall has helped in reducing the storey drift for Regular building having rectangular shape as well as for irregular building having L shape configuration and for irregular building having irregular grid formation for beams and columns.
3. Buildings having shear wall has shown lesser values of storey drift as compared to buildings without any shear wall.

4. It is observed that the drift in the special moment resisting frame with shear wall up to full height increases with height up to a certain level and then it decreases or remains constant for the both the buildings B1 and B2.
5. It is evident from above that the Irregular configuration of a building can get inter-storey drift along both the horizontal axis, so it is a better option to provide shear wall along both the axis, and also position of shear wall in a building has greater impact on various parameters.
6. It has been observed that the design base shear for building having shear wall is greater than the building without shear wall for both the buildings, it may be due to the fact that the shear wall adds to the modal weight of the structure which increases the stiffness of the structure, so it is evident that the shear wall helps in resisting earthquake load.
7. Hit and trial method based on several parameters like location, cross section, orientation etc is a good practical approach to understand the behaviour and performance of the structure under seismic loads.

#### **7. References**

- [1].B, SanganiSanikumar. And Prajapati, G. I. (2013), "Structural Economics of Earthquake resistant design of RC building with and without shear wall", ICI journal, April- June.
- [2].Malik,R.S., Madan,S.K. and Sehgal, V.k. (2011), "Effect of height on seismic response of reinforced cement concrete framed buildings with curtailed shear wall", Journal of Engineering and Technology, Vol. (1), Issue. (1), Jan-June.
- [3].Gupta, U.,Ratnaparkhe, S.andGome, P. (2012), "Seismic Behaviour of Buildings having flat slabs with drops", International Journal of Emerging Technology and Advanced Engineering, Vol. (2), Issue. (10), Oct.
- [4].Harne,Varsha R. (2013), "Comparative study of strength of RC shear wall at different location on multi-storied residential building", International Journal of Civil Engineering Research, Vol. (5), No. (4), pp.391-400.
- [5].Sardar, S.J. and Karadi, U.N. (2013), "Effect of change in shear wall location on storey drift of multi-storey building subjected to lateral loads", International Journal of Innovative Research in Science, Vol. (2), Issue. (9), Sept.
- [6].Chandurkar,P.P. andPajgade,P.S. (2013), "Seismic Analysis of RCC building with and without Shear wall", International Journal of Modern Engineering Research, Vol. (3), Issue (3), pp.1805-1810, May- June.
- Esmaili, O.,Epackachi,S.,Samadzad, M. and Mirghaderi,S.R. (2008), "Study of structural RC shear wall system in a 56-story RC tall building", Proceedings of the 14<sup>th</sup> world conference on earthquake engineering, Beijing, China , October 12-17.
- [7].Misam, A. and Magulkar,Madhuri N. (2012), "Structural response of soft story high rise buildings under different shear wall location", International journal of civil engineering and technology, Vol. (3), Issue (2), pp.169-180.
- [8].Venkata, S.K.N, Krishna, Sai M.L.N., Satynarayana, S. V. (2013), "Influence of reinforced concrete shear wall on multi-storeyed buildings", International Journal of Engineering Sciences & Research Technology, Vol. (2), Issue (8), pp.2055-2060.
- [9].Venkatesh,S.V. and Bai,H. Sharada."Effect of internal & External shear wall on performance of buildings frame subjected to lateral load", International Journal of Earth Science and Engineering, Vol. (4), No. (6), pp.571-576.

- [10]. Dasgupta, K. (2007), "Seismic Design of slender reinforced concrete structural walls", Proceedings of first IITK REACH symposium at Parwanoo, March 2007, IIT Kanpur, Vol. 8, No. 2, December.
- [11]. Medhekar, M.S. and Jain, S.K. (1993), "Seismic behaviour design and detailing of RC shear wall", Part II: Design and detailing", The Indian Concrete Journal, Sept.
- [12]. Yoshimura, K .and Kikuchi,K. (1984), "On practical method for evaluating lateral stiffness of R/C shear walls arranged irregularly into ductile moment resisting frames", Proceedings of the 8<sup>th</sup> world conference on earthquake engineering, San Francisco, California.
- [13]. Greeshma S. and Jaya K.P. (2008), "Seismic behaviour of shear wall-Slab connection", Proceedings of the 14<sup>th</sup> world conference on earthquake engineering, Beijing, China, October 12-17.
- [14]. Madan, S.K., Malik,R.S. and Sehgal,V.K. (2015), "Seismic evaluation with shear walls and braces for buildings", World academy of Science, Engineering and Technology, International Journal of Civil, structural, construction and Architectural Engineering, Vol. (9), No. (2).

---

## **Effect of Shear Wall in Building Having Irregular Configuration: An Overview**

**Ms. Sameeksha\***

**Dr.Harpal Singh\*\***

### **Abstract**

*Inferable from the expanding shortage and cost of land, structural engineers are being headed to embrace the vertical development of structures. This need keeps on testing specialists to achieve new height and this progression of increasing height of structures gets more challenge in the type of seismic loads. It has been seen amid past seismic tremors that structures which are regular in design perform much superior to anything those which have irregular design. In this way, it is constantly attractive to embrace a regular configuration of an elevated structure while designing; however architectural interest, customer desire and typical site condition now and again make it highly irregular in plan or irregular vertically which can affect the performance under the action of seismic load. Amid this study Two distinct instances of building (i) Regular building having rectangular configuration and (ii) Irregular building having L shape configuration is considered with a specific end goal to comprehend the behavior of an irregular building with simple moment resisting frame having beam, columns and two way slabs and to study the effect of providing shear wall on the performance of these buildings under seismic loading. Both the regular and irregular buildings are thought to be situated in zone IV. Linear dynamic analysis through Response Spectrum method is carried out utilizing the standard STAAD.PRO programming bundle. The structures are displayed for seismic prerequisite given by the Indian seismic code IS: 1893-2016 (Part 1). This paper intends to present the observations of research works carried out on building of different configuration having shear walls.*

**Key Words:** Shear wall, tall Buildings, dual structural system, base shear, story drift, Staad-pro, etc.

### **1. Introduction**

An earthquake might be characterized as the release of elastic energy by a sudden slip on a fault and coming about ground shaking and transmitted caused by slip. It is a standout amongst the most devastating natural hazards normal perils that reason extraordinary death toll and livelihood. The greater part of the misfortunes is because of building collapse or damages. An Earthquake can cause harm not just by virtue of vibrations which comes about because of them yet in addition because of other chain impacts like landslides, surges, fires, and so on. An extensive structural analysis of a tall building is dependably a mind boggling undertaking, particularly for a high rise building having plan irregularities. For an irregular building having plan irregularities, it is important to use the dynamic method of analysis to get the reaction parameters. For sure, the reaction of any building under the action of seismic forces is exceptionally complex and Response spectrum method of analysis ends up being a superior choice to acquire the reaction of the structure

---

\* C.E student, Civil Engineering Department, Guru Nanak Dev Engineering College Ludhiana, Punjab, India

\*\* Professor, Civil Engineering Department, Guru Nanak Dev Engineering College Ludhiana, Punjab, India



under the activity of seismic forces. Besides, the important earthquake resistant ability in a multi-storied building can be accomplished by giving sufficient stiffness, strength and ductility in the building and shear wall gives an ideal mean for accomplishing the fundamental criteria of design [T. Paulay and M.J.N Priestley, 1992]. The information gained through the test and systematic discoveries on shear wall through the course of time, furthermore the comprehension of the seismic response of shear wall has made it conceivable to utilize it proficiently in high rise buildings to oppose earthquake loads. Shear wall is a component which goes about as a vertical cantilever utilized for the most part in multi storied buildings to oppose horizontal forces like wind, storm, and seismic earthquake. These walls are when all is said in done continuous component beginning from the foundation and go up to the most elevated point of the building. In any case, it might likewise be curtailed at middle height. Shear wall can oppose the blend of shear, moment and axial load incited by lateral load and gravity load exchanged to it through other structural members. At the point when shear wall is utilized alongside moment resisting frame in a structure, it is called dual structural framework and in this framework the loads are opposed by both frame and Shear walls. The contribution of Shear wall in opposing overturning moments, story shear and story shear forces relies on the geometric configuration, materials utilized, orientation and location inside the plane of the building [T. Paulay and M.J.N Priestley, 1992].

### **1.1 Action of shear wall in resisting loads**

Utilization of shear walls gives an effective solution to stiffen a structural system of a building as it increases the rigidity against horizontal load acting up on the building. Shear wall essentially increases the stiffness and strength of the building toward its orientation. This results in reduction of lateral sway in the building. By and large the Shear wall transfers the load to the next component beneath it in the load path. It helps in reducing the side sway of the above individuals like roof or floor. It also keeps the floor and roof framing individuals from moving off their supports when they are stiffened enough and furthermore diminishes the non structural damages [2].

### **1.2 Failures in shear wall**

Seismic response of a multi-storied building generally depends upon the distribution of mass, stiffness and strength in horizontal and longitudinal direction of the building. In earthquake resistant design of a building the main focus is laid upon providing structural safety against the lateral load in order to avoid total collapse of the building during an earthquake. As per the past experiences following are the failures observed in RC shear walls [1]:-

1. Failures due to plastic hinge formation which takes place over a region (normally at the base of the wall) due to excessive cracking of concrete & yielding of steel.
2. Shear failure of the wall due to following five different modes:-
  - a. Shear failure from plastic hinge action
  - b. Crushing due to diagonal compression
  - c. Tensile failure of vertical steel
  - d. Crushing of concrete due to vertical compression
  - e. Sliding shear failure along horizontal cracks

### **2. Objective of Studies**

Main objective of the present work is to evaluate the performance of an RC building having plan irregularities using response spectrum method of analysis to study the effect of



providing shear wall on the performance of the building under seismic loading in seismic zone IV.

[1] Structural analysis of four different cases of a G+19 building with and without shear wall in seismic zone IV of India, having different configurations viz. (i) Regular building having rectangular configuration and (ii) Irregular building having L shape configuration

[2] Working out the Moment, Storey drift, Lateral displacement and Base shear.

[3] Comparing the response parameters to study the effect of irregular configuration on the performance of building under the action of earthquake load and also the effect of providing shear wall in seismic zone IV.

### **3. Methodology**

A building is said to be irregular if it possesses plan irregularities (if structural elements cannot be arranged in proper grid) or vertical irregularities, which is due to the presence of soft story in high rise buildings [as per clause 7.1, IS 1893 Part (I)]. This work aims to study the seismic performance of the dual structural system of tall buildings having plan irregularities, which essentially comprises of analysis and comparison of response parameters of the building having regular configuration of rectangular shape without shear wall, with shear wall, irregular building having L shape configuration without shear wall and with shear wall subjected to earthquake loading.

In this attempt, following major works will be accomplished:-

[1] Considering four different cases of building having regular and irregular configuration with shear wall and without shear wall.

[2] Deciding the design parameters such as size of columns, beams, shear wall, etc. as per the guidelines of IS 1893:2016 (Part 1).

[3] Modelling of various structures.

[4] Carrying out detailed analysis of bare frame models and dual structural system with shear wall

[5] Plotting curves between storey height vs inter-storey drift, base shear, etc.

### **Description of the structure**

A building having regular configuration of rectangular shape and a building having irregular configuration of L shape is considered to prepare various three dimensional bare frame model and shear wall-frame model of the building. The building is having a typical floor height of 3 meters. The structure will be analyzed for seismic loads using STAAD.PRO software package.

The following assumptions are considered for the dynamic analysis.

[1] All supports are assumed to be fixed.

[2] Un-cracked sections for beams and columns are used in the analysis.

[3] Shear deformation effects are neglected.

[4] The floor diaphragms are rigid enough to distribute uniformly the lateral loads on the vertical elements.

[5] The out of the plane deformations are absorbed by rigid horizontal diaphragms.

### **Modeling approach**

The modeling approach includes the preparation of a centerline plan of the irregular building to obtain the coordinates of various joints followed by specifying the nodal coordinates data for the development of model using STAAD.PRO.

### **Analysis procedure**

IS 1893(Part I): 2016 recommends the method of dynamic analysis for the following:-

[a] Regular buildings- those higher than 40 meters in height in seismic zone IV and V, and those higher than 90 meters in Zone II and III.

[b] Irregular buildings- all framed buildings higher than 12 meters in zone IV and V, and those higher than 40 meters in zone II and III.

As per the code recommendation, dynamic method of analysis has been adopted for the analysis of building. The main purpose of the dynamic analysis is to obtain the design seismic forces, followed by its distribution to different levels along the height of the building and to various lateral load resisting elements. There are various methods for the dynamic analysis of a building, out of them Response spectrum method has been chosen for the analysis.

### Response Spectra Method

The main purpose of the response spectrum analysis is to obtain the design seismic forces, with its distribution to different storey levels along the height of the building and to the various lateral load resisting elements. This method is based on the assumption that the dynamic response of the structure may be found by considering the independent response of each natural mode of vibration and then combining in the same way to compute the total response.

The first step in the analysis by the response spectrum method is determining the lumped masses at the floor level due to dead load and appropriate amount of live load. Then the free vibration analysis of entire building shall be performed as per established methods of mechanics using the appropriate masses and elastic stiffness of the structural system, to obtain natural time period (T) and mode shapes ( $\phi$ ). The CL. 7.8.4.2 of IS 1893:2002 gives a guideline for the number of modes to be considered. As per the clause the number of modes to be considered in the analysis should be such that the sum of modal masses of all modes considered is at least 90 percent of the total seismic mass. If modes with natural frequency 33 Hz are to be considered, modal combination should be carried out only for modes up to 33 Hz. The effect of modes with natural frequency beyond 33 Hz shall be included by considering the missing mass correction. As per CL. 7.8.4.5 buildings with regular and nominal irregular plan configuration may be modelled as a system of masses lumped at the floor levels with each mass having one degree of freedom, which is the lateral displacement in the direction under consideration. After satisfying the above condition the modal mass is calculated using the expression given in the code,

$$M_k = \frac{[\sum_{i=1}^n W_i \phi_{ik}]^2}{g \sum_{i=1}^n W_i (\phi_{ik})^2}$$

Where  $M_k$  is the modal mass of mode k, g is acceleration due to gravity,  $\phi_{ik}$  is mode shape coefficients of floor i in mode k and  $W_i$  is the seismic weight of floor i. The percent mass contributing in each mode is calculated and if the total percent of mass is less than 90% of total seismic mass, either the number of modes should be increased up to 33 Hz or missing mass correction should be applied.

Now the design lateral force at each mode is calculated by the formula, given in CL.7.8.4.5(c), of IS 1893 (part I):2002

$$Q_{ik} = A_k \phi_{ik} P_k W_i$$

Where  $A_k$  is design horizontal acceleration spectrum value obtained using natural period of vibration ( $T_k$ ) of mode k,  $P_k$  is the modal participation factor of mode k and is given by,

$$P_k = \frac{\sum_{i=1}^n W_i \phi_{ik}}{\sum_{i=1}^n W_i (\phi_{ik})^2}$$

The peak storey shear ( $V_{ik}$ ) acting in storey  $i$  in mode  $k$  is given by,

$$V_{ik} = \sum_{j=i+1}^n Q_{ik}$$

The peak storey shear force ( $V_i$ ) in storey  $i$  due to all modes considered is obtained by combining those due to each mode. Code has given various methods for combining the peak response quantities (for eg. Member forces, displacements, storey force, storey shears and base reactions). The complete quadratic combination (CQC) should be used when the modes are well separated or when modes are closely spaced.

$$\lambda = \sqrt{\sum_{i=1}^r \sum_{j=1}^r \lambda_i \rho_{ij} \lambda_j}$$

Where  $r$  is the number of modes being considered  $\lambda_i$  is the response quantity in mode  $i$  (including sign),  $\lambda_j$  is the response quantity in mode  $j$  (including sign) and  $\rho_{ij}$  is cross-modal coefficient given by,

$$\rho_{ij} = \frac{8 \zeta^2 (1 + \beta) \beta^{1.5}}{(1 - \beta^2)^2 + 4 \zeta^2 \beta (1 + \beta)^2}$$

$\zeta$  = Modal damping ratio (in fraction) as specified in 7.8.2.1,

$\beta$  = Frequency ratio =  $\omega_j / \omega_i$

$\omega_i$  = Circular frequency in  $i^{\text{th}}$  mode, and

$\omega_j$  = Circular frequency in  $j^{\text{th}}$  mode.

But when the building does not have closely spaced modes, square root of squares (SRSS) method should be used, then the peak response quantity ( $\lambda$ ) due to all modes considered shall be obtained as,

$$\lambda = \sqrt{\sum_{k=1}^r (\lambda_k)^2}$$

Where,

$\lambda_k$  = Absolute value of quantity in mode  $k$ , and

$r$  = Number of modes being considered

When the building has few closely spaced modes then peak response quantities ( $\lambda^*$ ) due to these modes shall be obtained as,

$$\lambda^* = \sum_c^r \lambda_{c'}$$

When the summation is for closely spaced modes only, this peak response quantity due to closely spaced modes ( $\lambda^*$ ) is then combined with those of remaining well separated modes by CQC method as described above.

After combining the peak storey shear ( $V_{ik}$ ), the design lateral force at roof and floor level is obtained as per clause 7.8.4.5 (f) of IS 1893 (part I): 2002 as,

$$F_{roof} = V_{roof}$$
$$F_i = V_i - V_{i+1}$$

Code has also introduced a lower bound on seismic forces (Cl.7.8.2), this clause requires that in case of dynamic analysis gives lower seismic forces, these to be scaled up to the level of forces obtained based on empirical fundamental period  $T_a$ .

#### **4. Problem Formulation & Analysis Procedure**

Main objective of the present work is to evaluate the performance of an RC building having plan irregularities using response spectrum method of analysis to study the effect of providing shear wall on the performance of the building under seismic loading in seismic zone IV. The specific aims and objectives of the project is the structural analysis of four different cases of a G+19 building with and without shear wall in seismic zone IV of India, having different configurations viz.

1. Regular building having rectangular configuration without shear wall.
2. Regular building having rectangular configuration with shear wall.
3. Irregular building having L shape configuration without shear wall.
4. Irregular building having L shape configuration with shear wall.

Different models are prepared for all the buildings having different configuration of shear wall as mentioned above for G+19 stories. All the cases are assumed to be located in Zone IV. Shear walls in the outermost frame panels are considered in order to study the effect of provision of the shear wall under the action of earthquake force. To study the behaviour, response parameters selected are Storey drift, Lateral displacement, Base shear and Drift reduction factor.

#### **Loadings and Factors Considered**

[1] Dead load on all the floors- 4 KN/m<sup>2</sup>

[2] Live load on typical floor- 4 KN/m<sup>2</sup>

[3] Zone factor = 0.36 (for zone iv)

[4] Importance factor = 1

[5] Response reduction factor = 5

[6] Damping = 5 %

[7] Medium soil site

#### **Load combinations**

Load combinations considered for the dynamic analysis are as follows:

8. 1.5(DL+LL)

9. 1.2(DL+LL+EL)

10. 1.2(DL+LL-EL)

11. 1.5(DL+EL)

12. 1.5(DL-EL)

13. 0.9DL+1.5 EL

14. 0.9DL-1.5 EL

## Details of the Cases

### Details of case I

B1 is rectangular shape building having regular configuration, analysed here as a separate building of G+19 stories, termed as B1-W.

The area of the building = 40 m X 25 m

Typical story height = 3m

Bay along X axis= 5m

Bay along Y axis = 5m

Size of beam throughout the height of the building = 300mmx500mm

Size of Column = 300mmx500mm

Thickness of slab = 120mm

Shear wall is not provided

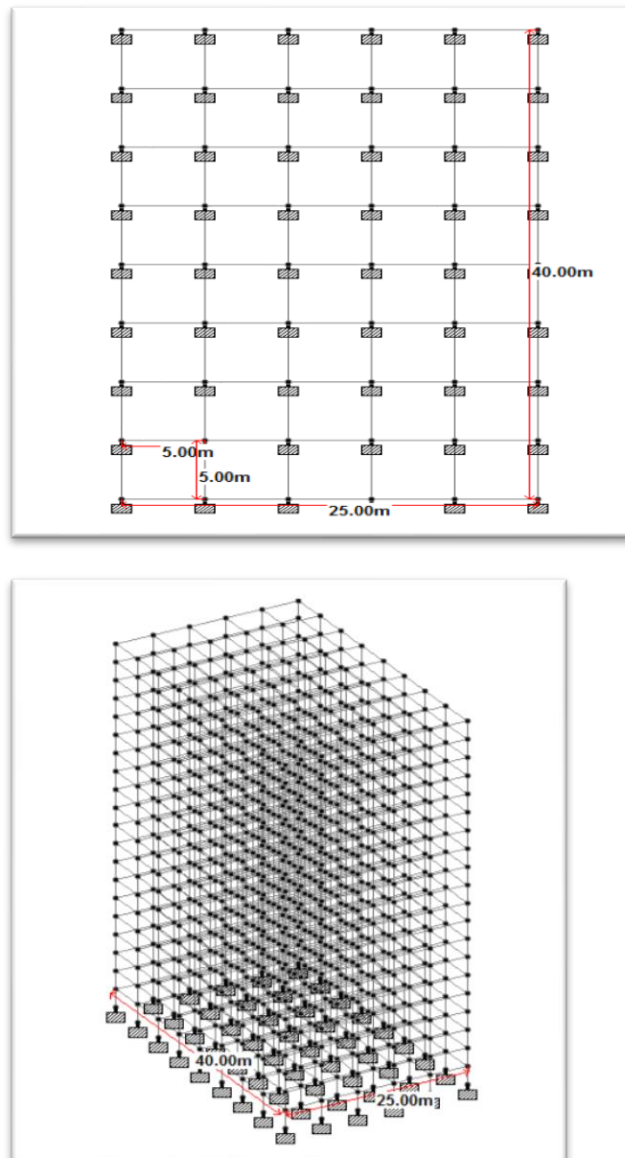

**Figure 4.6.1.1 – Plan and Isometric view of CaseI**



### Details of Case II

B1 is rectangular shape building having regular configuration, analysed here as a separate building of G+19 stories, termed as B1-S.

The area of the building = 40 m X 25 m

Typical story height = 3m

Size of beam throughout the height of the building = 300mmx500mm

Size of Column = 300mmx500mm

Thickness of slab = 120mm

Thickness of Shear wall = 300mm

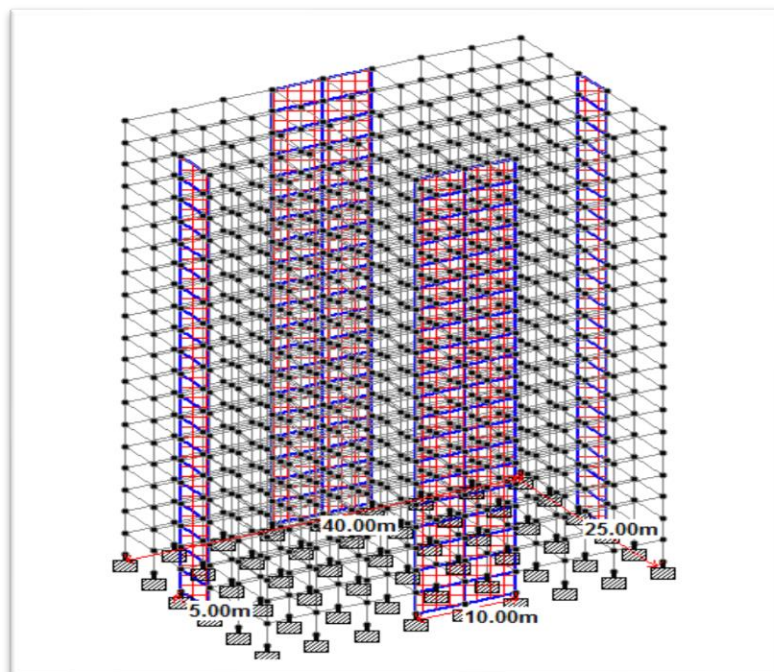
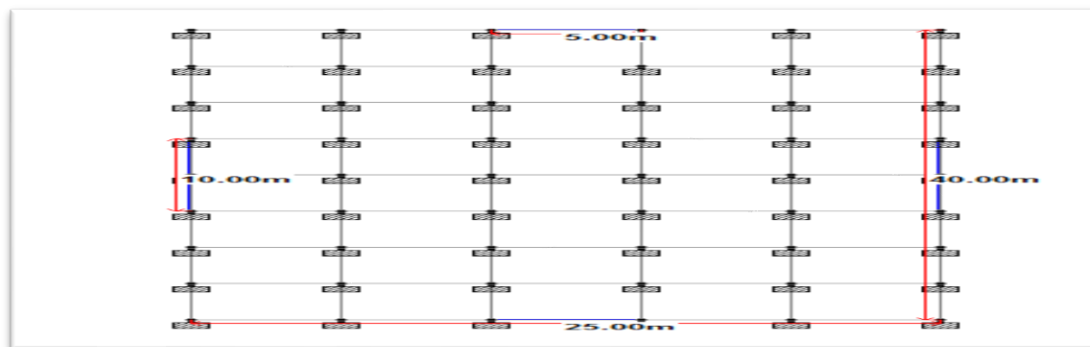

Figure 4.5.2.1 – Plan and Isometric view of CaseII

### Details of Case III

B2 is L shape building having irregular configuration, analyzed here as a separate building of G+19 stories, termed as B2-W.

The area of the building = 40 m X 25 m

Typical story height = 3m

Bay along X axis= 5m



Bay along Y axis = 5m

Size of beam throughout the height of the building = 300mmx500mm

Size of Column = 300mmx500mm

Thickness of slab = 120mm

Shear wall is not provided

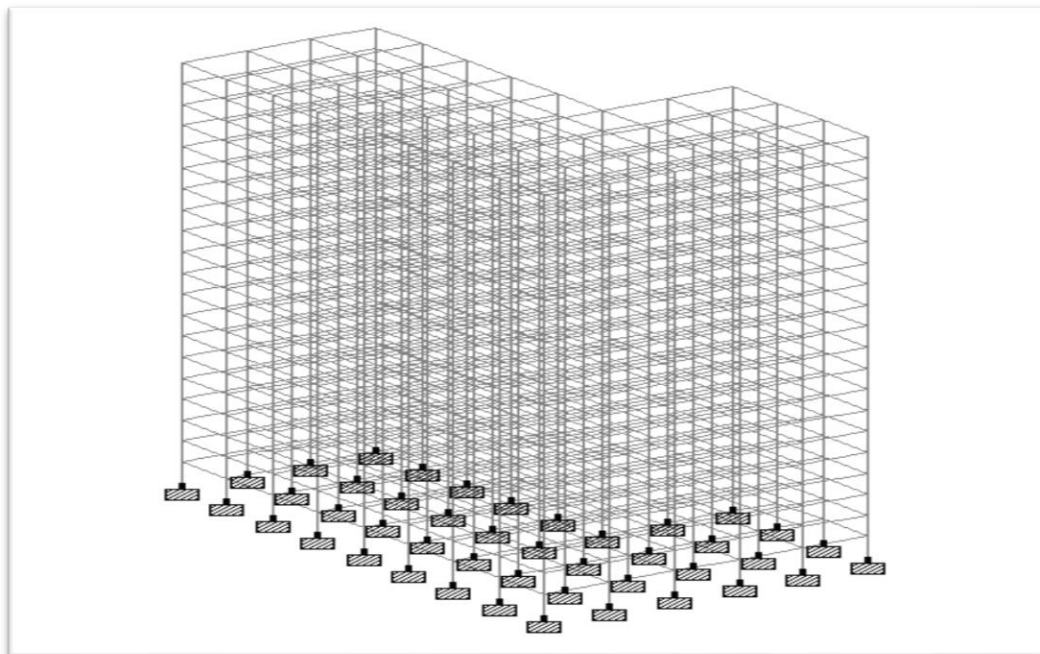
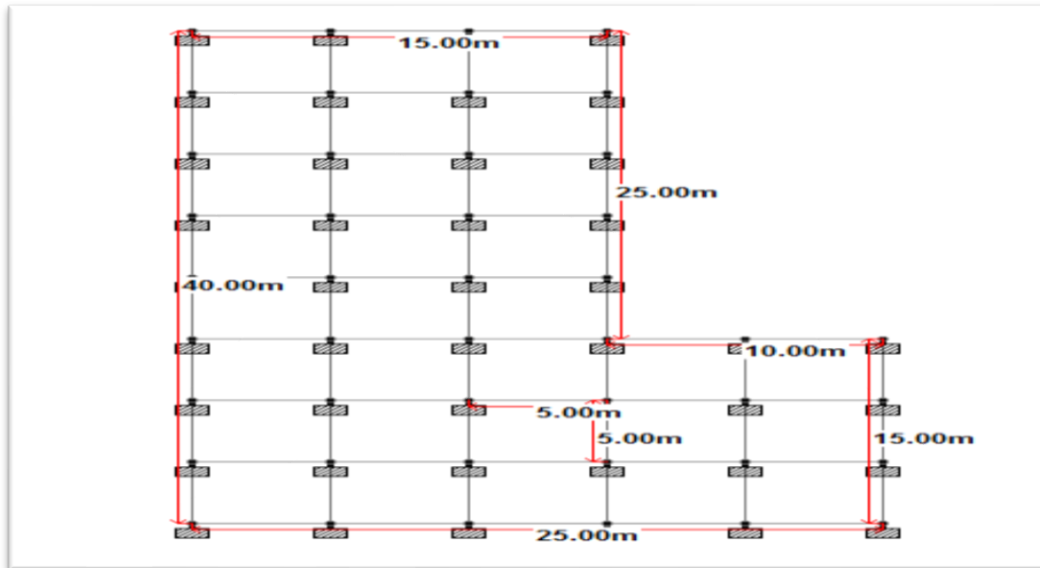

Figure 4.5.3.1 – Plan and Isometric view of CaseIII

#### Details of Case IV

B2 is L shape building having irregular configuration, analyzed here as a separate building of G+19 stories, termed as B2-S.

The area of the building = 40 m X 25 m

Typical story height = 3m

Size of beam throughout the height of the building = 300mmx500mm

Size of Column = 300mmx500mm

Thickness of slab = 120mm

Thickness of Shear wall = 300mm

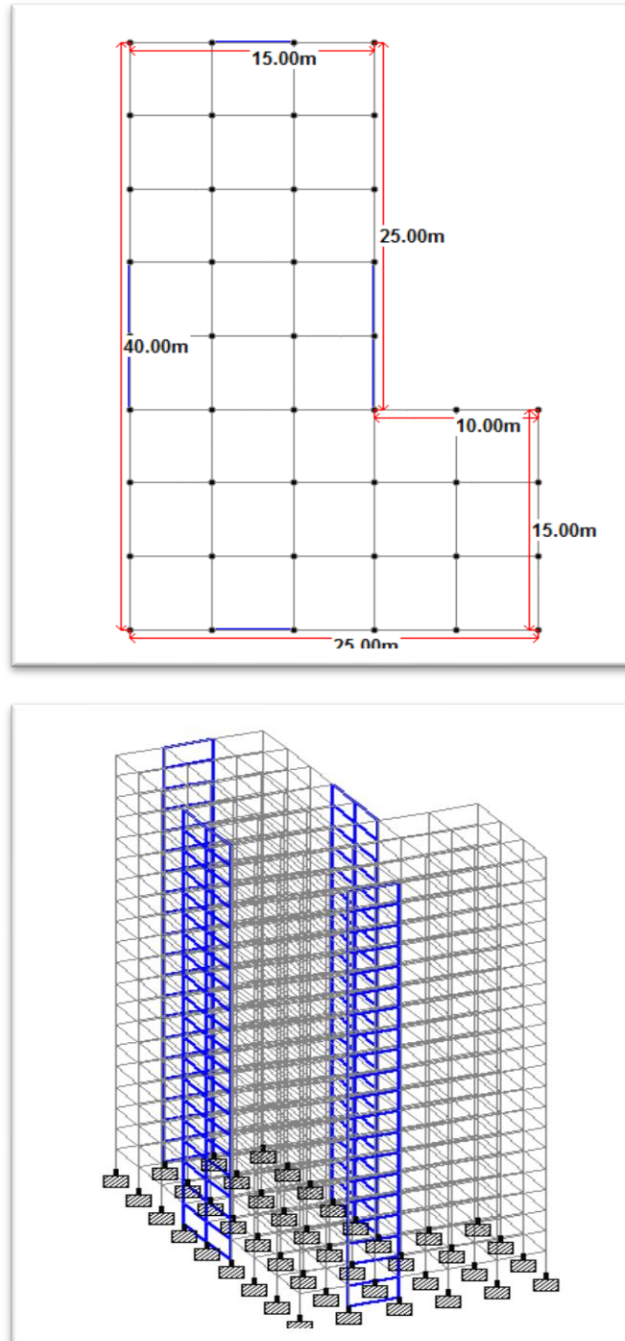

**Figure 4.5.4.1 – Plan and Isometric view of CaseIV**

## **5. Results and Discussion**

### **Effect on Storey Drift along the Building Height**

Graphical representation showing variation of storey drift along the building height and the comparisons made between different cases of the buildings B1 and B2i.e. Without shear

wall, with shear wall is presented from figure 5.2.1 to 5.2.4. Permissible storey drift in every case is 0.004 times the story height i.e.  $0.004 \times 3000\text{mm} = 12\text{mm}$ .

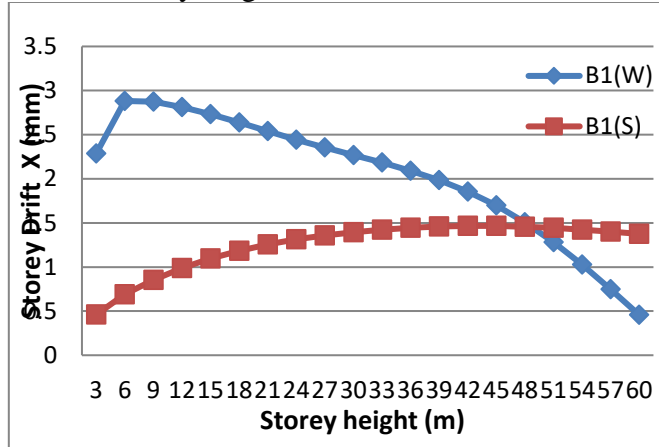

Figure 5.2.3 Comparison of Inter-story Drift along X axis v/s Storey Height for Regular building B1 of Rectangular shape of (G+19) stories

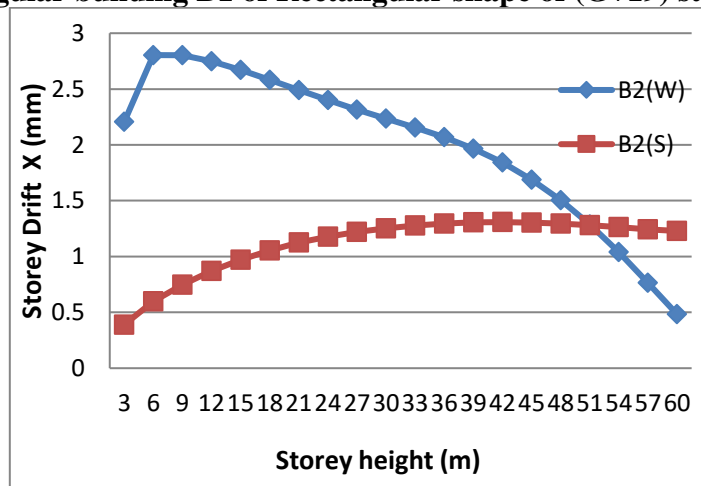

Figure 5.2.3 Comparison of Inter-story Drift along X axis v/s Storey Height for irregular building B2 of L shape of (G+19) stories

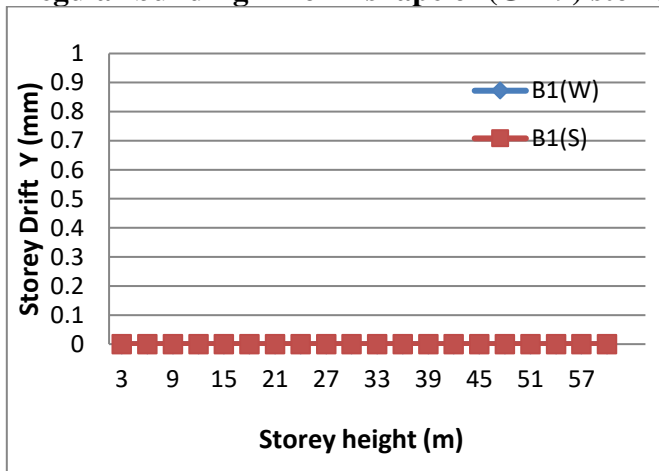

Figure 5.2.3 Comparison of Inter-story Drift along Y axis v/s Storey Height for Regular building B1 of Rectangular shape of (G+19) stories

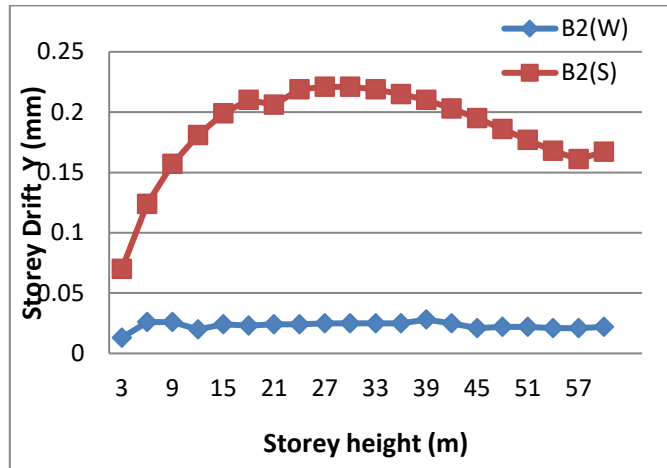

Figure 5.2.3 Comparison of Inter-story Drift along X axis v/s Storey Height for irregular building B2 of L shape of (G+19) stories

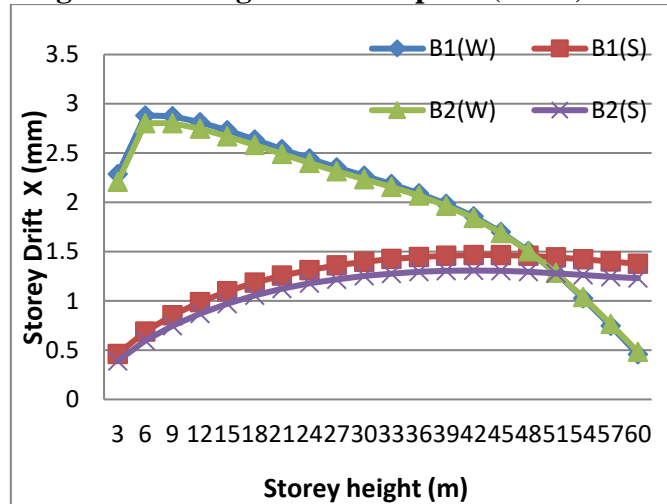

Figure 5.2.3 Comparison of Inter-story Drift along X axis v/s Storey Height for different cases of the building B1 and B2 of (G+19) stories

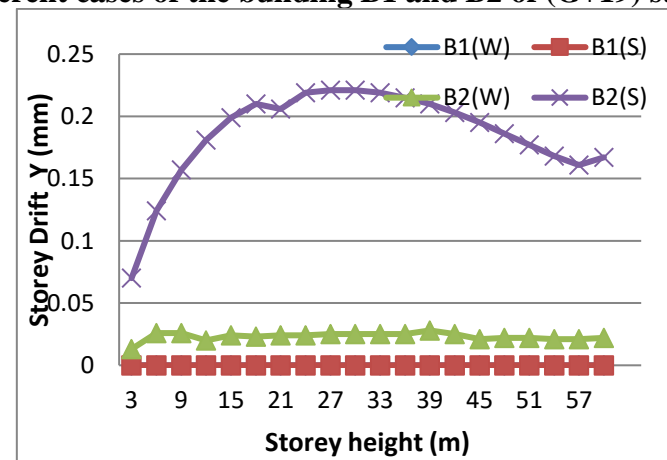
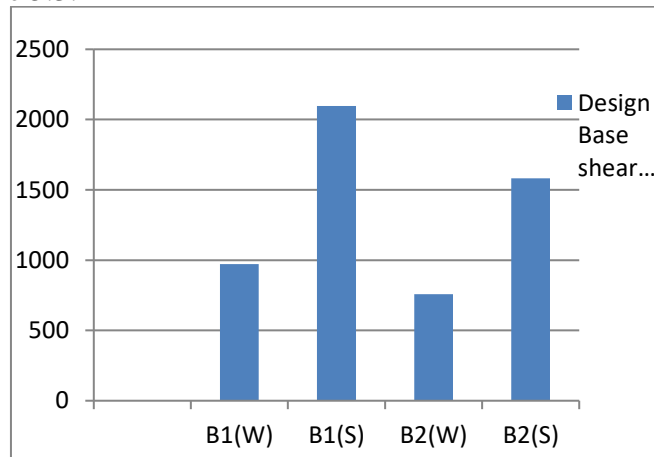

Figure 5.2.3 Comparison of Inter-story Drift along Y axis v/s Storey Height for different cases of the building B1 and B2 of (G+19) stories

### Effect on Design Base Shear

Graphical representation showing variation of Base shear and the comparisons made between different cases of the buildings B1 and B2 i.e. without shear wall, with shear wall is presented in figure 5.3.1



**Figure 5.3.1 Comparison of Base shear for different cases of the buildings B1 and B2 of (G+19) stories**

### Effect on drift reduction factor along the height

Graphical representation along the horizontal axis, showing variation of drift reduction factor along the building height and the comparisons made between different cases of the buildings B1 and B2 i.e. without shear wall, with shear wall is presented from figure 5.4.1

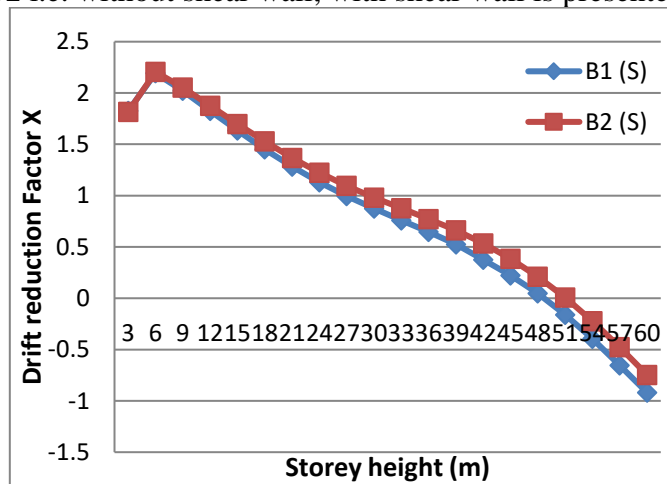

**Figure 5.2.3 Comparison of Drift reduction factor along X axis v/s Height for different cases of the buildings B1 and B2 of (G+19) stories**

### Discussions

On the basis of comparisons, it is observed that the hit and trial method based on several parameters like location, cross section, orientation etc is a good practical approach to understand the behaviour and performance of the structure under seismic loads. Different observations of the study are summarized and shown in tabular form which is further discussed in detail in the present section.

### Inter-storey drift

Storey drift is an important aspect to be studied which directly resembles the vulnerability of pounding of a building on adjacent building in an urban area which can be a threat to

human life. It indicates the possibilities of shear failure in a building. IS: 1893:2016 (Part D), recommends the maximum limit for storey drift with partial load factor of 1.0 to be 0.004 times the storey height. Hence for 3m height of each storey and load factor of 1.0 maximum permissible drift will be 12mm. It has been observed from Figures 5.2.1 to 5.2.6 that the storey drift for all the cases remains well within the permissible limit.

**Building frame with shear walls**

Considering the importance of storey drift in a building it has been observed from the figures 5.2.1 to 5.2.8, that the story drift remains well within the permissible limit for B1(W) and B2 (W) for twenty storied building. It is also observed that the drift in the special moment resisting frame without any shear wall increases with height up to a certain level and then it decreases for both the buildings B1 and B2.

**Table 1: Variation of Inter-Story Drift along X axis for different cases of the buildings B1 and B2of (G+19) stories**

Story Height	B1(W) Regular building of rectangular shape without shear wall	B2(W) Irregular building of L shape without shear wall	B1(S) Regular building of rectangular shape with shear wall	B2(S) Irregular building of L shape with shear wall
3	2.285	2.207	0.46	0.39
6	2.882	2.804	0.689	0.598
9	2.875	2.802	0.854	0.747
12	2.814	2.747	0.988	0.87
15	2.731	2.67	1.097	0.971
18	2.637	2.582	1.185	1.054
21	2.54	2.491	1.256	1.125
24	2.444	2.4	1.313	1.177
27	2.354	2.316	1.359	1.219
30	2.269	2.235	1.395	1.253
33	2.184	2.155	1.424	1.277
36	2.092	2.068	1.445	1.295
39	1.985	1.966	1.459	1.305
42	1.856	1.842	1.466	1.308
45	1.697	1.689	1.465	1.304
48	1.506	1.504	1.457	1.295
51	1.282	1.287	1.443	1.28
54	1.027	1.039	1.423	1.262
57	0.747	0.765	1.401	1.243
60	0.457	0.483	1.377	1.23

- (i) It can be observed from Table 5, that the utilization of shear wall for both the configuration i.e, Regular as well as Irregular configuration helps in Reducing the story drift up to a greater extent.
- (ii) It can also be observed from Table 5, that for buildings without shear wall the values of inter storey drift for Irregular building B2 (W) is greater than the inter storey drift for Regular building B1 (W)along X axis, hence it can be interpreted that the



configuration of a building effects the response parameters, so a regular configuration of a building is better option for greater performance of a building.

(iii) For building with shear wall the values of inter storey drift for Regular building B1 (S) is found to be greater than the inter storey drift for Irregular building B2 (S) along X axis, which clearly signify that the if shear wall is placed at a perfect location, it can help in giving strength to a building having Irregular configuration.

**Table 2: Variation of Inter-Story Drift along Y axis for different cases of the buildings B1 and B2 of (G+19) stories**

Story Height	B1(W) Regular building of rectangular shape without shear wall	B2(W) Irregular building of L shape without shear wall	B1(S) Regular building of rectangular shape with shear wall	B2(S) Irregular building of L shape with shear wall
3	0	0.013	0	0.07
6	0	0.026	0	0.124
9	0	0.026	0	0.157
12	0	0.02	0	0.181
15	0	0.024	0	0.199
18	0	0.023	0	0.21
21	0	0.024	0	0.206
24	0	0.024	0	0.219
27	0	0.025	0	0.221
30	0	0.025	0	0.221
33	0	0.025	0	0.219
36	0	0.025	0	0.215
39	0	0.028	0	0.21
42	0	0.025	0	0.203
45	0	0.021	0	0.195
48	0	0.022	0	0.186
51	0	0.022	0	0.177
54	0	0.021	0	0.168
57	0	0.021	0	0.161
60	0	0.022	0	0.167

From Table 2, Values of Inter-storey drift along Y axis is observed for building B2 of L shape having irregular configuration for both the cases i.e. with shear wall and without shear wall, although values of Inter-storey drift is well within permissible limit and also very negligible as compared to values along X axis but it is evident that the irregular configuration of building impacts the response parameters along the Z axis also.

**Design Base Shear**

Design Base shear is the total horizontal resisting force action by the structure which is calculated on the basis of total seismic mass of the structure, fundamental period of vibration for a corresponding mode shape. From the comparison of total base shear for different cases of with and without shear wall for twenty storied buildings presented in Figure 5.4.1. It has been observed that the design base shear for building having shear wall

is greater than the building without shear wall for both the buildings. This may be due to the fact that the shear wall adds to the modal weight of the structure which increases the stiffness of the structure. The observation of the result is summarized in the present section.

[1] Building B1 without shear wall is having higher design base shear as compared to design base shear of B2 building, this may be due to the fact that the B2 building is having less area as compared to B1 building.

[2] Building B1 with shear wall B1(S) is having higher design base shear as compared to design base shear of B2 building with shear wall B2(S), this may be due to the fact that the B2 building is having less area as compared to B1 building.

[3] The design base shear for Building B1 and B2 with shear wall is greater than the design base shear for respective building without shear wall, it may be due to the fact that the shear wall adds to the modal weight of the structure which increases the stiffness of the structure, so it is evident that the shear wall helps in resisting earthquake load.

## **6. Conclusion**

In view of the study carried out on one building, it is difficult or not fair to give generalized conclusions. However, following are some conclusions made from the study:-

1. It is observed that the storey drift is well within the permissible limits for all the cases.
2. Provision of shear wall has helped in reducing the storey drift for Regular building having rectangular shape as well as for irregular building having L shape configuration.
3. Buildings having shear wall has shown lesser values of storey drift as compared to buildings without any shear wall.
4. It is observed that the drift in the special moment resisting frame with shear wall up to full height increases with height up to a certain level and then it decreases or remains constant for the both the buildings B1 and B2.
5. It is evident from above that the Irregular configuration of a building can get inter-storey drift along both the horizontal axis, so it is a better option to provide shear wall along both the axis, and also position of shear wall in a building has greater impact on various parameters.
6. It has been observed that the design base shear for building having shear wall is greater than the building without shear wall for both the buildings, it may be due to the fact that the shear wall adds to the modal weight of the structure which increases the stiffness of the structure, so it is evident that the shear wall helps in resisting earthquake load.
7. Hit and trial method based on several parameters like location, cross section, orientation etc is a good practical approach to understand the behaviour and performance of the structure under seismic loads.

## **7. REFERENCES**

1. B, SanganiSanikumar. And Prajapati, G. I. (2013), "Structural Economics of Earthquake resistant design of RC building with and without shear wall", ICI journal, April- June.
2. Malik,R.S., Madan,S.K. and Sehgal, V.k. (2011), "Effect of height on seismic response of reinforced cement concrete framed buildings with curtailed shear wall", Journal of Engineering and Technology, Vol. (1), Issue. (1), Jan-June.
3. Gupta, U.,Ratnaparkhe, S.andGome, P. (2012), "Seismic Behaviour of Buildings having flat slabs with drops", International Journal of Emerging Technology and Advanced Engineering, Vol. (2), Issue. (10), Oct.

4. Harne, Varsha R. (2013), "Comparative study of strength of RC shear wall at different location on multi-storied residential building", International Journal of Civil Engineering Research, Vol. (5), No. (4), pp.391-400.
5. Sardar, S.J. and Karadi, U.N. (2013), "Effect of change in shear wall location on storey drift of multi-storey building subjected to lateral loads", International Journal of Innovative Research in Science, Vol. (2), Issue. (9), Sept.
6. Chandurkar, P.P. and Pajgade, P.S. (2013), "Seismic Analysis of RCC building with and without Shear wall", International Journal of Modern Engineering Research, Vol. (3), Issue (3), pp.1805-1810, May- June.
7. Esmaili, O., Epackachi, S., Samadzad, M. and Mirghaderi, S.R. (2008), "Study of structural RC shear wall system in a 56-story RC tall building", Proceedings of the 14<sup>th</sup> world conference on earthquake engineering, Beijing, China, October 12-17.
8. Misam, A. and Magulkar, Madhuri N. (2012), "Structural response of soft story high rise buildings under different shear wall location", International journal of civil engineering and technology, Vol. (3), Issue (2), pp.169-180.
9. Venkata, S.K.N, Krishna, Sai M.L.N., Satynarayana, S. V. (2013), "Influence of reinforced concrete shear wall on multi-storeyed buildings", International Journal of Engineering Sciences & Research Technology, Vol. (2), Issue (8), pp.2055-2060.
10. Venkatesh, S.V. and Bai, H. Sharada. "Effect of internal & External shear wall on performance of buildings frame subjected to lateral load", International Journal of Earth Science and Engineering, Vol. (4), No. (6), pp.571-576.
11. Dasgupta, K. (2007), "Seismic Design of slender reinforced concrete structural walls", Proceedings of first IITK REACH symposium at Parwanoo, March 2007, IIT Kanpur, Vol. 8, No. 2, December.
12. Medhekar, M.S. and Jain, S.K. (1993), "Seismic behaviour design and detailing of RC shear wall", Part II: Design and detailing", The Indian Concrete Journal, Sept.
13. Yoshimura, K. and Kikuchi, K. (1984), "On practical method for evaluating lateral stiffness of R/C shear walls arranged irregularly into ductile moment resisting frames", Proceedings of the 8<sup>th</sup> world conference on earthquake engineering, San Francisco, California.
14. Greeshma S. and Jaya K.P. (2008), "Seismic behaviour of shear wall-Slab connection", Proceedings of the 14<sup>th</sup> world conference on earthquake engineering, Beijing, China, October 12-17.
15. Madan, S.K., Malik, R.S. and Sehgal, V.K. (2015), "Seismic evaluation with shear walls and braces for buildings", World academy of Science, Engineering and Technology, International Journal of Civil, structural, construction and Architectural Engineering, Vol. (9), No. (2).

## **“Design and Implementation of Low Power Consumption and Wide Bandwidth Tia”**

**Navita boora \***

**ms Himanshi sainsi \*\***

*A new topology for designing lowvoltage two stage amplifiers is presented. By employing 2<sup>nd</sup> generation positive current conveyor followed by a operational amplifier in an thessaurus manner, design circumvents the problem of trying to achieve large trans impedance in a lowvoltage area. It is shown that this configuration also results in near gain independent closedloop bandwidth defined by a single feedback resistor. The proposed amplifier were verified experimentally by a chip designed using Taiwan Semiconductor Manufacturing Company's 0.16micrometer digital CMOS process of a single-ended power supply of 1.8 V*

***Index Terms—Current feedback amplifier (CFA), low-voltage operational amplifier.***

### **I.Introduction**

Trans-impedance amplifier (TIAs) are integral components of complementary metal-oxide semiconductor (CMOS) integrated low-current measurement systems. Resistor and capacitorbased TIAs for processing level current and low voltage has found numerous applications in CMOS electrochemical biosensors including patchclamp electrophysiology chips [1] [2], integrated nano pore and ion channel sensors [3][4][5] and onchip electrochemical DNA sensor arrays [6][7]. Patch clamp electrophysiology is a technique used to measure the current that flows through a cell membrane which has applications in drug discovery and research for pharmaceutical development [2]. Ion channels along the cell membrane control the flow of ions in and out of the cell which gives rise to a current. Ion channels are categorized by the way in which they are gated, that is, ion channels are open or closed by different mechanisms.

---

\* Research scholar, Eced, Dcust, Murthal

\*\* Assistant professor, Eced, Dcru, Murthal

## **II. Related Work**

The topology used in Reference [1] is Differential Regulated cascode topology which works on the process technology of 0.16 $\mu$ m CMOS technology. It was mainly designed for optical interconnects. But differential regulated cascode topology results in more noise, hence [2] comes up with another topology named as 1 stage push-pull inverter based Trans impedance amplifier. It was mainly for an integrated CMOS optical receiver with clock and data recovery circuit. It works on the process technology of 0.35 $\mu$ m CMOS technology. Here the noise produced is less as compared to [1]. [3] Uses a regulated cascode input stage with shunt feedback topology. Here the supply voltage is 3V. This paper presents look of AN optical receiver analog front-end circuit capable of in operation a pair of 5 GHz. fictitious in a too low value zero.35 $\mu$ m digital CMOS method, this computer circuit integrates each transresistance electronic equipment and post limiting N electronic component on one chip. Shunt-shunt feedback topology with cascade stage is planned. The cascade topology is employed to cut back the input capacitance of the electronic equipment and increase the information measure. . The amplifier has been designed to be pseudo differential so as to enhance the common mode rejection. The optical forepart bestowed in 5 can have application in Optical Scanning Acoustic magnifier System (O-SAM), during this work, AN ultra-fast optical front-end mistreatment improved regulated cascade theme is developed supported AMS zero.35mm CMOS technology. The receiver consists of an united photodiode, a trans resistance electronic equipment, a mixer, amplifier device and other device like output buffer. 5 stage push-pull electrical converter based mostly topology is planned [6] and a trans resistance circuit. A series inductive peaking is employed to the attractive information measure. The planned structure operates at an information rate of ten Gb/s with a BER of 10-20 and was enforced in a very zero.35  $\mu$ m CMOS method. CMOS Regulated cascode with electrical converter based mostly Cherry Hooper electronic equipment was designed in [7]. It was a 1.57mwatt CMOS Trans resistance electronic equipment for VHF Micromechanical Reference Oscillators. In [8] 2 stage push-pull inverters based mostly topology is introduced that was optimized for police investigation terribly weak signal generated for research imaging within the scanning microscope (SEM)



### III.Circuit Design

The two stage push-pull inverters based Trans impedance amplifier shown in fig.2. It consists of two inverters connected with each other serially. Also after every inverter a NMOS with diode connected load is placed which is used to high bandwidth and decrease miller effect. In proposed TIA circuit, a feedback resistor was also used which is replaced with NMOS transistor as an main feedback resistor biased to the gate voltage Vbias. Besides good controll, the implementation of the feedback resistor using a NMOS saves chip area immensely. The value of Feedback resistor can be determined by using equation 1, which is as follows-

$$R_f = \frac{L}{W\mu C_{ox}(V_{gs}-V_t)}$$

Where  $W$  =width,  $L$  = length,  $V_{gs}$  = gate to source voltage,  $V_t$  = threshold voltage and  $\mu C_{ox}$  = Trans conductance parameter.

There is a voltage source Vdd of 1.6 V which is applied to each PMOS transistor.

Amplification of signal from input to output. In TIA output is taken at terminal Vout, and a portion of output is given as feedback to the input of the amplifier.

Fig.2. Circuit diagram Of Proposed Trans impedance amplifier.

$$A = \frac{V_{out}}{I_{in}}$$

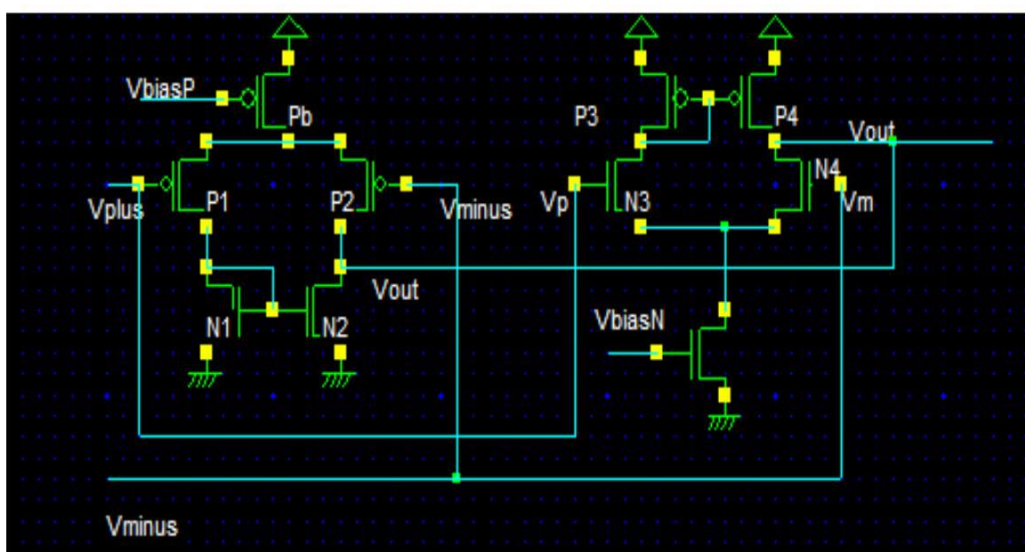



Three stages Trans impedance amplifier consists of three identical cascaded stages having seven NMOS transistor and three PMOS transistor. A photocurrent of  $3\mu\text{A}$  is used in the circuit. A dc voltage of 1.3 V is applied to the feedback transistor as a biasing voltage. The transistors should be in saturation region in order to make them work as amplifier, except the feedback transistor which works in linear region because it is to be used as a resistor.

The simulation is carried out using Spectre simulator of DSCH. The simulator works on  $0.18\mu\text{m}$  CMOS technology. Gain Calculation of TIA: As explained earlier, the gain of a Trans impedance amplifier is given by the ratio of the output voltage to input current. The gain of single stage TIA is given by,

$$A = \frac{gm13 + gm20}{gm15}$$

a gain by the three stage TIA, the cube of single stage TIA is done. This is because the stages of TIA are connected in series; hence the gains of all the stages are multiplied. Since the aspect ratios of all the stages are same, hence the gain of all the stages will remain same and the overall gain will be cube of single stage TIA. The gain thus calculated is 54.55 dB. Fig 3 shows the gain of proposed TIA.

Bandwidth calculation of TIA: The 3 dB bandwidth of the TIA is calculated at the point where the gain drops by 3dB. The bandwidth enhancement is one of the most important factor in designing a TIA. The bandwidth enhancement is done by proper selecting the value of the diode connected MOS. mathematically the bandwidth can be calculated by a formula-

$$\text{Bandwidth} = \frac{1+A}{2\pi R_f C}$$

Where A is the gain,  $R_f$  is feedback resistances and C is the capacitance. The bandwidth thus calculated is obtained as 371.32MHz. Fig 4 shows the bandwidth of proposed TIA.

Noise and Power calculation of TIA: The noise calculated here is the input mentioned sound. The input mentioned noise is defined noise calculated by keeping all the input

sources calculate calculated by removing the sources (By open circuiting current source and short circuiting the voltage sources), this noise thus calculated will not show the effect of the input sources on the device, Hence In this noise calculation the current source is placed in the circuit and then the noise is calculated. The noise thus calculated is obtained as  $0.827 \times 10^{-12} \text{A}/\sqrt{\text{Hz}}$ . Fig 5 shows the noise of proposed TIA. The power dissipation of the device should be as low as possible. Here the DC Power dissipated is 0.871mW. Layout of Proposed TIA: After the analysis and calculations are done, layout to the planned TIA is made by layout tool “Asshura” of cadence. The connections are done in such a manner so that there should not be any Design rule Check (DRC) error. Figure 6 show layout of proposed TIA.

#### IV.Result and Simulation

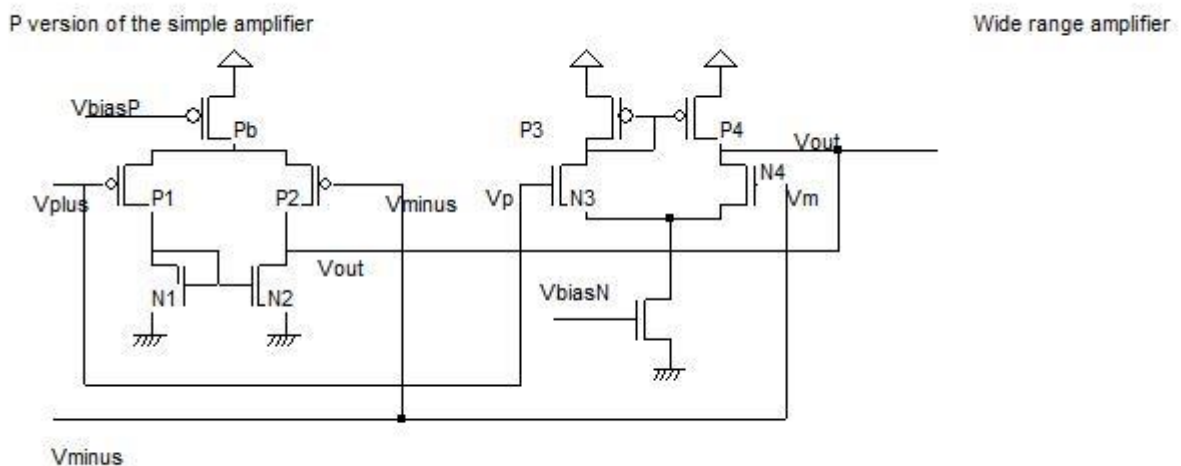

Fig.3. Circuit diagram Of Proposed Trans impedance amplifier.

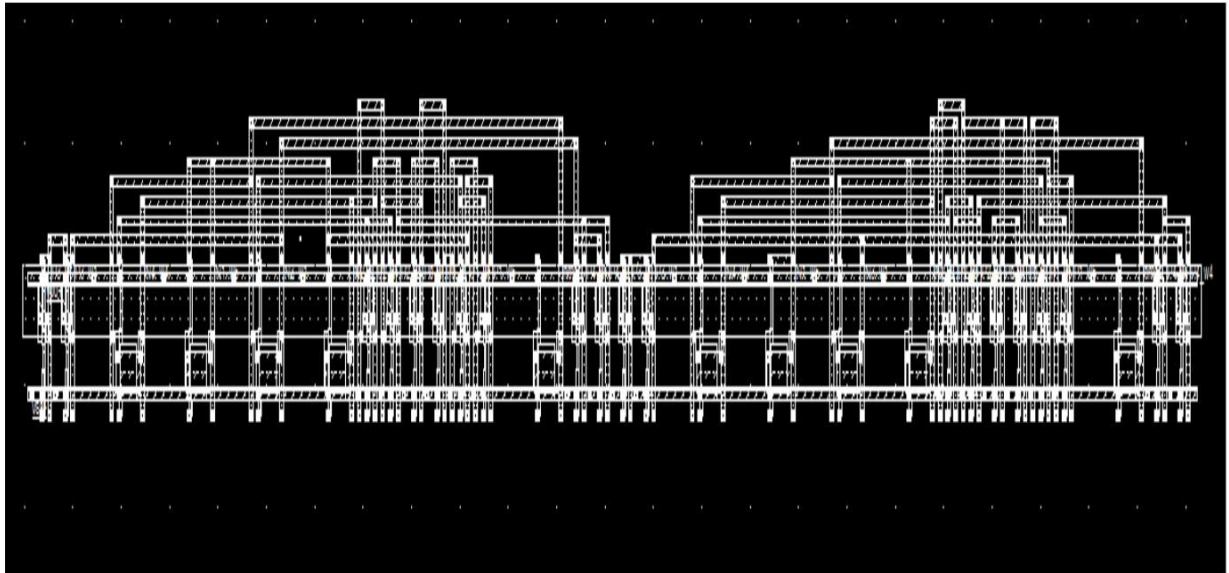
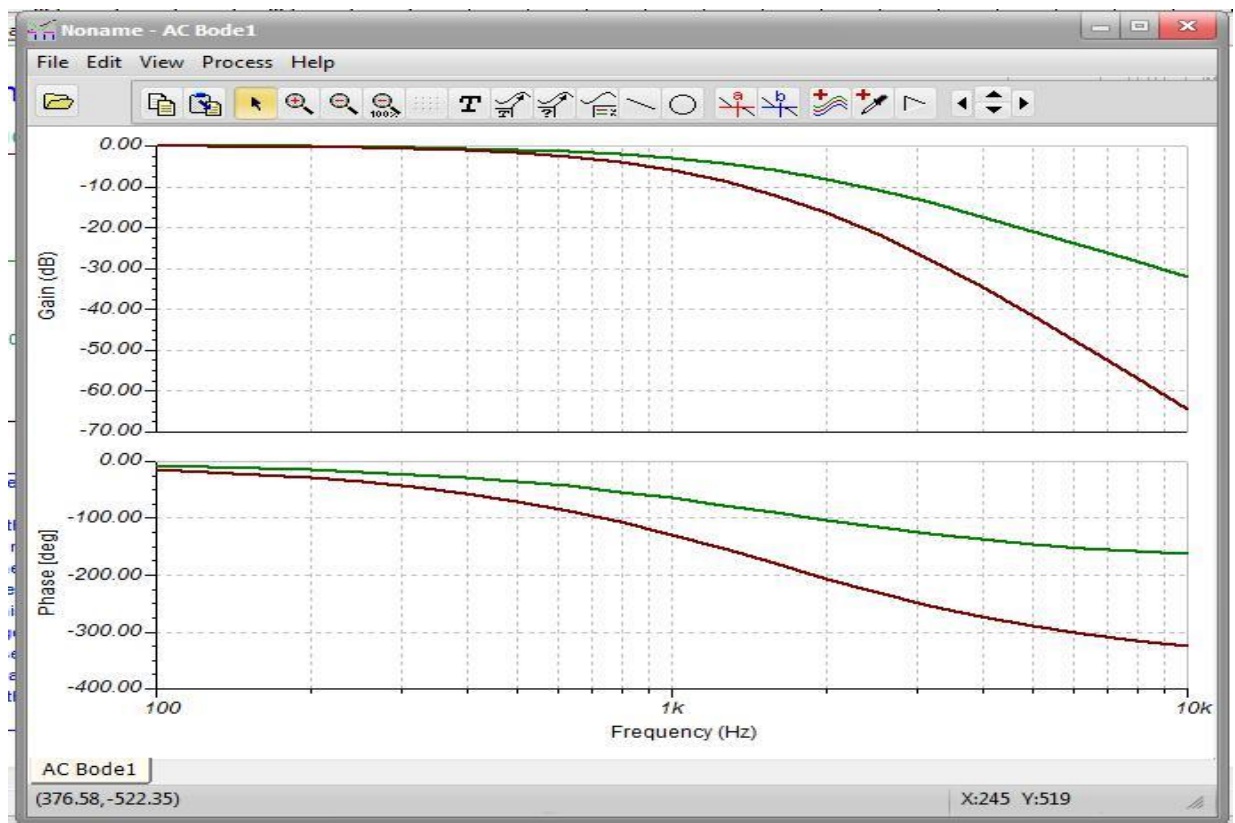

Fig. 4. Layout of Proposed TIA



Design of TIA	[1]	[2]	[3]	[4]	[5]	[6]	[7]	[8]	This work
Process	0.25µm Si	0.35µm Si	0.35µm Si	0.18µm Si	0.35µm Si	0.35µm	0.18µm Si	0.35µm	0.16µm
Technology	CMOS	CMOS	CMOS	CMOS	CMOS	Si CMOS	CMOS	Si CMOS	Si CMOS
Topology	Differential Regulated Cascode	1-stage push pull inverter	Regulated cascade input with shunt feedback	Shunt-shunt feedback with cascode gain stage	Improved regulated cascode	5-stage push pull inverters	Regulated cascode with Cherry- Hooper Amplifier	3-stage push pull inverters	2-stage push pull inverters
Supply voltage(volt)	2.5	3.3	3	3.5	3.3	3.3	1.5	3.3	1.2
Bandwidth	670MHz	910.5MHz	2.2GHz	1.8GHz	6GHz	10Gb/s	280MHz	12.5MHz	401.00MHz
Input referred noise(pA/√Hz)	20.9	6.03	17.1	9	21	25.8	-	3.54	0.827
Power consumption	27mW	-	-	115mW	-	87.4mW	1.57mW	60mW	0.871mW
Gain(dB)	80	69.7	55	64	51	36.56	99	107.3	54.55

**TABLE I: PERFORMANCE COMPARISON OF THIS WORK WITH RECENTLY PUBLISHED TIA'S**

### V. Conclusion

A trans impedance amplifier is designed using 0.18µm CMOS technology. To main trans impedance amplifier (TIA), feedback resistor R<sub>f</sub> of conventional trans impedance amplifier which was implemented using PMOS transistor has been change to NMOS transistor as an better feedback resistor. These circuits follow at 1.6V power supply voltage for a current of

3 $\mu$ A. The proposed trans impedance amplifier possesses low noise, low power dissipation, high gain and high bandwidth. The simulation results show that the proposed Trans impedance Amplifier exhibits a power dissipation of 0.871 mW, trans impedance gain of 54.55 dB, bandwidth of 371.32 MHz, an input referred noise of  $0.827 \times 10^{-12} \text{A}/\sqrt{\text{Hz}}$ . Table I shows the comparison of various topologies of TIA's with this work. The future work in this amplifier can be done in terms of increasing the number of stages and to decrease the sizing of the transistors. Here the minimum length is taken as 180nm. With the advancement of Technology, the length and width of the device will decrease and thus the power dissipation will also decrease.

### References

- [1] S. S. Mohan, M. del Mar Hershenson, S. P. Boyd, and T. H. Lee, "Bandwidth extension in CMOS with optimized on-chip inductors," *IEEE J. Solid-State Circuits*, vol. 35, no. 3, pp. 346–
- [2] E. Säckinger, *Broadband Circuits for Optical Fiber Communications*. Hoboken, NJ: Wiley, 2005.
- [3] D. Johns and K. Martin, *Analog Integrated Circuit Design*. New York: Wiley, 1997.
- [4] K. Schrödinger, J. Stimma, and M. Mauthe, "A fully integrated CMOS receiver front-end for optic gigabit Ethernet," *IEEE J. Solid-State Circuits*, vol. 37, no. 7, pp. 874–880, Jul. 2002.
- [5] B. L. Kasper, A. R. McCormick, C. A. Burrus, Jr., and J. R. Talman, "An optical-feedback trans impedance receiver for high sensitivity and wide dynamic range at low bit rates," *J. Lightw. Technol.*, vol. LT-6, no. 2, pp. 329–338, Feb. 1988.
- [6] D. M. Pietruszynski, J. M. Steininger, and E. J. Swanson, "A 50-Mbit/s CMOS monolithic optical receiver," *IEEE J. Solid-State Circuits*, vol. SC-23, no. 6, pp. 1426–1433, Dec. 1988.
- [7] B. Wilson and J. D. Drew, "High-performance trans impedance formulation for MESFET- and HBT-based monolithic microwave integrated circuits," *IEE Proc. Circuits, Devices Syst.*, vol. 145, no. 6, pp. 429–436, Dec. 1998.
- [8] A. S. Sedra and G. W. Roberts, "Current conveyor theory and practice," in *Analogue IC Design: The Current-Mode Approach*, C. Toumazou, F. J. Lidgley, and D. G. Haigh, Eds. London, U.K.: Institution of Engineering and Technology (IET), 1990, pp. 93–126.

## **Effect of Government Expenditure on the Economic Growth of India**

**Dr. Sandeep Kumar\***

**Shruti Sharma\*\***

### **Abstract**

India, being a planned economy has always found Public Expenditure as a significant part of the growth of the economy as a whole, be it public sector or private sector. Being a developing nation with a high population, reducing poverty and generating employment have always been big issues. However, the governmental spending has helped these sectors to grow and contribute significantly towards the overall economic growth. This paper concentrates upon the five major sectors which have shown significant growth in the time span ranging between 1980-81 to 2014-15, thereby establishing a strong relationship between economic growth and Public Expenditure.

**Key Words-** Public Expenditure, Economic Growth, Sector

### **Introduction**

The concept of developing democracy introduced laissez faire type of economy. It simply meant that everything will take its own course with no Governmental intervention. In other words, the economists like Adam Smith (Wealth of Nations, 1776) started believing in the self-correcting quality of the market and "invisible hand"; which got a major blow in early 20<sup>th</sup> century with the onset of "The Great Depression" (1929). Rampant unemployment and lockout of industrial units led to a huge fall in the economic activities all around the world. The worst hit, were the capitalist economies which had blind faith in self correcting virtues of the markets wherein they believed that there are ups and downs in the economies and they are always corrected all by themselves, and no intervention of the Government is ever required for the running of the economy of the country. All of a sudden, the debates started about the relevance of the lone concepts of capitalism or socialism in the growth of any economy. The Economists went on to defend their respective beliefs. There was hue and cry in the economic as well as the political world.

To solve this, J.M Keynes in his book, The General Theory of Employment, Interest and Money (1936), suggested strong governmental intervention in the economy. This theory did wonders and the world was saved. Keynes also questioned the prevalent version of capitalist economies, wherein, the basic things were market determined which led to the pauperization of the poor. This led to increase in the importance of public expenditure in order to supply public goods to the common man. This may be regarded as the point of time in which the concept of 'Welfare State' may find its roots. It is also noteworthy here, that these theories were given by the economists of developed economies where the problems were of different nature than, the developing nations. The basic infrastructure and industry was very developed in these nations. People had food, clothing and shelter. There was enough money for investment in research and innovation. On the other hand, the developing economics were still struggling for basic amenities of food, clothing and

---

\* Principal, Guru Teg Bahadur College, Bhawanigarh

\*\* Research Scholar, Punjab Technical University



shelter. In a way, the Welfare State proved to be a boon for everyone specially the developing nations.

With the advent of new independent nations, the new leaderships also emerged. However, these leaders had the option of going either way; either capitalism or socialism. India was one such nation and our Leadership accepted the mid way i.e socialist-capitalist economy, wherein, the private sector was present with the presence of welfare state, as it was thought that initial help from both type of economies like USA and USSR will lead to wonders for the new and staggering economy. But, this remained a distant dream. Besides being a dumping ground of both the countries. There was no sign of development in the new economies. Almost at that time, Soviet Union introduced the concept of Planning, which was immediately accepted by India as well. Till 2012, India has remained a planned economy working on the lines of Five Year Plans and some Annual Plans. Besides some hiccups like the one in early 1990s, the economy developed with steady rate. It is noteworthy that the economies today, including India, incur expenditure to fulfill the following requirements of the Economy-

1. To correct distortions due to failure of the markets.
2. To regulate the activities of the private sector so that they don't leave economy in bad state.
3. To provide economic and social infrastructure
4. To enhance the production activity of the economy.

Public Expenditure has played an important role in the development of both developed as well as developing countries. In developed economies, public expenditure is meant for prevention of cyclical fluctuations and improvement in the income distribution. In developing economies public expenditure has played a threefold role of promoting economic development, redistribution of income and balanced regional development.

Today, Public Expenditure, especially expenditure on infrastructure has become a measuring rod for the development of the economy. Several factors have influenced public expenditure on infrastructure, namely, rate of urbanization, openness, government revenue, external reserves, population density, type of government *ab initio*. Several studies have analyzed the impact of public spending on economic growth in the short and long-run in the developing countries including India. Public expenditure, which refers to the expenses Government incurs for its own maintenance, society and the overall economy, is found to be continuously increasing overtime. This is because these fiscal operations are recognized as major tools for the management of the economy and stimulation of economic growth and development (NISER, 2004; Agenor and Dason, 2006).

Besides, government spending is varied ranging from education, defense, general administration, health, to water supply, electricity generation and supply, roads, telecommunications among others.

Till recently, due to presence of rampant corruption, red tapism etc the private investment in infrastructure development had decreased tremendously. But, with the change in the policy of the Government and reducing the bureaucratic entanglements has led to much improvement in the investments, both from foreign and domestic. The schemes like Pradhan Mantri Gram Sadak Yojana, Kaushal Vikas Yojana, National Rurban Mission etc. has led to the development of a platform wherein the economy is developing both, economically, socially and demographically too.

The same Public Expenditure is playing a significant role in the development of Indian Economy. Before moving on to the features of Public Expenditure, the following features of Indian economy can be considered as important.

### **Review of Literature**

Shatti (2014) studied the impact of public expenditure on economic growth in Jordan. This research aimed to examine the impact of the public expenditures on economic growth in Jordan during the time period (1993–2013), by determining the contribution of the current and capital expenditures on Education, Health, Economic Affairs, and Housing and community Utilities as a percent of the total public expenditures, and then examining the impact of each one of them on economic growth in Jordan. The empirical results showed that the impact of current and capital expenditures on education had failed to enhance economic growth, and that was due to the high cost of education, especially higher education in the private sector in Jordan, as well as the growing rate of unemployment, and expenditures on health and economic affairs should be encouraged due to their positive impact on economic growth.

Arewa and Nwakahma (2013) conducted a long term analysis on macro economic variables and the dynamic effect of Public Expenditure in Nigeria. The authors considered GDP, consumer price index and unemployment as a set of macroeconomic variables. The required data was collected from CBN statistical bulletin for a period of 1989 to 2011. It was discovered that there was a long run relationship between government expenditure and the specified macroeconomic variables. The study also concluded that an increase in capital expenditure improves economic bliss, while recurrent expenditure proved detrimental for the growth.

Srinivasan (2013) researched on the causality between Public Expenditure and Economic Growth in India. This study investigated the causal nexus between public expenditure and economic growth in India using co integration approach and error correction model. The analysis was carried out over the period 1973 to 2012. The Co integration test result confirmed the existence of long-run equilibrium relationship between public expenditure and economic growth in India. The empirical results based on the error-correction model estimate indicated one-way causality runs from economic growth to public expenditure in the short-run and long-run, supporting the Wagner's law of public expenditure.

Dolli (2012) studied the trends and growth of Public Expenditure in India in the time period between 2001-2012. The results concluded that in today's scenario Wagner's Law was most applicable which said that the role of public sector rises with the growth of the economy. During the time period, the plan expenditure increased more than the non-plan expenditure. It was also suggested by the author that percentage public expenditure should be more towards the capital expenditure than the revenue expenditure, and in order to reduce the interest payments, the government should raise fewer loans.

Saiyed (2012) conducted a study to understand the bi-directional relationship between economic growth and growth of public expenditure in India. The time period of this study was 1992-2012. The results suggested that there was a significant bi-directional relationship between year-wise number of national income and the public expenditure of the country. However, the author could have also considered a pre-economic reforms era as well, so that the clear scenario of the aforesaid relationship could be well established.

### **Need for Study**

The review of literature clearly shows that the studies done beforehand have mainly constricted their time period under consideration to post liberalization era. There has been almost none comparison between both the time periods i.e pre and post liberalization era. This study will take up the time period from 1980-81 till 2014-15, which will paint a very clear picture of the whole scenario of economic growth due to the public expenditure in India.

### **Objective of the study**

To study the effect of the growth of Public Expenditure on Economic Growth of India

### **Research Methodology**

To study the impact of Public Expenditure on Economic Development, correlation between Public Expenditure as well as different sectors like Primary, Secondary, Tertiary etc were carried out by collecting a time series data from various secondary data resources like the Economic Survey of India (since 1980-81), Publications of Ministry of Finance, Reserve Bank of India Bulletins, Union Budgets (since 1980-81), and various Five Year Plans etc. the time period of the data collection ranged from 1980-81 to 2014-15.

### **Results and Analysis**

India, being a democratic country of socialistic nature, Public Expenditure has always been a very important part of the overall growth of the economy. However, with the time, the pace and sectoral differentiation has changed. It is also very clearly visible in the table underneath which shows the effect of Public Expenditure on the economic growth of India, which has been distributed in various sectors.

The first sector under consideration is primary sector which includes Agriculture, Forestry, Fishing, Mining and Quarrying. This sector is the most important sector of the Indian Economy. Since Independence, this sector has generated maximum employment. With time its contribution into GDP has been reducing since Government has diversified its interest and funds to other sectors as well, still its GDP contribution is approximately 18% (2015-16) and it gives employment to at least 50% of the workforce of the country (2015-16). Recently, the trend of agribusiness has taken over this sector with many farmers moving towards cultivation of cash crops and exporting them. Even, fisheries are concentrating more on export. This has helped this sector to earn Foreign Exchange. This sector has always seen growth, ranging from 58745 Crores in 1980-81 to 2248888 Crores in 2014-15. The correlation comes out to be highly significant at 0.99, with the Total Public Expenditure. The Government has helped this sector grow by introducing Green Revolution wherein hybrid varieties of wheat were introduced that almost doubled the production and made India self sufficient in food grains production. The National Food Security Mission introduced from the Rabi season of the year 2007-08 saw the increase in Public Expenditure in this sector. The fundamental objective of this scheme was to increase the production of Wheat, Rice, Coarse Cereals and Pulses, by sufficiently supporting and efficiently upgrading the cultivation techniques with respect to the locale cultivation skills. Restoration of soil ripeness and improving the farm level economy to restore and boost up the confidence of the farmers. This mission was kept as the centre point of 12<sup>th</sup> Five Year Plan and proved to be successful as well.

The second sector under consideration is the secondary sector including Manufacturing, Construction, Electricity, Gas and Water Supply. This sector contributes almost 24% to the GDP of the country. India's industrial sector gives employment to 17% of the total

workforce. Although, Agriculture is the primary sector but the Government of India has always emphasized upon the development of this sector. Thus, various policies and strategies have been framed from time to time for its development. In the first two time periods under consideration, that is 1980-81 and 1985-86, the public expenditure in this sector showed growth worth 36090 crores and 60593 crores respectively. However, the third period of 1990-91, which saw the adoption of LPG policy by the Government, the total worth of this sector shot up to 1127079 Crores, which was the highest ever, reason being the entry of Private Sector to various industries without any restrictions, which led to stupendous growth. But, this growth again saw a downfall, and seven digit growth fell back to six digits i.e 280791 Crores in 1995-96, 474323 Crores in 2000-01 and 859410 Crores in 2005-06 and again went to seven digits in 2010-11 and 2014-15, being, 1763584 crores and 2898782 crores. The mean of this sector has come to be 670824.57 and the correlation coefficient is highly significant at 0.98.

Today, India is a big player in the world market in various industrial sectors such as, Steel, Electronics, Petrochemicals, Textiles, Engineering and Machine Tools and most recently, the Software. With the Governmental efforts of increasing infrastructural growth in terms of both tangible and intangible, this sector has seen huge FDI investments.

The Government of India has also taken initiatives in terms of Small Industries Development Organization (SIDO), National Small Industries Corporation Limited (NSICL), Small Industries Development Bank of India (SIDBI) and various other banks and financial institutions which provide finance for the running of this sector.

Most recently, the schemes like Stand-Up India and Make in India have been launched by the Government. Under the first scheme, the main focus is on the handholding support to be given to ST/SC category people and women for their mainstreaming. However, in the later scheme, the main objective is to attract the foreign as well as Indian companies to manufacture their products in India. This initiative also focuses on minimizing the environmental impact, maintaining high quality standards and enhancing skills of the workforce in 25 selected sectors.

So, the overall picture of this sector looks quite bright as the government has always given it a priority.

The third sector under consideration is the tertiary or the service sector that includes trade, hotels, transport and communication. Since Independence the service sector was not considered much important and majority of public expenditure was done to boost up the Primary as well as Secondary sector. However, the viewpoint of Government changed during the early 1980s, when it was realized that service sector forms an important part of the modern economies consisting of both industrial and post industrial parts. It is also clear from the table underneath that public expenditure has seen a consistent growth in the tertiary sector. It was Rs. 26946 Crores in 1980-81, 48022 in 1985-86, 100318 in 1990-91, 231175 in 1995-96, 443169 in 2000-01, 846606 in 2005-06, 1779630 in 2010-11 and finally, 1945319 in 2014-15. The mean for all these years comes out to be 806413 and correlation with Public Expenditure is 0.94 which is highly significant. The realization that the world is now Knowledge led; that is driven by Information Technology, led to increase in investment and building up of the support infrastructure. The Government also controlled and supported the telecommunication services, which are integral to Global Integration, by formulating Telecom Policy (1999) and Broad Band Policy (2004) etc. Besides all this, a number of promotional and beneficial measures have been taken to



promote trade, Hotels, ITeS and real estate sector as well. Thereby, helping the country reach the point in the services sector where it is right now.

The fourth area under consideration includes Finance, Insurance and Real Estate. These sectors have developed quite recently. In Financial organized sector, there were only a few banks like Punjab National Bank, Bank of India, and State Bank of India etc. for quite a long period. Other financial institutions included the unorganized sector in the form of aartiyaas or local money lenders. However, slowly and slowly, the financial sector diversified in the form of private banks, Non-banking financial institutions, agricultural banks, cooperative banks, Mutual Funds etc. Recently, the Government of India has taken many efforts to induce growth in this sector. In order to create tax compliant society and transparent tax administration, the Finance Ministry has launched Operation Clean Money Portal. The Security Exchange Board of India (SEBI) has given permission to the local security exchanges to launch contracts in the commodity market. This would provide a new cost effective hedging tool to the farmers and other market participants. The Insurance sector has seen many phases of growth before achieving the current scenario. It started as Oriental Insurance Company in 1818 and became Life Insurance Corporation of India in 1956. Another Insurance company started up in 1972 as General Insurance Corporation of India and its four subsidiaries. Finally, with Banking Sector Reforms and LPG Policy, it became liberalized thereby, opening avenues for private insurance companies. Today, this sector has 54 Insurance companies out of which 24 are life insurance companies and 33 as non-life insurers. The Government of India has started Pradhan Mantri Vaya Vandana Yojna which is a pension scheme for providing guaranteed 8 percent returns to all senior citizens for the policy tenure of 10 years. The Real Estate Sector, especially in urban areas has developed quite recently. However, it is estimated that it will reach to the market value of 180 Billion USD by 2020. And the market size of this sector will grow at Compound Annual Growth Rate of 11.2 percent by the year 2020. In this sector, Retail, Hospitality and commercial sectors are also growing rapidly, thereby providing the much needed infrastructure to the India's growing needs. Smart City Projects, AMRUT (Atal Mission for Rejuvenation and Urban Transformation) Projects are also paving way for development of cities and finally, to the growth of Real Estate. The Securities and Exchange Board of India (SEBI) has given its approval for the Real Estate Investment Trust (REIT) platform which will help in allowing all kinds of investors to invest in the Indian real estate market. It would create an opportunity worth Rs 1.25 trillion (US\$ 19.65 billion) in the Indian market over the years. The table underneath also explains the growth of these sectors very clearly. Starting from the net worth of Rs. 17835 Crores in 1980-81; it reached to 2038838 Crores in 2014-15, which is a significant growth to show. The correlation of the growth figures in various years with the Public Expenditure comes out to be 0.95, which is highly significant. So, it can be rightly said that today India is a brightly shining economy, globally, because of the robust, Financial, Insurance and Real Estate sector.

The fifth sector that has seen the growth due to public expenditure is Community, Social and Personal Services, in short the social services sector. This sector has seen growth due to Structural Adjustment Programs that were introduced in early 1980s in order to do mainstreaming of the downtrodden. The table shows that there has been constant rise in this sector in absolute terms i.e starting from only Rs. 19927 Crores in 1980-81, Rs. 34284 Crores in 1985-86 to 1015850 Crores in 2010-11 and finally, to 1355247 Crores in 2014-15. This sector is also showing a highly significant correlation with Public Expenditure.

But it should also be noted that this sector is highly venerable in terms of percentage share in Public Expenditure especially during the times of financial constraints. Expenditure in social sector means spending on education, health, family welfare, housing schemes, labor and employment programs etc. through the table, it social services sector is compared with the other prior sectors (Primary, Secondary and Tertiary) then its share in GDP has always been very less all through the concerned time period. Even as many reasons can be sighted for this slow growth, the major is that most of the social sector schemes and subsidies focus on agriculture sector only, in the form of fertilizer subsidy, food security through Public distribution system. Today, this sector comprises of merely 2 percent of the GDP, which can be enhanced wisely. It is noteworthy that Human Capital is an asset for any developing nation and if this sector is given proper importance, it will create a skilled human capital that will help in the overall growth of the economy. The backwardness of agriculture and industry is due to lack of skilled labor which leads to lesser profits. So, a strong human resource will result in a developed nation in the long run. Some of the social sector schemes running successfully today are Atal Pension Yojana, Deen Dayal Upadhaya Grameen Kaushalaya Yojna, The Indira Gandhi Matritva Sahyog Yojna, MGNREGA, Pradhan Mantri Aadarsh Gram Yojna, Pradhan Mantri Jan Dhan Yojna, Sabla, National Rural Livelihood Mission, Jawahar Lal Nehru Urban Renewable Mission, Sukanaya Samridhi Yojna, Smart City Mission, Pradhan Mantri Aawas Yojna, Pradhan Mantri Ujjawala Yojna, Stand Up India and many more.

**Table 1: The Growth of various Sectors with the growth of Public Expenditure**

Year	Agriculture, Forestry, Fishing, Mining and Quarrying	Manufacturing, Construction, Electricity, Gas and Water Supply	Trade, Hotels, Transport and Communication	Financing, Insurance, Real Estate and Business Services	Community, Social and Personal Services	Total Public Expenditure
<b>1980-81</b>	58745	36090	26946	17835	19927	149987
<b>1985-86</b>	88083	60593	48022	30819	34284	288095
<b>1990-91</b>	168166	1127079	100318	64598	70019	578667
<b>1995-96</b>	319243	280971	231175	143791	140190	1213241
<b>2000-01</b>	506476	474323	443169	282316	294459	2154680
<b>2005-06</b>	732234	859410	846606	493102	459151	3667253
<b>2010-11</b>	1524552	1763584	1779630	1165243	1015850	7702308
<b>2014-15</b>	2248888	2898782	1945319	2038838	1355247	12340772
<b>Mean</b>	2927261.7	670824.57	806413.26	643262.8	499677.31	9318.63
<b>r</b>	0.99	0.98	0.94	0.95	0.99	0.92
<b>significance</b>	HS	HS	HS	HS	HS	HS

**Conclusion**

It is very much clear from the above explanation and the tabular data that Public Expenditure in the right direction has led to significant growth of the economy as a whole



and various sectors, individually. With the growth of these sectors the avenues of more employment have been generated which has in turn raised the standard of living of the majority of population. It is a positive sign that we are on a right path becoming a developed economy in the near future.

**Bibliography**

Arewa, A., Nwakahma, P.C. (2013, December). *Macroeconomic Variables and the Dynamic Effect of Public Expenditure: Long-term Trend Analysis in Nigeria*. Journal of Knowledge Management, Economics and Information Technology. Volume III. Issue-6. pp. 1-32.

Dolli, M. (2012, April). Trends and Growth of Public Expenditure in India During 2001-2012. International Journal of Research in Commerce, Economics and Management. Volume 2. Issue 4. pp.51-56.

Saiyed, S.A. (2012). *Bi-Directional Causal Relationship Between Economic Growth and Growth of Public Expenditure in India*. International Global Research Analysis. Volume 1. Issue 7. pp. 28-30

Shatti, A.S.A. (2014). *The Impact of Public Expenditure on Economic Growth in Jordan*. International Journal of Economics and Finance. Volume 6. Number 10. pp. 157-167.

Srinivasan, P. (2013). *Causality Between Public Expenditure and Economic Growth*. International Journal of Economics and Management. Volume 7. Number 2. pp. 335-347.

## **Sports Promotion in Delhi: An Analysis**

**Devsri Laikangbam\***

**Kalpana Sharma\*\***

### ***Abstract***

*This paper attempted to provide an analysis of sports promotion and development in the past few years in the capital of India. The analysis is based on the aspects of promotion and development of sports only. It has been found that the sport development has seen various aspects further which provide developmental activity through sport. Further, the sports promotion also has been analysed with the help of various stake holder and available review of literature and it has been found that sports has been promoted through leagues, events and sporting activities which have an upward trend as reported with the higher fan following in the literature*

***Key:*** Sports Volunteers, Sport Career, Sports Agents, Stake holder, Sport Fan, Sport Retail, Sport Tourism, Sports, Sports Promotion, Sport Education, Fitness & GYM.

### **Introduction**

Sports and games form a very essential part of human resource development. Government of India has given importance to sports for development and excellence too. It has been the attempt of the Government to set down procedures for effective coordination among various agencies which involved in sport promotion. Government also provides training and other facilities to sportspersons for achieving excellence in the national and international events. Sport development is a national priority, as it advances dynamic way of life, youngster and youth development, social comprehensiveness, employment opportunities, peace and development, or more each of a feeling of belongingness and national pride. (Government of India, 2011). Government of India also has been, from time to time, taking various steps and initiatives to promote good governance practices in the management of sports at the national level in pursuance of successive National Sports Policies. These policies are based on the 2 Basic Universal Principles of Good Governance of Olympic and Sports movement and do not, in any manner, contradict or interfere with the autonomy of the national sports bodies in discharging their functions and duties in accordance with the International Olympic Committee Charter.

Physical activities were always a part of human leisure activity. (Kosava). Some physical education teachers are amazed at the energy they must spend motivating students to dress and participate in physical activity at the lowest intensity levels (Ennis, 1995). Sport Education makes direct comparisons between the organization and participation of sports within society and the teaching of Physical Education within the National Curriculum. Some suggest that Sport Education provides a particular focus on participation in a wide range of sporting activities rather than skill acquisition, therefore providing opportunities for pupils of all abilities to achieve in a variety of roles associated with competitive and

---

\* Amity School of Physical Education and Sport Sciences, Amity University, Noida, India

\*\* Amity School of Physical Education and Sport Sciences, Amity University, Noida, India

non-competitive sports, in addition to this highlighting the importance of inclusion within the Physical Education environment. "Sport education includes the development of sport skills, an understanding of rules, strategies and tactics of various sports and an appreciation of codes of behavior". Adapted from - Ministry of Education, 1987.

Sport can be defined as vigorous physical activity which discovering the limit one's capabilities, or for fun, amusement and diversion, involves competition against oneself or another, (Moneghetti Report). Sport is an activities or development including physical exertion and skill in which an individual or gathering goes up against another or others for entertainment and amusement. Sport is by and large perceived as arrangement of exercises which base on physical physicality or physical skill Sport is generally recognized as system of activities which base on physical physicality or physical expertise. Some play wear, some are game fan, and some are game coordinators which are all advancing the game in different and various ways. (Barnes, 2006) Largely thanks to television, sport has become part of human culture to an extent once inconceivable. As Mihir Bose, the Daily Telegraph columnist puts it: 'We have lost religion and found sport.' Newspaper sports pages have expanded and now occupy more space, even in up market papers, than 'world news'. (Barnes, 2006)

### **Material and Methods**

Many studies completed on the sport promotion and development has been conducted across the global. Sports can be developed and promoted through various activities engaging the sports reviews have shown sport tourism, league, marketing development etc. taken place for the development and promotion of sport. Many experts speak about the sports promotion with related to many, Sports goods, Goods Manufacturing, sport sponsorship, sponsor recall, sponsor link market, mega sport event, emerging sport nation, sports Career, sport opportunities and trends, sport market Physical Education, Sports personalities, sport tourism. Etc.

### **Variable**

- **Sports Fan**
- **Physical Education and Sport**
- **Fitness and GYM**
- **Sports Tourism**
- **Sport Career**
- **Sports Retail**

### ***Sports Fan***

Reviews Sports market has been focus on how to get more fans in the seats at the specific sport venue by taking the type of product sold and level of sport integration into account on domain that are Spectators Sports Products, Participation Sports Products, Sports Apparel, Athletic Shoes & Sports – Related Products and Non-sports Products (Russel, 2015). Experts said that along with time sports fan, sports tourism and sports viewership has been increasing tremendously.

### ***Physical Education and Sport***

Information and training about directing fitness testing and managing data, students' knowledge and motivation, support and resources for conducting fitness assessments, and complexity of the fitness condition (Scott B. Martin) . The Experts commented that the Physical education in TGT and PGT level is increasing day by day. And there is significant

difference in the understanding of need and importance of physical education and its value in current period.

### ***Fitness and GYM***

Results demonstrated that pupils in the multi-activity unit spent somewhat more than the prescribed half of lesson time in direct to fiery physical movement while the understudies in the SE unit did not approach this level study contributes to the imperfect evidence on the impact of outdoor gyms on physical activity outcomes. (teaching, 2005) (PhilayrathPhongsavan, 2016). Whereas the experts are concerned, viewed and commented that the population is now more focus towards the understanding of fitness concept and hence there is an increment in the numbers of gym and fitness center and its user.

### ***Sports Tourism***

The reviews say that event sport tourism on Regional Economic Development the feature of hosting Event in Sports Tourism and using them as a regional development strategy. Sport Tourism suddenly become so prominent, a look back at history shows that people have engaged in sport related travel for centuries. However, in the past ten years, the popularity of this form of travel has increased. (Huei-Wen Lin) (J.Gibson). The expert had expressed their views on development of sports tourism and said that sports tourism has been increase.

### ***Sport Career***

As far as Sport Career is concerned the reviews says that there are pointlessness of formal instruction, quickened social versatility, the certainty of a moment profession, and the idea of athletic retirement are expounded. In addition to a more illustrative example of 606 occupants in inward Belfast. The findings demonstrate that game cooperation decays with age, yet so does the surrender rate, so reliability among the individuals who keep on being sports dynamic actually increase (Rosenberg, 1980) (K. Roberts, 1991). The expert expressed the positive indication towards job opportunities and their increasing rate. The Common Wealth Game and Khelo India had given the hike in the opportunity too. The involvement of project management companies and entrepreneurship has widened the area.

### ***Sports Retail***

According to the available reviews on sports retail many foreign and domestic cooperate retailers have entered into sports retailing and study also provide an overview of sports retail sector in India. An insightful and meaningful exposition into the opportunities and trends affecting small, medium, micro enterprises in the sports business industry in South Africa. . (Arprit Muherjee, 2010) (Mothilall K. , 2012). Experts commented that yes retailer has been increasing and many private companies has been developed, decathlon place vital role in sports retail.

### **Expert List**

Sl.	Name	Organization	Designation
1.	Gautam Mukherjee	Sportify Sports Education & Management Services Pvt. Ltd.	Co-Founder and CEO
2.	Mrs. Deepa Malik	Paralympic Shot-Put Player	International player & Padmashri Awardee
3.	Gur Sharan Singh	Steel Authority of India	Senior Manager former Indian cricketer Dronachary Awardee
4.	Prof Dilip Kumar dureha	LNIFE, Gwalior	Vice Chancellor
5.	Prof Sandeep Tiwari	IGI, New Delhi	HOD

## **Conclusion**

This paper is an attempt to identify the sport promotion and development and trends seen toward its development. From various experts interviewed and literature of reviews conducted has emphasized the value of sport in development and promotions. The various parameters associated with sport which is sport are Sports goods, Goods Manufacturing, sport sponsorship, sponsor recall, sponsor link market, mega sport event, emerging sport nation, sports Career, sport opportunities and trends, sport market Physical Education, Sports personalities, sport tourism. Etc.

## **Reference**

- AL-Busafi, M. (2012). Oman: An Emerging Sport Nation, History and Future directions. *International Journal of sport studies*, 233-242.
- Arprit Muherjee, R. G. (2010). Sports Retail in India: Opportunities constraint and way Forward”.
- Barnes, S. (2006). *Short book , The meaning of sports rarely scores an own goal, says Peter Wilby*.
- Getz, D., & Fairley, S. (2004). *media management at sport events for destination promotion: case studies and concepts*. Australia.
- Gibson, H. J. (1998). Sport Tourism : A Critical Analysis of Reseach .
- Government of India, M. o. (2011). *National Sport Development code of India*. New Delhi.
- Gupta, A. Y. (2015). *Branding through Sponsorship-Linked Marketing: A Case of Chinese Sports Apparel and Equipment Brand “Li Ning”*.
- Huei-Wen Lin, H.-F. L. (n.d.). The Evaluation of Event Sport Tourism on Regional Economic Development. *Excellence in Research and Innovation for Humanity*, 38-48.
- J.Gibson, H. (n.d.). “Sport Tourism: A Critical Analysis of Research”. In *Sport Management Review*.
- K. Roberts, J. H. (1991). ”Sporting Lives: A Case Study of Leisure Careers.
- kapoor, S. T. (2015). Constituents of successful sport league in Emerging Markets. *Indian Instituent of sucessful sports league in Emerging Market*, 1- 25.
- Kosava, A. K. (n.d.). *THE CONCEPT OF SPORT AND PHYSICAL EDUCATION*. Sport studies and fundamental terminology in English.
- Martin, S. B. (n.d.). Satewide Physical Fitness Testing .
- Moneghetti Report, 1. (n.d.).
- Moneghetti Report, 1. (2009). *TEACHING HEALTH, PHYSICAL AND SPORT EDUCATION. The Australian Council for Health, Physical Education and Recreation, Victorian Branch*.
- Mothilall, k. (2012). *an analysis of oppoertunities and trends in the sport business industry with a focus on entrepreneurship and small, medium, micro enterprises*.
- Mothilall, K. (2012). An analysis of Opportunities and Trends in the Sports Business Industry with a Focus on Entrepreneurship and Small, Medium, micro Enterprise.
- PhilayrathPhongsavan, M. V. (2016). mpact of an outdoor gym on park users’ physical activity: A natural experiment”.
- rajbhat, K. k. (2015). therole of sport sponsorship and brand management in global sports marketing. thiland.
- Rosenberg, E. (1980). Social Disorganizatio aspect of professional career.
- Russel, S. F. (2015). The Four Domains of Sports Marketing: A Conceptual Framework.

Santana-Gallego, J. F. (2011). *the impact of mega- sport event on tourist arrivals*. 13364-1370.

Scott B. Martin, A. E. (n.d.). *Statewide Physical Fitness Testing*. 2010.

teaching, M. B.-S.-r.-a. (2005). "Health-related fitness in sport education and multi-activity teaching.

wai, L. l. (n.d.). *Views on sport sponsorship in singapore*. Singapore.

Zhang, L. l. (2015). *Branding through Sponsorship-Linked Marketing: A Case of Chinese Sports Apparel and Equipment Brand "Li Ning"*. USA.



---

## **Knowledge Mining for Crime Control – A Case Study of Vehicle theft in Sirsa District**

**Dr. Omda Kumar\***

### ***Abstract***

*Various computing technologies have influenced processing of data and retrieval of information from the huge datasets. Of these technologies, Data Mining has been used to extract the knowledge from the vast data of vehicle thefts. To assess the effectiveness of predictive data mining in vehicle theft, a dataset relating to vehicle thefts in Sirsa district has been analysed and useful patterns have been extracted in the present study. The study has been reported in five sections. The first section states the introduction. Second section discusses knowledge mining from vehicle theft data. The third section describes the processing of the data. Results have been discussed in the fourth section which underlined the usefulness of data mining to predict and prevent the vehicle theft. The last section states the conclusion.*

**Keywords:** Data Mining, Association, Integrated Police Applications.

### **1. Introduction**

Computing technology has significantly influenced human life, business data processing as well as scientific computing. At early stages, computer professionals were concerned with designing files to store data and to explore information for various applications. Storage size and speed of accessing the data were the limitations. Era of database systems solved the problem of data storage. Responsibility like declarative aspects of programs was passed on to the database administrators and the users were facilitated to queries in simpler languages such as SQL. On the hardware side, the storage cost and machine cost have been reduced to affordable amount by the time. Now days, a large amount of data are being accumulated and stored as archival files. Hence, the electronic domes of organizations, research institutions and government departments are heaped up. Recently, with the help of tools of knowledge discovery and data mining, it has become relatively easier to analyse such huge data. Data mining deals with exploration and analysis of huge amount of data to discover meaningful patterns and rules [1]. In recent times, deposits of electronic information have grown dramatically due to cheap electronic and magnetic storage devices [2].

### **2. Knowledge Mining from Vehicle Theft Data**

In order to apply data mining techniques in crime detection, the related data should be stored in electronic form and contain descriptive information about the criminals. In case of a good match and the offenders being held for one or more offences, then possibility of each unsolved case indicates that these are also committed by the same criminal/group. By matching unsolved cases with known criminals, it would be possible to clear up old cases and determine patterns of behaviour. Alternatively, if the criminal is unknown but a large cluster of cases seem to point out the same offenders, then these frequent offenders are carefully examined [1]. Data Mining may play a vital role in crime prevention and criminal

---

\* Chaudhary Devi Lal University, Sirsa, Haryana, India

tracking. Effectiveness of data mining in crime detection has been discussed in the present work. Data of vehicle theft in Sirsa district has been analyzed to draw the inference and pinpoint the theft hotspots. Association technique of data mining has been used through Weka 3.7.7 to extract the useful knowledge.

Police in India are computerizing various processes using software like CIPA, CCIS, CCTNS and others. This software are helping a lot to the police for searching relevant record of the crime, criminals and other relevant information from time to time and also saving time and efforts. By using data mining, useful trends, patterns and behaviour among similar cases for making future planning can be established. In present study, a dataset relating to vehicle thefts in Sirsa district from 1<sup>st</sup> January, 2012 to 30<sup>th</sup> may, 2012 has been analysed and useful patterns have been extracted. Data are downloaded and normalized in Microsoft Excel worksheet and are processed through SPSS. Abstract of the dataset and its structure is shown in table 2.1 & 2.2, respectively.

**TABLE-2.1: Abstract of dataset of vehicle theft in Sirsa district**

Description	Value
Geographical Area of dataset	Sirsa district
Period	1 <sup>st</sup> Jan., 2012 to 30 <sup>th</sup> may, 2012
Total No. of instances	147
Missing values	No

Structure of the dataset is given as detailed in the below table-2.2:

**TABLE-2.2: Structure of dataset of vehicle theft in Sirsa district**

Name of Attribute	Category	Range/Value
PS	Numeric	1-12{RORI, CITYMANDIDABWALI, SIRSACITY, RANIA, SADARSIRSA, KALANWALI, ELLENABAD, DING, BARAGUDHA, MANDIDABWALISADAR, NSCHOPTA, ODHAN}
OccuTimeNormalized	Numeric	1-24 {31-130 = 1, 131-230 = 2, 231-330 = 3, ..... 2331-0030 = 24,}
OccuDay	Numeric	1-7{SUNDAY, MONDAY, TUESDAY, WEDNESDAY, THURSDAY, FRIDAY, SATURDAY}
BeatCode	Numeric	21-1018{Code of Police Station mentioned before the beat No.}
PropertyStolenInvolved	Numeric	1-8{MOTORCYCLE, SCOOTER, CAR, JEEP, TRACTOR, TRUCK, VAN, MINITRUCK}
Make	Numeric	1-15{MAHINDRA, SUZUKI, HONDA, HERO, TVS, BAJAJ, MARUTI, HUNDAI, SWARAJ, JOHNDEAR, ESCORT, TATA, LML, FORD, YAMAHA}
ManufacYear	Numeric	1947-2012

(Source: [http://haryanapolice.nic.in/police/fir\\_query\\_Stolen.asp](http://haryanapolice.nic.in/police/fir_query_Stolen.asp), accessed 23.11.2012) [3]  
 Attribute as police station: PS, normalized time of occurrence of vehicle theft : OccuTimeNormalized, day of occurrence of vehicle theft : OccuDay, beat code : BeatCode, property stolen : PropertyStolenInvolved, manufacturer of the vehicle : Make,

model : Model and year of the manufacturing of the vehicle : ManufacYear have been taken in the above data. Data related to various police stations of district Sirsa has been taken and time of theft ranging from 1 to 24 hours and normalized as 0:31-1:30 = 1, 1:31-2:30 = 2, 2:31-3:30 = 3, ..... 23:31-00:30 = 24. Day of theft range from Sunday to Saturday. Beat is the beat area of the police station ranging from 21 to 1018, code of police station is prefixed before the code of beat. Property stolen is motorcycle, scooter, car, jeep, tractor, truck, van and mini-truck. Make of the property stolen has been considered as Mahindra, Suzuki, Honda, Hero, TVS, Bajaj, Maruti, Hundai, Swaraj, John Dear, Escort, TATA, LML Ford and Yamaha. Year of manufacture is the year of manufacturing of the property stolen ranging from 1947 to 2012.

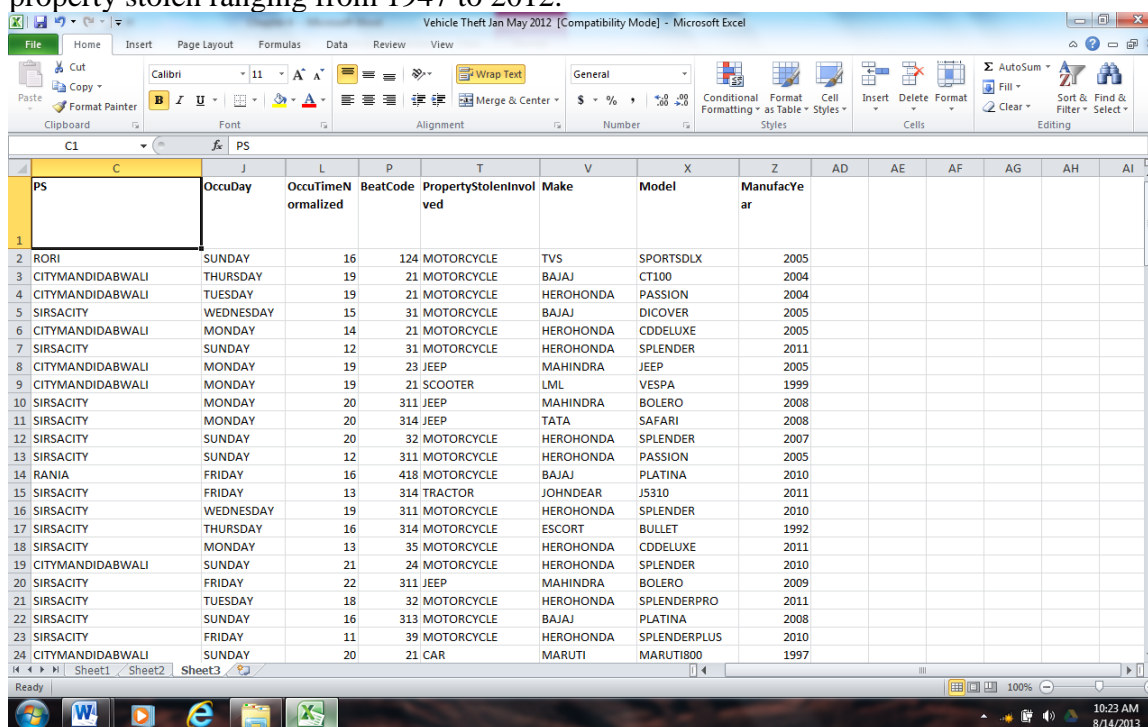

FIGURE -2.1 Snapshot of data in the MS Excel format

The above data show 147 cases of vehicle theft in police stations of Sirsa district from 1<sup>st</sup> January, 2012 to 30<sup>th</sup> May, 2012. Database has been created in MS Excel.

TABLE-2.3: Statistics of data of Vehicle Theft

	POLICESTATION	TIMEOFOCCU	BEAT	PROPERTYSTOLEN	MAK E	MODE L	OCCUDA Y
N	147	147	147	147	147	147	147
Mode	3.00	20.00	21.00	1.00	4.00	6.00	4.00
Std. Deviation	1.53571	4.55559	185.86722	1.19492	2.35079	8.61532	1.92212
Minimum	1.00	1.00	21.00	1.00	1.00	1.00	1.00
Maximum	10.00	23.00	1018.00	7.00	15.00	36.00	7.00

(Source: [http://haryanapolice.nic.in/police/fir\\_query\\_Stolen.asp](http://haryanapolice.nic.in/police/fir_query_Stolen.asp), accessed on 23.11.2012)

[3]

(Data Processed through SPSS 13.0 version)

### 3. Processing of Data

The data so normalized were converted to “.arff” file with the help of a file converter CeDiyez Excel2Arff Converter V.1.0 – Beta and then processed by using Association technique of data mining through Weka 3.7.7\*.

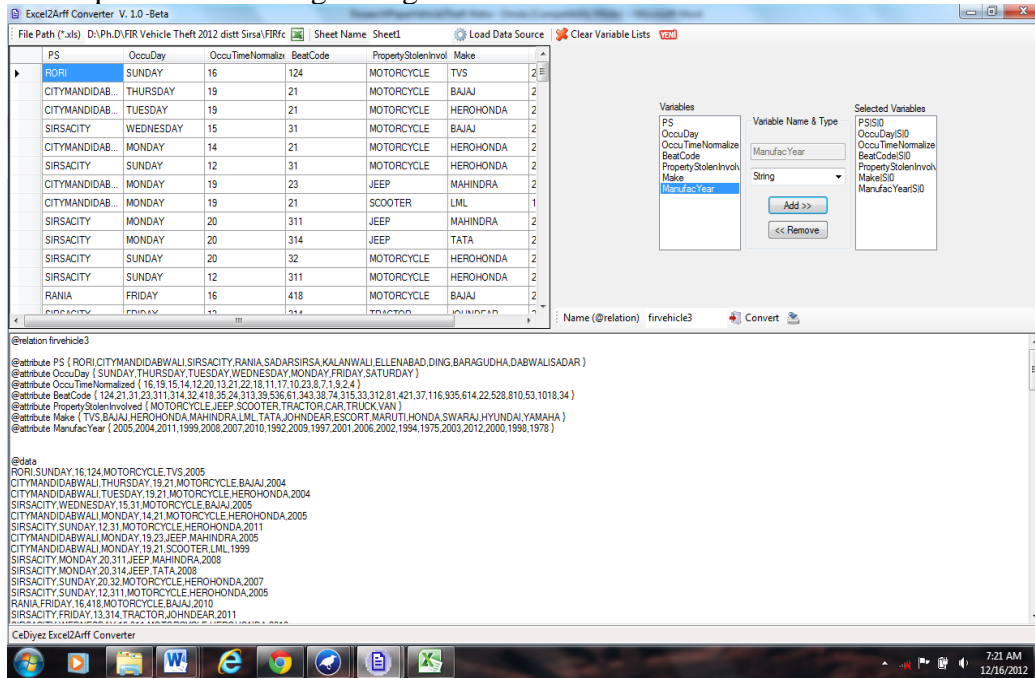

FIGURE -3.2 CeDiyez Excel2Arff Converters V.1.0 – Beta

The data converted to .arff file were processed in Weka using various data mining techniques. Following results have been received:

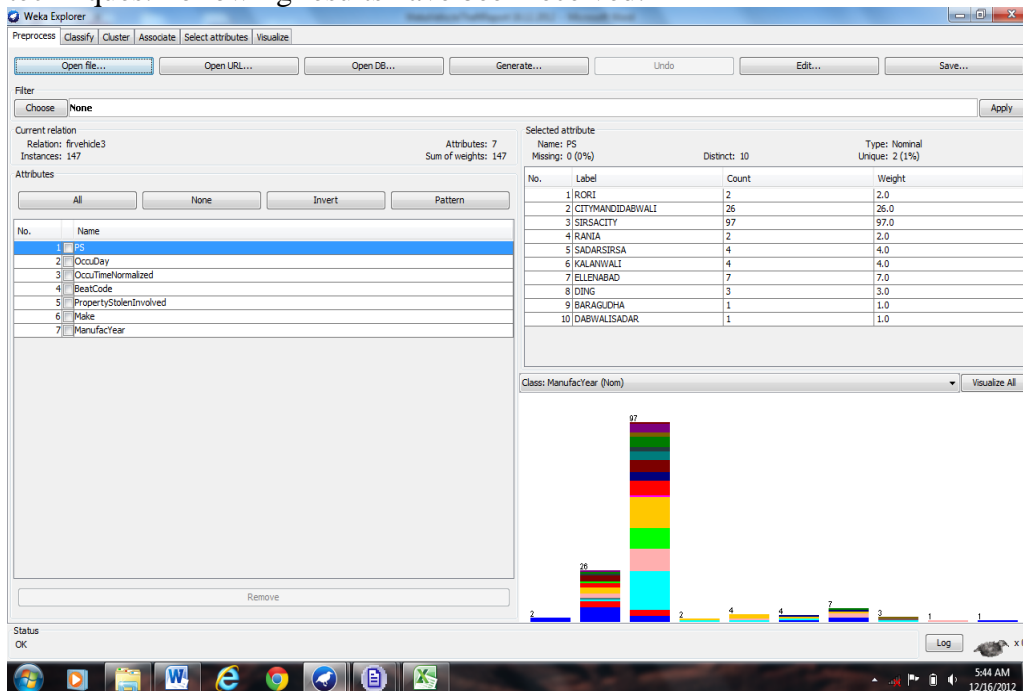

FIGURE -3.3: Weka main window showing processing of data

\*Weka 3.7.7 is data mining tool developed by the University of Waikato, Hamilton, New Zealand.

**TABLE 3.4: PS**

ZeroR predicts class value: SIRSACITY

a	b	c	d	e	f	g	h	i	j	<-- classified as
0	0	97	0	0	0	0	0	0	0	c = SIRSACITY
0	0	26	0	0	0	0	0	0	0	b = CITYMANDIDABWALI
0	0	7	0	0	0	0	0	0	0	g = ELLENABAD
0	0	4	0	0	0	0	0	0	0	e = SADARSIRSA
0	0	4	0	0	0	0	0	0	0	f = KALANWALI
0	0	3	0	0	0	0	0	0	0	h = DING
0	0	2	0	0	0	0	0	0	0	a = RORI
0	0	2	0	0	0	0	0	0	0	d = RANIA
0	0	1	0	0	0	0	0	0	0	i = BARAGUDHA
0	0	1	0	0	0	0	0	0	0	j = DABWALISADAR

Table 3.4 shows that the police station namely Sirsa City registered maximum First Information Reports (FIRs) which are 97 in absolute figure (66 per cent) followed by police station City MandiDabwali registered 26 FIRs (17.7 per cent) and Ellenabad registered 7 FIRs (4.8 per cent) in Sirsa district with a total of 147 cases of vehicle in 10 police stations from 1<sup>st</sup> January, 2012 to 30<sup>th</sup> May, 2012. On the other hand, Rori, Rania, Sirsa Sadar, Kalanwali and Ding police stations registered 1 to 3 per cent cases of vehicle theft, while single FIR has been registered in Baragudha and DabwaliSadar police stations in the above period. It is also noted that no case of vehicle theft has been registered in NathusariChopta and Odhan police stations during the above said period.

#### 4. Results by using Association

Association refers to the data mining task of uncovering relationships among data. The best illustration of data type of application is to determine association rules. An association rule is a model that identifies specific types of data associations. These associations are often used to identify items that are frequently occurred together. Users of association rules must be cautioned that these are not casual relationships. They do not represent any relationship inherent in the actual data or in the real world.

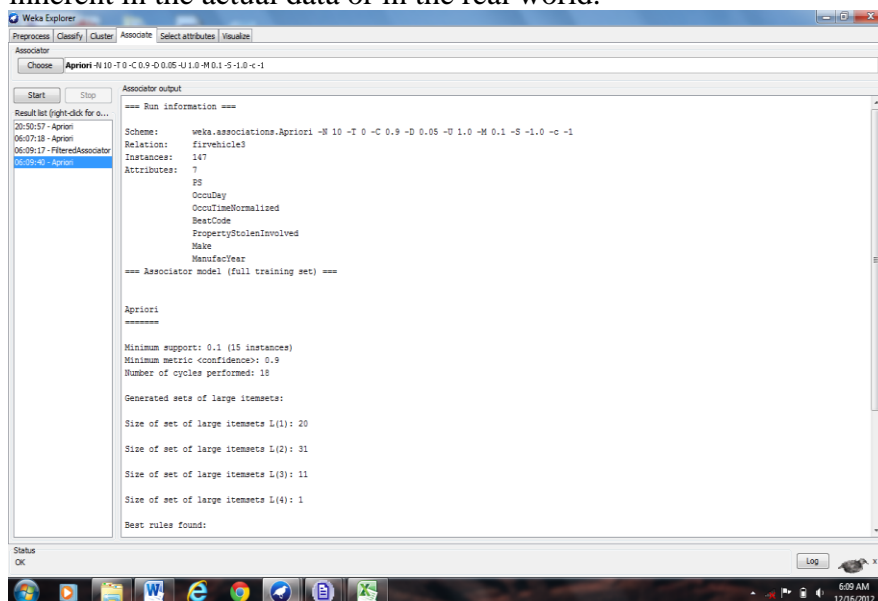

**FIGURE -4.4: Weka showing using Apriori in association technique**



Results generated by using Association technique of data mining have been detailed as under:-

Scheme: weka.associations.Apriori -N 10 -T 0 -C 0.9 -D 0.05 -U 1.0 -M 0.1 -S -1.0 -c -1

Relation: firvehicle3

Instances: 147

Attributes: 7

PS

OccuDay

OccuTimeNormalized

BeatCode

PropertyStolenInvolved

Make

ManufacYear

Apriori

=====

Minimum support: 0.1 (15 instances)

Minimum metric <confidence>: 0.9

Number of cycles performed: 18

Generated sets of large itemsets:

Size of set of large itemsetsL(1): 20

Size of set of large itemsetsL(2): 31

Size of set of large itemsetsL(3): 11

Size of set of large itemsetsL(4): 1

**TABLE-4.5: Best rules**

1. Make=HEROHONDA 76 ==>PropertyStolenInvolved=MOTORCYCLE 76  
<conf:(1)> lift:(1.26) lev:(0.11) [15] conv:(15.51)
2. PS=SIRSACITY Make=HEROHONDA 49  
==>PropertyStolenInvolved=MOTORCYCLE 49 <conf:(1)> lift:(1.26) lev:(0.07)  
[10] conv:(10)
3. BeatCode=21 23 ==> PS=CITYMANDIDABWALI 23 <conf:(1)> lift:(5.65)  
lev:(0.13) [18] conv:(18.93)
4. BeatCode=21 PropertyStolenInvolved=MOTORCYCLE 21 ==>  
PS=CITYMANDIDABWALI 21 <conf:(1)> lift:(5.65) lev:(0.12) [17]  
conv:(17.29)
5. OccuTimeNormalized=20 Make=HEROHONDA 19  
==>PropertyStolenInvolved=MOTORCYCLE 19 <conf:(1)> lift:(1.26) lev:(0.03)  
[3] conv:(3.88)
6. BeatCode=314 18 ==> PS=SIRSACITY 18 <conf:(1)> lift:(1.52) lev:(0.04) [6]  
conv:(6.12)
7. BeatCode=35 18 ==> PS=SIRSACITY 18 <conf:(1)> lift:(1.52) lev:(0.04) [6]  
conv:(6.12)
8. BeatCode=35 PropertyStolenInvolved=MOTORCYCLE 17 ==> PS=SIRSACITY  
17 <conf:(1)> lift:(1.52) lev:(0.04) [5] conv:(5.78)
9. PS=CITYMANDIDABWALI Make=HEROHONDA 16  
==>PropertyStolenInvolved=MOTORCYCLE 16 <conf:(1)> lift:(1.26) lev:(0.02)  
[3] conv:(3.27)



---

**10.** BeatCode=35 Make=HEROHONDA 15 ==> PS=SIRSACITY 15 <conf:(1)>  
lift:(1.52) lev:(0.03) [5] conv:(5.1)

Out of 147 instances of vehicle theft in district Sirsa during the period 1<sup>st</sup> January to 30<sup>th</sup> May, 2012, it came out that maximum theft happened in the jurisdiction of Sirsa City police station; and these were the motorcycles which were manufactured by Hero Honda. Beatwise maximum theft happened in the area of Beat No. 1 of MandiDabwali City police station. Maximum thefts happened during the time of 19:31 to 20:30 hours of the day.

## **5 Conclusion**

At present, data are being actively collected and stored in large data-warehouses in most of the government and social organizations. It has become the necessity of the time to recognize the potential value of these data stores a source of knowledge for making useful and wise decisions. Data mining can cater to this requirement of decision support in every area of the enforcement agencies. The present research has discussed how data mining can help the police administration to explore the available datasets and draw relationship and patterns between occurrences. The results have underlined the usefulness of data mining to predict and proactively deter the events of thefts etc. Thus, need is to understand the recognized fact to explore and mine the available data-heaps to draw valuable information for decision making.

## **References**

- [1] Pujari, A.K. (2010). *Data Mining Techniques*. (Second Edition), Universities Press Private Limited, Hyderabad (India).
- [2] Gupta, G.K. (2008). *Introduction to Data Mining with Case Studies*. (Second Printing) Prentice Hall of India Private Limited, New Delhi, August.
- [3] [http://haryanapolice.nic.in/police/fir\\_query\\_Stolen.asp](http://haryanapolice.nic.in/police/fir_query_Stolen.asp) (accessed 23 Nov., 2012).
- [4] [http://ncrb.gov.in/All%20State%20RFP/Haryana/Haryana\\_CCTNS\\_SI\\_RFP\\_Vol\\_I.pdf](http://ncrb.gov.in/All%20State%20RFP/Haryana/Haryana_CCTNS_SI_RFP_Vol_I.pdf) (Accessed on August 10th, 2012)
- [5] <http://ncrb.nic.in/ccismle.htm>. (Accessed 28 July 2012)
- [6] Adriaans, P. and Zantinge, D. (2003). *Data Mining*. (Seventh Indian Reprint) Pearson Education.
- [7] Atkinson, M., et al. (2008). Advanced Data Mining and Integration Research for Europe. *A European Project*, 27<sup>th</sup> October.
- [8] Awad, M.; Khan, L.; Thuraisingham, B. and Wang, L. (2009). *Design and Implementation of Data Mining Tools*. CRC Press, Taylor & Francis Group.
- [9] Azevedo, A. and Santos, M.F. (2011). QMBE: A Data Mining Language for Business Intelligence. *International Journal of Data Mining and Emerging Technologies*, 1(1), pp. 22-29. May.
- [10] Berson, A. and Smith, S. J. (2011). *Data Warehousing, Data Mining & OLAP*. (21<sup>st</sup> Reprint) Tata McGraw Hill Education Private Limited, New Delhi.
- [11] Berzal, F., Cubero, J.C and Jimenez, A. (2009). The design and use of the TMiner component-based data mining framework. *ELSEVIER*, pp. 7882-7887.
- [12] Bhardwaj, K.K., and Maqaleh, B.M.A., (2005). Evolutionary Approach for Automated Discovery of Censored Production Rules. *World Academy of Science Engineering and Technology*, 10, pp. 147-152. ISSN 1307-6884, December.
- [13] Bradley, J.C. and Millspaugh, A.C. (2009). *Programming in Visual Basic 6.0*. (24<sup>th</sup> Reprint) Tata McGraw Hill Education Private Limited, New Delhi.

- [14] Cooper, D.R. and Schindler P.S., (2004). *Business Research Methods*. (5<sup>th</sup> Edition Reprint) TATA McGraw Hill, New Delhi.
- [15] Dorre, J.; Gerstl, P., and Seiffert, R., (1999). Text Mining: Finding Nuggets in Mountains of Textual Data”, *ACM*, pp. 398-401.
- [16] Dunham, M.H. (2011). *Data Mining – Introductory and Advanced Topics*. (Eighth Impression), Pearson Education.
- [17] Dwivedi, H., and Bhargava, D., (2008). An Uphill Journey in the Police Stations from Traditional System to Modern System: CIPA in Rajasthan. *E-Governance in Practice*, Poddar Institute of Management, Jaipur, pp. 145-161.
- [18] Eapen, A.G., (2004). Application of Data Mining in Medical Applications. University of Waterloo, Ontario, Canada, 2004.
- [19] Fayyad, U. M., Shapiro, G. P., Smyth, P. and Uthurusamy, R. (2010). *Advances in Knowledge Discovery and Data Mining*. (Second Printing) Prentice Hall of India Private Limited, New Delhi.
- [20] Firdhous, M.F.M. (2010). Automating Legal Research through Data Mining. *International Journal of Advanced Computer Science and Applications*, 1(6), pp. 9-16, December.
- [21] Fredrick, R. O. and Patrick, O. (2007). Survey of Data Mining Methods for Crime Analysis and Visualization”, Part 4: ICT and Legal Applications.
- [22] French, C.S. (1986). *Data Processing*. (Seventh Edition), Galgotia Book source, New Delhi, March.

#### **Author' biography with Photo**



Dr. Omda Kumar is a research scholar of the Department of Computer Science & Applications, Chaudhary Devi Lal University, Sirsa. Presently, he is working as a Deputy Superintendent in Chaudhary Devi Lal University, Sirsa. He completed his Ph.D. in Computer Science & Engineering from Chaudhary Devi Lal University, Sirsa. His topic of research is Study and Design of Some Data Mining Tools for Judiciary and Police Administration.

## **A Study on Motivation of Employees in the Digital Age**

**Dr.S.Yuvaraj\***

**Ms. Sheila Eveline. N\*\***

### **Abstract**

Study on motivation is one of the important areas in the field of organisational behaviour. It deals with understanding the emotions, behaviour of the individuals or a group within the organisation. Based on these understanding, the organisation has to satisfy their needs. Motivation is a tool which helps to stimulate the expected action from the employees. For an organisation, employees are said to be one of the important asset. This asset can be retained only by a tool called motivation. In the digitalised economy motivation is very important. Advancement in technology acts as both blessing and a curse for the employees. Therefore, this study is an attempt to understand the role of motivation in the digital age by synthesizing the existing literatures and surveys. From the study it was understood that old theories have to be updated based on the current changes in work environment to retain the employees for sustaining the organisational growth.

**Keywords:** Motivation, digitalisation, technology, motivational methods.

### **Introduction**

The study on human behaviour within the organisation is known as organisational behaviour. The important aspect in the study of organisational behaviour is the motivation of the employees. Motivation is a combination of forces such as social, emotional, biological which induces an individual to behave. Motivated employees have a drive to succeed while employees who are unmotivated are less worried about their organisation and their performance. There are three key elements of motivation such as intensity which is the ability a person tries to be focused or more concentrated, direction which stimulates the individuals to act and persistence is the ability to sustain even if there is obstacles to accomplish the goals. Therefore, in the current competitive business environment motivated employees are needed for the organisation to be successful. But with the increase in the digitalization, the role of technology has witnessed an enormous transformation. Artificial Intelligence, Big data, robotics, Internet of Things, automation, etc., has changed the job role of the employees and also the work environment. Therefore, it is a challenging task for the organisation to understand the employee's behaviour in the changing digital economy. It is the duty of the employers to motivate their employees to customize themselves with these changes.

### **Theories of motivations**

According to F.W. Taylor people are generally motivated by money. But in Hawthorne study says that social need is more important than economic need. Therefore to understand the need and to motivate the people by 1950s several theories were developed on motivation such as Abraham Maslow's need hierarchy theory, Frederick Herzberg's two factor theory (hygiene and motivational factor), McGregor's X and Y theory, Alderfer's

---

\* Assistant Professor, Department of Commerce, University of Madras, Chennai- 5

\*\* Ph.D. Research Scholar, Department of Commerce, University of Madras, Chennai- 5

ERG (Existence, Relatedness, Growth) theory, McClelland's theory of need (achievement, power, affiliation), Vroom's expectancy theory, Porter and Lawler's theory of individual difference, Adam's equity theory, Edwin Locke and Gary Latham's goal setting theory, reinforcement theory (positive and negative reinforcement, punishment, extinction), Ouchi's Z theory. According to Kanfer, R. (1992) theories of motivation were grouped based on need or personality, cognitive choice, goals or self-regulation, motives perspectives.

Nohria, N. et al. (2008) in Harvard Business Review has come up with new model of employees motivation based on four human drives such as acquire, bond, comprehend and defend. All these theories were developed keeping in view of employee's psychology based on needs, satisfaction and work environment which will ultimately increases the performance.

### **Importance of motivation**

Employee motivation is an important element for both organisation and for an individual. Because motivated employee develop themselves and also the organisation. They are more committed; increase the performance and productivity of the organisation. According to Badubi, R. M. (2017) employees are said to be an important asset in the organisation, there should be motivation without which it might lead to depression, turnover, and burnout. This can disrupt the success of the organisation. Zamecnik, R. (2014) says that designing and implementing effective motivational programme is a key role for every enterprise. It should be based on the on-going need which may change overtime. The preference of employees motivation changes based on the different circumstances. Wiley, Carolyn. (1997) understood in the study of motivation over 40 years that, in the survey during 1946, 1980, 1986, 1992 shows that appreciation, interesting work, good wages was the most important motivational factor and it was also found that over 40 years motivational values, changes according to the employment status, gender, income and occupation. Motivating an individual differ from organisation to organisation and from employee to employee. Hackman, J. R., & Oldham, G. R. (1976) infers that motivation depends on the psychological state of the employee, characteristic of job, attitude of the individual in responding to complex and challenging job.

### **Why motivation is necessary for the employees in digital age**

Motivating the employees is becoming very crucial especially in this digital age. In the current scenario the old motivational methods are hard to exist. Because of the advancement in the technology, there are unusual changes in the work environment. Most of the organisations were automated and routine tasks replaced by robots and artificial intelligence. And researches have proved that in years to come humans will be replaced by the machines. This lead to fear in the minds of every employee that they might lose their jobs in future. And this fear might leads to poor performance due to lack of concentration or pressure for updating with new skill requirements to match with the developments. The stress involved in these technological changes affects the employees performance. According to Nice, T. (2016) says that digital economy has a dramatic impact in the work environment were traditional operating models begin disrupted by technological changes and it is a challenge for managing and motivating the future workforce of millennial.

Today, with the development of technology in every sector, employees were demanded with high skill requirements. According to the study earlier 20 people were employed for

every million dollar business but now there were only 15 people employed. Current employees or new hiring employees are given a pressure to update their skills with the requirements of digitalisation to sustain for a longer period with the organisation. It depends on the management to understand the fear of employees and to motivate and support them to adapt and manage with the changing technology. Therefore, a worker friendly organisation will motivate and also increases employee's commitment.

### **Motivational methods in the digital age**

There are many ways to motivate employees with the help of technology. Gutierrez, K. (2016) says that companies should use technology to encourage workers to work virtually this might make them happier and more motivated. And it was also said that proper use of technology can motivate and empower the workers to be more flexible and engaged. According to Nigam, S. (2017) introduction of gamification mechanism in the business environment in the current scenario, which works as the psychology of motivation for the employees to boosts their competence. Only the best gamification mechanism should be introduced in training and development programs which is a kind of intrinsic motivation while providing rewards. Similarly Straz, M. (2015) says that the employees can be motivated with the help of mobile application by providing them to access company's documents even outside office this makes them more flexible. And also by providing automated review process which gives instants feedback and motivate the employees in right direction. With the increase in the usage of social networking sites management can create a social networking platform and post the achievements of the employees and appreciate their success. And also organisations can create eLearning mobile application which could help the employees to learn and update their knowledge with the current trends in automated working world. Development of technology induces individual's innovativeness and involvement, ultimately has a positive effect on the intrinsic and extrinsic motivation (Chang, C., & Chin, Y. 2011). Therefore, with help of the advancement in the technology, management can use this to motivate the employees to be committed and increase the organisational effectiveness.

### **Conclusion**

Motivation is one of the important factors which every employees needs in order to sustain and to produce profitability for the organisation. Motivations not always related to financial rewards also non-financial rewards. With the increase in the digitalisation the old theories of motivations has to be updated. There should be new ways to motivate employees both by using technology and by offering recreational activities, avail coupons, quick rewards for the work they do, etc. A profit oriented organisation will always motivate their employees to achieve the goals set. Therefore, from this study it was understood that it is a challenging task for the management to motivate employees in fast changing technological world. With the change in the technology every employee has two pressures to handle in terms of updating their skills constantly and fear of technology replacing humans. Only if the employees develop themselves they could sustain and engage in this competitive business world. These pressures create stress with the employees which will affect their performance. Due to lack of motivation for the employees to handle these pressure this might affect the stay of talented employees. Even employees should also have the willingness to accept the changes. Management can create an environment that would inspire strong employee's motivation. Thus, it is important to



develop the theories of motivation based on the current changes in work environment and encourage or motivate the employees of the organisation.

### References

1. Badubi, R. M. (2017). Theories of Motivation and Their Application in Organizations: A Risk Analysis. *International Journal of Innovation and Economic Development*, 3(3), 44-51. doi:10.18775/ijied.1849-7551-7020.2015.33.2004
2. Banks, L. (1997). *Motivation in the workplace: Inspiring your employees*. Virginia Beach, VA: Coastal Training Technologies.
3. Chang, C., & Chin, Y. (2011). Predicting the Usage Intention of Social Network Games. *Trans-disciplinary Marketing Concepts and Emergent Methods for Virtual Environments*, 195-204. doi:10.4018/978-1-4666-1861-9.ch013
4. Gutierrez, K. (2016, May 03). 5 Secrets to Increase Employee Engagement With Technology. Retrieved June 02, 2018, from <https://www.shiftelearning.com/blog/increase-employee-engagement-with-technology>
5. Hackman, J. R., & Oldham, G. R. (1976). Motivation through the design of work: Test of a theory. *Organizational behaviour and human performance*, 16(2), 250-279.
6. James, P.S. (2017). *Organisational Behaviour*. Pearson Education.
7. Kanfer, R. (1992). Work motivation: New directions in theory and research. *International review of industrial and organizational psychology*, 7, 1-53.
8. Nice, T. (2016, December 08). Sales force motivation and reward in a digital economy. Retrieved June 01, 2018, from <https://home.kpmg.com/au/en/home/insights/2016/12/motivating-rewarding-sales-force-in-digital-economy.html>.
9. Regi, S. B., Golden, S. A. R., & Franco, C. E. (2014). Employee Perception Towards Effectiveness Of Hr Practices In Public Sector Banks In Tirunelveli District. *Tactful Management Research Journal*, 2(6), 1-4.
10. Nohria, N., Groysberg, B., & Lee, L. E. (2008). Employee motivation. *Harvard business review*, 86(7/8), 78-84.
11. Nigam, S. (2017, August 22). Role of Gamification in Human Resources Management. Retrieved June 3, 2018, from <https://www.careerbuilderforemployers.co.in/blog/training-and-development-through-gamification/>
12. Saikia, G. (2018, June 04). 'Skill-shortage in IT sector alarming, 94% engineering graduates not hireable'. Retrieved June 4, 2018, from <https://www.newsbytesapp.com/timeline/Science/24248/110544/the-abysmal-scenario-in-india-s-it-sector>
13. Straz, M. (2015, February 23). 4 Ways to Use Technology in the Workplace to Motivate Employees. Retrieved June 01, 2018, from <https://www.entrepreneur.com/article/242961>
14. Stephen P. Robbins and Timothy A. Judge, *Organizational Behavior*, fifteenth edition, Pearson publication
15. Wiley, Carolyn. (1997). "What Motivates Employees According to over 40 Years of Motivation Surveys." *International Journal of Manpower*, vol. 18, issue 3, pp. 263-280, doi: 10.1108/01437729710169373.



16. Regi, S. B., & Golden, S. A. R. (2014). A Study On Attitude Of Employee Towards Working Environment With Special Reference To RR Pvt Ltd. *Review Of Research*, 2(2), 1.
17. Zamecnik, R. (2014). The measurement of employee motivation by using multi-factor statistical analysis. *Procedia-Social and Behavioural Sciences*, 109, 851-857.

## **Role of Public Distribution System in Rural Area- Study in Pune District Maharashtra**

**Dr .S.R. Bakhale\***

### **Abstract**

*In the present study studied that the Role of Public distribution system in rural area objective of this study is the quality of food providing by public distribution system for the rural area and their satisfaction for the system of food distribution. Null hypothesis have been considered in the present study. Descriptive research method respect to normative survey technique has been used in this study. Population of this study is 12 villages in Pune District state of Maharashtra simple random sampling method has been adopt in this study. Data collection by the self constructed questionnaire and analysis for this frequency distribution, percentage and chi square test etc. finding of the study indicated that the public distribution system in rural area on going the significant role for the food quality providing by the people and their satisfaction.*

### **1.1 Introduction**

The Public Distribution System evolved as a system of management of scarcity and for distribution of food grains at affordable price. Public Distribution System is one of the most important public intervention programmes to enhance food security in India and therefore, the success of National Food Security will critically depend upon efficient functioning of Public Distribution System. Public Distribution System provides rationed amount of basic food items and other non-food items at subsidized prices to consumers through a network of "fair price shops". Since 1972 poverty has been defined on basis of the money required to buy food worth 2100 calories in urban areas and 2400 calories in rural areas. A government committee headed estimated 50% Indians were poor as against Planning Commission's 2006 figure of 28.5%. Poverty is one of the main problems which have attracted attention of sociologists and economists. It indicates a condition in which a person fails to maintain a living standard adequate for his physical and mental efficiency. It is a situation people want to escape. It gives rise to a feeling of a discrepancy between what one has and what one should have. The term poverty is a relative concept. It is very difficult to draw a demarcation line between affluence and poverty. According to Adam Smith - Man is rich or poor according to the degree in which he can afford to enjoy the necessaries, the conveniences and the amusements of human life. The aim of the Public Distribution System was to target the poorest households by differentiating the access quantities and prices at which one is allowed to buy. The differentiation was achieved by classifying the beneficiaries into Above Poverty Line (APL), Below Poverty Line (BPL) or Anthyodaya households based their economic status, assessed based on the state-specific poverty lines.

### **1.2 Need of the study**

India's Public Distribution System is the largest distribution network of its kind in the world. Public Distribution System was introduced around World War II as a war-time rationing measure. Before the 1960s, distribution through Public Distribution System was

---

\* HOD, Dept of commerce, Annasaheb Awate college , Manchar Tal - Ambegaon, Distt.Pune [Maharashtra] PIN -410503

generally dependant on imports of food grains. It was expanded in the 1960s as a response to the food shortages of the time subsequently, the government set up the Agriculture Prices Commission and the Food Corporation of India to improve domestic procurement and storage of food grains for Public Distribution System. By the 1970s, Public Distribution System had evolved into a universal scheme for the distribution of subsidised food. In the 1990s, the scheme was revamped to improve access of food grains to people in hilly and inaccessible areas, and to target the poor. Subsequently, in 1997, the government launched the Targeted Public Distribution System with a focus on the poor. Public Distribution System aims to provide subsidised food and fuel to the poor through a network of ration shops. Food grains such as rice and wheat that are provided under Public Distribution System are procured from farmers, allocated to states and delivered to the ration shop where the beneficiary buys his entitlement. The centre and states share the responsibilities of identifying the poor. Public Distribution system is important role for the food distribution in rural Area for the above and below poverty line people respect to control price of dally needed in the present study identified that the satisfaction of the rural poor on the base of public distribution system respect to Pune District in the state of Maharashtra.

### **1.3 Objective of the study**

1. To study the Quality of food providing the Public Distribution System for the rural people.
2. To study the level of satisfaction of the rural people respect to public Distribution system providing foods in rural Area.

### **1.4 Hypothesis of the study**

1. There is no significant difference between the qualities of food providing by public Distribution system in rural Area.
2. There is no significant difference between the level of satisfaction of rural people respect to public distribution system providing food.

### **1.5 Scope and De-limitation of the Study**

The present study have conducted in Pune District in the state of Maharashtra in this study studied that the quality of food providing by public distribution system in rural Area and the level of satisfaction of the rural people respect to this public distribution system.

### **1.6 Methodology of the study**

In the present study Normative survey method have been use and collect the necessary primary data in this study geographical Area. In this study Area total 12 village has been selected the present study on the simple random sampling method and those every village public distribution system visit by investigator on the time present all person on the public distribution shop have been selected for the data collection. Total 120 people were considered for the data collection. The data collection for this study on the base of Questionnaire. Than analysis and interpretation of the data and conclude the main finding and conclusion of the study.

### **1.7 Analysis and Interpretation of Data**

**H0- 1. There is no significant difference between the qualities of food providing by public Distribution system in rural Area.**

Quality of foods	SC	ST	OBC	Open	Total	Fe	Chi-Square
Very High Quality foods	04 (16.00%)	01 (9.00%)	02 (6.25%)	07 (13.46%)	14 (11.67%)	2.917	113.277**
High Quality foods	06 (24.00%)	03 (27.27%)	07 (21.87%)	11 (21.15%)	27 (22.50%)	5.625	233.079**
Moderate Quality foods	08 (32.00%)	04 (36.36%)	14 (43.75%)	26 (50.00%)	52 (43.33%)	10.832	343.195**
Low Quality foods	05 (20.00%)	02 (18.18%)	04 (12.50%)	05 (9.62%)	16 (13.33%)	3.332	186.637**
Very Low Quality foods	02 (08.00%)	01 (9.00%)	05 (15.63%)	03 (5.77%)	11 (9.17%)	2.292	116.744**
<b>Total</b>	<b>25 (100%)</b>	<b>11 (100%)</b>	<b>32 (100%)</b>	<b>52 (100%)</b>	<b>120 (100%)</b>		

\* Significant difference on 0.01 Level for 3 Df

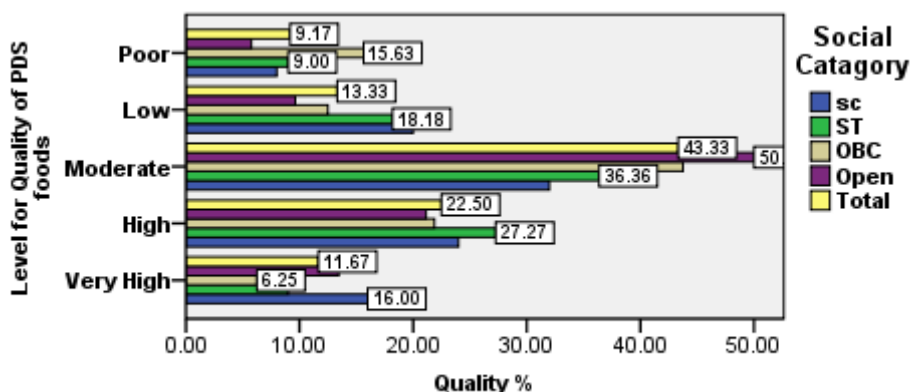

From the above table show that, quality of food providing by the public distribution system indicate that, 11.67% People given the opinion that he getting the very high quality food by PDS, the community wise distribution indicate that SC 16.00%, ST 9.00%, OBC 6.25%, and Open 13.46% People having the very good quality food providing by PDS. On this frequency see the significant difference to chi square test, the calculated chi Square value is 113.277 on the DF 3, this calculated chi square value is significant at 0.01 level. It's indicated that, there is significant difference between the very high quality food distributions for the various social category people in rural area.

High quality food distribution in rural area indicated that, 22.50% People given the opinion that he consumes the high quality food by PDS, the community wise distribution indicate that SC 24.00%, ST 27.27%, OBC 21.87%, and Open 21.15% People consume the good quality food providing by PDS. On this distribution of frequency see the significant

difference to chi square test, the calculated chi Square value is 233.079 on the DF 3, this calculated chi square value is significant at 0.01 level. it's indicated that the significant difference between the high quality food distribution for the various social category people in rural area.

Moderate quality food distribution in rural area indicated that the total 43.33% People given the opinion that he consumes the Moderate quality food by PDS, the community wise distribution indicate that SC 32.00%, ST 36.36%, OBC 43.75%, and Open 50.15% People consume the Moderate quality food providing by PDS. On this distribution of frequency see the significant difference to chi square test, the calculated chi Square value is 343.195 on the DF 3, this calculated chi square value is significant at 0.01 level. it's indicated that the significant difference between the moderate quality food distribution for the various social category people in rural area.

Low quality food distribution in rural area indicated that the total 13.33% People given the opinion that he consumes the Low quality food by PDS, the community wise distribution indicate that SC 20.00%, ST 18.18%, OBC 12.50%, and Open 9.62% People consume the Low quality food providing by PDS. On this distribution of frequency see the significant difference to chi square test, the calculated chi Square value is 186.637 on the DF 3, This calculated chi square value is significant at 0.01 level. it's indicated that the significant difference between the Low quality food distribution for the various social category people in rural area.

Very low quality food distribution in rural area indicated that the total 9.17% People given the opinion that he consumes the very low quality food by PDS, the community wise distribution indicate that SC 8.00%, ST 9.00%, OBC 15.63%, and Open 5.77% People consume the low quality food providing by PDS. On this distribution of frequency see the significant difference to chi square test, the calculated chi Square value is 116.744 on the DF 3, this calculated chi square value is significant at 0.01 level. It's indicated that the significant difference between the very low quality food distribution for the various social category people in rural area.

**H0- 2. There is no significant difference between the levels of satisfaction of rural people respect to public distribution system providing food.**

Level of satisfaction	SC	ST	OBC	Open	Total	Fe	Chi-Square
Very High satisfaction	03 (12.00)	01 (9.09)	03 (9.38)	07 (13.46)	14 (11.67)	2.917	93.771
High satisfaction	05 (20.00)	01 (9.09)	06 (18.75)	11 (21.15)	23 (19.17)	4.792	148.615
Moderate satisfaction	10 (40.00)	05 (45.45)	15 (46.88)	26 (50.00)	56 (46.67)	11.667	398.853
Low satisfaction	04 (16.00)	02 (18.18)	04 (12.50)	05 (9.62)	15 (12.50)	3.125	167.198
Very Low satisfaction	03 (12.00)	02 (18.18)	04 (12.50)	03 (5.77)	12 (10.00)	2.50	178.722
<b>Total</b>	<b>25 (100%)</b>	<b>11 (100%)</b>	<b>32 (100%)</b>	<b>52 (100%)</b>	<b>120 (100%)</b>		

\* Significant difference on 0.01 Level for 3 Df

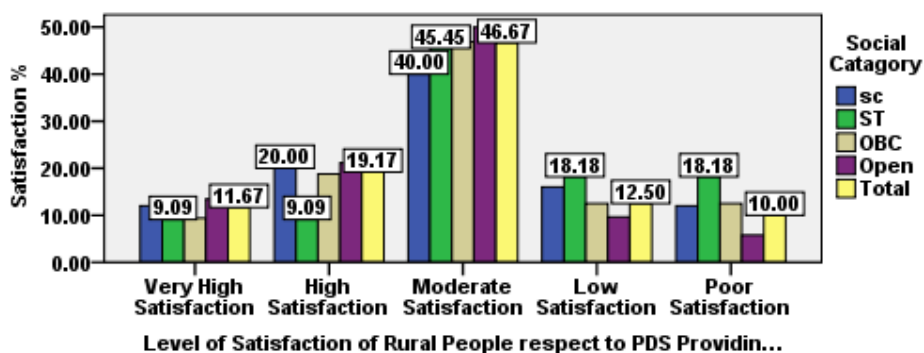

From the above table show that, Level of satisfaction of people respect to providing food by PDS. It's indicate that, 11.67% People given the opinion that he have been very highly satisfied for the food quality providing by the PDS, the community wise distribution indicate that SC 12.00%, ST 9.09%, OBC 9.38%, and Open 13.46% People have been very highly satisfied for the food quality providing by PDS. On this frequency see the significant difference to chi square test, the calculated chi Square value is 93.771 on the DF 3, this calculated chi square value is significant at 0.01 level. It's indicated that, there is significant difference between the very high satisfactions for the food quality providing by PDS in rural area.

High satisfaction of people respect to food, providing by PDS. It's indicate that, total 19.17% People have been highly satisfied for the food quality providing by the PDS, the community wise distribution indicate that SC 20.00%, ST 9.09%, OBC 18.75%, and Open 21.15% People have been highly satisfied for the food quality providing by PDS. On this frequency see the significant difference to chi square test, the calculated chi Square value is 148.615 on the DF 3, this calculated chi square value is significant at 0.01 level. It's indicated that, the significant difference between the high satisfactions for the food quality providing by PDS in rural area.

Moderate satisfaction of people respect to food, providing by PDS. It's indicate that, total 46.67% People have been Moderately satisfied for the food quality providing by the PDS, the community wise distribution indicate that SC 40.00%, ST 45.45%, OBC 46.88%, and Open 50.15% People have been moderately satisfied for the food quality providing by PDS. On this frequency see the significant difference to chi square test, the calculated chi Square value is 398.853 on the DF 3, this calculated chi square value is significant at 0.01 level. It's indicated that, the significant difference between the moderately satisfaction for the food quality providing by PDS in rural area.

Low satisfaction of people respect to food, providing by PDS. It's indicate that, total 12.50% People have been low satisfied for the food quality providing by the PDS, the community wise distribution indicate that SC 16.00%, ST 18.18%, OBC 12.50%, and Open 9.62% People have been low satisfied for the food quality providing by PDS. On this frequency see the significant difference to chi square test, the calculated chi Square value is 167.198 on the DF 3, this calculated chi square value is significant at 0.01 level. It's indicated that, the significant difference between the low satisfactions for the food quality providing by PDS in rural area.

Very Low satisfaction of people respect to food, providing by PDS. It's indicate that, total 10.00% People have been very low satisfied for the food quality providing by the PDS, the community wise distribution indicate that SC 12.00%, ST 18.18%, OBC 12.50%, and



Open 5.77% People have been very low satisfied for the food quality providing by PDS. On this frequency see the significant difference to chi square test, the calculated chi Square value is 178.722 on the DF 3, this calculated chi square value is significant at 0.01 level. It's indicated that, the significant difference between the very low satisfactions for the food quality providing by PDS in rural area.

### **1.8 Finding**

- There is significant difference between the very high Quality foods Distribution by PDS in rural area respect to various social category people. it is Schedule cast person percentage is very high and Schedule tribe person percentage is very low compare to other backward cast and general social category people opinion for the quality of food distribution by PDS in rural area.
- There is significant difference between the high Quality foods Distribution by PDS in rural area respect to various social category people. it is ST person percentage is very high and general category person percentage is very low compare to other social category people opinion for the high quality of food distribution by PDS in rural area.
- There is significant difference between the moderate Quality foods Distribution by PDS in rural area respect to various social category people. It is general category person percentage is very high and SC category person percentage is very low compare to other social category people opinion for the moderate quality of food distribution by PDS in rural area.
- There is significant difference between the Low Quality foods Distribution by PDS in rural area respect to various social category people. it is SC category person percentage is very high and general category person percentage is very low compare to other social category people opinion for the low quality of food distribution by PDS in rural area.
- There is significant difference between the very Low Quality foods Distribution by PDS in rural area respect to various social category people. It is OBC category person percentage is very high and general category person percentage is very low compare to other social category people opinion for the very low quality of food distribution by PDS in rural area.
- There is significant difference between the very high satisfactions of food Distribution by PDS in rural area respect to various social category people. it is general category person percentage is very high and ST category person percentage is very low compare to other social category people respect to very high satisfaction of food distribution by PDS in rural area.
- There is significant difference between the high satisfactions of food Distribution by PDS in rural area respect to various social category people. it is general category person percentage is very high and ST category person percentage is very low compare to other social category people respect to high satisfaction of food distribution by PDS in rural area.
- There is significant difference between the moderate satisfactions of food Distribution by PDS in rural area respect to various social category people. it is general category person percentage is very high and SC category person percentage is very low compare to other social category people respect to moderate satisfaction of food distribution by PDS in rural area.
- There is significant difference between the low satisfactions of food Distribution by PDS in rural area respect to various social category people. it is SC category person

percentage is very high and general category person percentage is very low compare to other social category people respect to low satisfaction of food distribution by PDS in rural area.

- There is significant difference between the very low satisfactions of food Distribution by PDS in rural area respect to various social category people. it is ST category person percentage is very high and general category person percentage is very low compare to other social category people respect to very low satisfaction of food distribution by PDS in rural area.

### **1.9 Conclusion**

Public distribution system in rural area providing the quality of food indicated that the total 11.67% People gating the very high quality food by PDS. 22.50% rural people gating High quality food by PDS, 43.33% People gating Moderate quality food by PDS, 13.33% people gating low quality food by PDS and 9.17% people getting very low quality food by PDS. On the other hand satisfaction of the rural people respect to public distribution system system providing food quality and regularity it's indicated that, 11.67% People in rural area having the very high satisfaction for the food providing by PDS, 19.17% people having high satisfaction by PDS, 46.67% people having moderate satisfaction by PDS, 12.50% people having low satisfaction by PDS and 10.00% people having very low satisfaction for the food providing by PDS in rural area. For the above discussion, conclude that the public distribution system in rural area has been providing the significant role of food distribution in rural area.

### **Bibliography**

- Atkinson, Anthony B., (1987), "On the Measurement of Poverty,"
- Bhalla, S.S. (2003), 'Recounting the Poor, Poverty in India 1983-1999', Economic and Political Weekly, Vol. 38, No. 4.
- Balakrishnan, P., & Ramaswami, B. (1997). Quality of Public Distribution System: Why it Matters. Economic and Political Weekly.
- Deaton, A. (2003). Prices and Poverty in India, 1987-2000. Economic and Political Weekly, 38 (4).
- Kabra, K.N. and Ittyerah A (1992); The Public Distribution System in India, Eastern books, New Delhi
- Kapil Kumar. (2017). Research Method in Data Science. Jaipur: Lal Publication.
- Mehta, Jaya (2004). 'Poverty in India', Alternative Economic Survey 2003-4, Rainbow Publishers, New Delhi.
- Minhas, B.S., L.R. Jain and S. D. Tendulkar (1991); "Declining incidence of poverty in the 1980s: Evidence versus aretefacts", Economic and Political Weekly, Vol. XXVI.
- Radharkrishna, R., & Subbarao, K. (Eds.). (1997). India's Public Distribution System: A National and International Perspective (Vol. 380). World Bank Publications.
- Patil A. (2017). Role of Public Distribution system in rural welfare. Amravati: N.B. Publication.
- Tata Economic Consultancy Services (1998): Study to Ascertain the Extent of Diversion of PDS Commodities.

## उपनिषदों में विद्या एवं अविद्या का स्वरूप

**Dr Sunita\***

वेद समस्त विद्याओं अर्थात् आधिभौतिक, आधिदैविक तथा आध्यात्मिक ज्ञान का कोष ग्रंथ है। उनका प्रत्येक अक्षर ज्ञान से भरा हुआ है। वेदों द्वारा बताए गए मार्ग पर चलकर ही मनुष्य अपने जीवन को सार्थक बना सकता है। वेद यद्यपि ज्ञानार्थक है, किन्तु ज्ञान की वास्तविक धारा हमें उपनिषदों में दृष्टिगोचर होती है, इसीलिए वेद- परम्परा में उपनिषदों को वेदान्त कहा गया है। ज्ञान का रहस्य उपनिषदों में उपलब्ध है।

उपनिषदों में दो प्रकार की विद्याओं का बोध होता है – परा और अपरा। 'परा' विद्या वह है जिससे अक्षर ब्रह्म का ज्ञान होता है। 'अपरा' विद्या वह है जिससे ब्रह्म से अवर प्रकृति का ज्ञान होता है। द्वे विद्ये वेदितव्य इति ह्यस्मद् ब्रह्मविदो वदन्ति परा चैवापरा च। तत्रापरा ऋग्वेदो यजुर्वेदः सामवेदोऽथर्ववेदः शिक्षा कल्पो व्याकरणं निरुक्तं छन्दो ज्योतिषमिति। अथ परा यथा तदक्षरमधिगम्यते।<sup>४</sup> प्रस्तुत मन्त्रों में 'विद्या' से पराविद्या और 'अविद्या' से अपरा विद्या अभिप्रेत हैं। अपने यजुर्वेद भाष्य में इस मन्त्र के अन्तर्गत 'अविद्यामुपासते' का अर्थ करते हुए स्वामी दयानन्द ने लिखा है कि परमेश्वर से भिन्न भौतिक पदार्थों की उपासना करना व उनमें रमे रहना अविद्या है। अविद्येति ज्ञानादिगुणरहितं वस्तु कार्यकारणात्मकं जड़ं परमेश्वराद् भिन्नम् अभ्यस्यन्ति।<sup>५</sup> कठोपनिषद् के अनुसार – आत्मज्ञान ही विद्या है और पेश अविद्या। अविद्या से हमें लौकिक सुख भले ही प्राप्त हो जायें, परन्तु अनन्त और वास्तविक आनन्द तो विद्या से ही उपलब्ध हो सकता है। जो मनुष्य विद्या से रहित है, वह न तो स्वयं कल्याण के मार्ग पर चल सकता है और न ही दूसरों का मार्ग प्रदर्शन कर सकता है –

अविद्यायामन्तरे वर्तमाना स्वयं धीराः पण्डितम्मन्य मानाः।

दन्द्रम्यमाणा परियन्ति मूढा अन्धेनैव नीयमानायथान्धाः।।<sup>६</sup>

ईषावास्योपनिषद् का कहना है कि विद्या वही अच्छी होती है जो अच्छा फल दे, जो सत्य पर आधारित हो। क्योंकि मिथ्या या कपटपूर्ण होने पर तो वह विद्या अविद्या से भी अधिक अनर्थकारिणी हो जाती है।

अन्धन्तमः प्रविषन्ति येऽविद्यामुपासते।

ततो भूय इव ते तमो य उ विद्यायाँरताः।।<sup>७</sup>

विद्या श्रेय है और अविद्या प्रेय है। प्रेय से श्रेय अधिक उपादेय है। जो विद्या और अविद्या की भिन्न-भिन्न सिद्धियों को समझता है और अपने उच्चतर एवं एकमात्र लक्ष्य आत्मोपलब्धि से च्युत नहीं होता, वह दोनों का सदुपयोग करके लाभ उठा सकता है अर्थात् अविद्या से मृत्यु अर्थात् लौकिक कष्टों को दूर करके और इस प्रकार अपेक्षाकृत सुखपूर्वक विद्या का साधन करके अमृतत्व को प्राप्त कर सकता है।

अविद्याया मृत्युं तीर्त्वा विद्यायामृतमप्नुते।<sup>८</sup>

ईषावास्योपनिषद् के 10वें मन्त्र से यह स्पष्ट हो जाता है कि अविद्या कोई अन्य। विद्या का वह अर्थ नहीं जिसे प्रचलित अर्थों में विद्या कहते हैं, अविद्या का भी वह अर्थ नहीं जिसे प्रचलित अर्थों में अविद्या कहते हैं। अर्थात् विद्या – अविद्या को जैसा आम लोग समझते हैं। उपनिषदों में उनका वह स्वरूप नहीं है। वहाँ उनका कुछ और ही अर्थ है, वह क्या है ?

अन्यदेवाहर्विद्यया अन्यदेवाहुरविद्यया।

इति षुश्रुम धीराणां ये नस्तद् विचक्षिरे।।<sup>९</sup>

कठोपनिषद् के अन्तर्गत यम-नचिकेता का परिसंवाद प्रसिद्ध है। विद्या तथा अविद्या का एक भेद वहाँ स्पष्ट हो जाता है। यमाचार्य नचिकेता से कहते हैं – हे नचिकेता! विद्या और अविद्या दोनों एक-दूसरे के विपरीत हैं, तू विद्या का चाहने वाला है, क्योंकि तुझे विशयों के भोगों का कोई लालच नहीं।

\* Assistant professor in Sanskrit, Regional Centre Kharal, BPS University

<sup>४</sup> मुण्डको 1/1/4, 5

<sup>५</sup> स्वामीदयानन्द कृत यजु०

<sup>६</sup> कठो 1/2/5

<sup>७</sup> ईषा०/9

<sup>८</sup> ईषा०/14

<sup>९</sup> ईषा०/10

दूरमेते विपरीते विशूची अविद्यया या च विद्येति ज्ञाता।

विद्याभीषितं नचिकेतसं मन्ये न ते कामा बहवोऽलोलुपन्त।<sup>॥६॥</sup>

उपनिशदों की परा विद्या का मूल वेद में है। कठोपनिशद् के ऋषि की तो स्पष्ट घोशणा है कि मैं उसी ब्रह्म विद्या का उपदेश कर रहा हूँ जिसका वर्णन वेदों में किया है।

सर्वे वेदा यत्पदमामनन्ति .....

..... तत्ते पदं संग्रहेण ब्रवीम्योमित्येतत्।<sup>॥७॥</sup>

उपनिशद् केवल अध्यात्म-विद्या के ग्रंथ हैं, परन्तु वेदों में जहां ब्रह्मविद्या का मूल है वहां वे मनुष्य के लौकिक अथवा भौतिक जीवन के लिए अपेक्षित इतर ज्ञान का भी आदिश्रोत है।

छान्दोग्य उपनिशद् में नारद और सनत्कुमार का उपाख्यान है। नारद ने सनत्कुमार के पास जाकर कहा – भगवन् ! सब कुछ जानकर भी मेरी आत्मा अषान्त है। तनिक से षोक में भी मैं घबरा जाता हूँ। मुझे इस षोक-सागर से पार कीजिये। सोऽहं भगवः षोचामि तं मा भगवाञ्छोकस्य पारं तारयत्विति।<sup>॥८॥</sup> ज्ञान से मुक्ति हो जाती है। फिर, ज्ञानी होकर भी नारद दुःखी क्यों ? इसका रहस्य जानने के लिए सनत्कुमार ने कहा – जो कुछ तुम जानते हो उससे आगे तुम्हें शिक्षा दूंगा। इसलिए पहले यह बताओ कि अब तक तुमने क्या कुछ पढ़ा है ? यद्वेत्य तेन मोपसीद ततस्त ऊर्ध्वं वक्ष्यामीति स होवाच।<sup>॥९॥</sup> नारद ने उत्तर दिया – भगवन्। मैंने ऋग्वेद, यजुर्वेद, सामवेद, अथर्ववेद, इतिहास, पुराण तथा वेदों के अर्थविधायक ग्रंथ व्याकरण, निरुक्त आदि सब पढ़े हैं। इनके अतिरिक्त मैं पितृविद्या, राषिषिद्या, निधिषास्त्र, वाकोवाक्य, एकायन, देवविद्या, भूतविद्या, ब्रह्मविद्या, क्षेत्रविद्या, नक्षत्रविद्या, सर्पदेवजनक विद्या आदि सब कुछ पढ़ चुका हूँ।<sup>॥१०॥</sup> इतना कुछ जानकर भी नारद की आत्मा को षान्ति क्यों नहीं मिली ? इसका उत्तर उपनिशद् ने स्वयं नारद के मुख से इन षब्दों में दिलाया है – सब षास्त्र पढ़कर भी मैं मन्त्रवित् हो पाया हूँ, आत्मवित् नहीं। सोऽहं भगवो मन्त्रविदेवास्मि नात्मवित्।<sup>॥११॥</sup> सनत्कुमार ने यह सब सुनकर नारद से कहा जो कुछ तुमने पढ़ा है वह नामज्ञान है। इसका फल भी नाममात्र होगा। नामैवैतत् स यो नाम ब्रह्मेत्युपासते यावन्नाम्नो गतं तत्रास्य यथाकामचारो भवति।<sup>॥१२॥</sup>

जिसे उपनिशत्कार ने नाम मात्र का बोध या नाम ज्ञान कहा है, वह अपरा विद्या है और उससे आगे जो आत्मा का बोध और अनुभव है, वह परा विद्या है, इस प्रकार उपनिशद् ने भौतिकवाद के लिए 'अविद्या' षब्द का प्रयोग किया है और अध्यात्मवाद के लिए विद्या का। समस्त भौतिक विद्या अविद्या है। जिन्हें हम विद्यालय कहते हैं। वास्तव में वे अविद्यालय हैं, हम साइंस को भौतिक सुखों के उपकरणों को जुटाने वाले कल कारखानों और फैक्ट्रियों को और उनसे उपलब्ध होने वाली भौतिक सामग्री और भौतिक ऐष्यर्यों को विद्या कहते हैं, उपनिशदों की दृष्टि में वे सब अविद्या होते हुए भी विद्या जैसे प्रतीत होते हैं। वस्तुतः वे जीवन चलाने के उपकरण मात्र हैं। संक्षेप में विज्ञान ने प्रकृति को मनुष्य के लिए अत्यन्त सुन्दर और सुखद बना दिया है। परन्तु सब कुछ पाकर भी वह सुखी नहीं है और वह आज नारद के स्वर में मिलाकर कहने को विवष है – भगवन्। सब कुछ जान कर भी मैं भीतर ही भीतर खोखला सा अनुभव करता हूँ। सब कुछ पाकर भी मैं दुःखी हूँ। कारण ? स्वयं नारद के षब्दों में आज का मनुष्य 'मन्त्रवित्' तो है किन्तु 'आत्मवित्' नहीं। नारद की तरह उसके पास अपरा विद्या से प्राप्त भौतिक ज्ञान तो है, परन्तु परा विद्या से प्राप्य ब्रह्मज्ञान से वह सर्वथा षून्य है। षास्त्रों का ज्ञान-विज्ञान मनुष्य को नाममात्र का बोध कराता है, संसार के जंजाल से उसे ऊपर नहीं उठाता। संसार के जंजाल से उठकर अमृतत्व की प्राप्ति के लिए मनुष्य को आत्मज्ञान की आवष्यकता है उपनिशत् का कहना है कि भौतिक ज्ञान विद्या नहीं, अविद्या है, प्रकृति सुख का साधन अवष्य है, किन्तु वह सुखस्वरूप नहीं है। यथार्थ ज्ञान वह है जिसमें भौतिक एवम् आध्यात्मिक विद्या का सम्मिश्रण हो। इसलिए औपनिशदिक दृष्टिकोण से भौतिक तथा आध्यात्मिक दोनों प्रकार के ज्ञान को आत्मसात् करने से ही जीवन का समग्ररूप सामने आता है।

<sup>॥६॥</sup> कठ०/२/४

<sup>॥७॥</sup> कठ० २/१५

<sup>॥८॥</sup> छा० ७/१

<sup>॥९॥</sup> छा० ७/२

<sup>॥१०॥</sup> छा० ७/३, ४

<sup>॥११॥</sup> छा० ७/५

<sup>॥१२॥</sup> छा० ७/६

## A Study of Liouville's Theorem and Its Implications in Integration Theory

Manoj Kumar\*

### Abstract

Integration is considered as an important branch of mathematics. Numerical integration is known as to compute the definite integral value from a range of integrand numerical values. As compared to numerical differentiation, in numerical integration while calculating the value of the definite integral  $\int_b^a f(x)dx$ , an interpolation formula having differences takes place of the function  $f(x)$ . After that, this formula with a limit range from  $a$  to  $b$  is integrated.

**Keywords:** Integration, Integrand, Function

### Introduction

This theorem requires the initial data to have only one bounded derivative and provides the same regularity for the resulting solution.

We then proceed, where we show how to make the adjustments required in order to adapt our dispersion-velocity method to nonlinear problems. Following the discussion above, the derivation of our method is done on compacton-type equations, which develop structures with non-smooth interfaces.

Our numerical method is summarized in §4. For completeness we discuss several issues relating to various aspects of the implementation of the method, such as, e.g., the initialization, the cutoff functions and the accuracy of the method.

We conclude with several numerical examples, for linear and nonlinear equations. In the linear examples we are able to verify the accuracy and the  $L^2$  conservation properties of the scheme. In the nonlinear examples, it is remarkable to see how the particles that are spread over two compactons (moving with different velocities) are capable of going through the nonlinear compacton-compacton interaction and emerging from the interaction, while preserving the phase shift which is typical with this type of interaction.

Let  $f(x_k) = y_k$  be the nodal value at the tabular point  $x_k$  for  $k = 0, 1, \dots, n$  where  $x_0 = a$  and  $x_n = x_0 + nh = b$ . Integrand is replaced so as to get general quadrature formula.

$$\int_a^b f(x)dx = \int_a^b \left[ y_0 + \frac{\Delta y_0}{h}(x - x_0) + \frac{\Delta^2 y_0}{2!h^2}(x - x_0)(x - x_1) + \frac{\Delta^3 y_0}{3!h^3}(x - x_0)(x - x_1)(x - x_2) + \frac{\Delta^4 y_0}{4!h^4}(x - x_0)(x - x_1)(x - x_2)(x - x_3) + \dots \right] dx$$

Using the transformation  $x = x_0 + h$  yields:

\* Assistant professor in mathematics, R K S D COLLEGE, KAITHAL

$$\int_a^b f(x)dx = h \int_0^n \left[ y_0 + u\Delta y_0 + \frac{\Delta^2 y_0}{2!} u(u-1) + \frac{\Delta^3 y_0}{3!} u(u-1)(u-2) + \frac{\Delta^4 y_0}{4!} u(u-1)(u-2)(u-3) + \dots \right] du$$

Then,

$$\int_a^b f(x)dx = h \left[ ny_0 + \frac{n^2}{2} \Delta y_0 + \frac{\Delta^2 y_0}{2!} \left( \frac{n^3}{3} - \frac{n^2}{2} \right) + \frac{\Delta^3 y_0}{3!} \left( \frac{n^4}{4} - n^3 + n^2 \right) + \frac{\Delta^4 y_0}{4!} \left( \frac{n^5}{5} - \frac{3n^4}{2} + \frac{11n^3}{3} - 3n^2 \right) + \dots \right]$$

For n =1, we have

$$\int_a^b f(x)dx = h \left[ y_0 + \frac{\Delta y_0}{2} \right] = \frac{h}{2} [y_0 + y_1].$$

For n=2, we get

$$\begin{aligned} \int_a^b f(x)dx &= h \left[ 2y_0 + 2\Delta y_0 + \left( \frac{8}{3} - \frac{4}{2} \right) \frac{\Delta^2 y_0}{2} \right] \\ &= 2h \left[ y_0 + (y_1 - y_0) + \frac{1}{3} \times \frac{y_2 - 2y_1 + y_0}{2} \right] = \frac{h}{3} [y_0 + 4y_1 + y_2]. \end{aligned}$$

Here, an interpolating polynomial is used in place of the integrand over the whole interval [a,b] and integrated with the given range of limit. In general, formulae for numerical integration are obtained by dividing the interval [a,b] in n sub-intervals  $[x_k, x_{k+1}]$ , where,  $x_k = x_0 + kh$  for  $k=0,1,\dots,n$  with  $x_0 = a, x_n = x_0 + nh = b$ .

There is a common class of integration techniques which is known as interpolatory quadrature where the value of integration of f (interpolant) is evaluated that is supposed to be the closest to the real integral.

Here, a function g is known as interpolating function of f if satisfied:

$$g(x_i) = f(x_i) \quad \text{where, } i= 1,2,3,\dots,n$$

and

$$(x_i, f(x_i)) \quad \text{where, } i= 1,2,3,\dots,n.$$



It is observed that there are basically 3 steps of a quadrature scheme. First,  $f$  (integrand) is evaluated within a given range of limit. After that, a function is obtained which is helpful in interpolating  $f$ .

Generally, interpolant and integrand ( $f$ ) both are independent of each other as there is no need of the integrand  $f$ , while evaluating the interpolant.

### LIOUVILLIE'S THEOREM IN INTEGRATION

The theorem can also be used to deduce that the domain of a non-constant elliptic function  $f$  cannot be  $\mathbb{C}$ . Suppose it was. Then, if  $a$  and  $b$  are two periods of  $f$  such that  $\frac{a}{b}$  is not real, consider the parallelogram  $P$  whose vertices are  $0, a, b$  and  $a + b$ . Then the image of  $f$  is equal to  $f(P)$ . Since  $f$  is continuous and  $P$  is compact,  $f(P)$  is also compact and, therefore, it is bounded. So,  $f$  is constant.

The fact that the domain of a non-constant elliptic function  $f$  can not be  $\mathbb{C}$  is what Liouville actually proved, in 1847, using the theory of elliptic functions. In fact, it was Cauchy who proved Liouville's theorem.

If  $f$  is a non-constant entire function, then its image is dense in  $\mathbb{C}$ . This might seem to be a much stronger result than Liouville's theorem, but it is actually an easy corollary. If the image of  $f$  is not dense, then there is a complex number  $w$  and a real number  $r > 0$  such that the open disk centered at  $w$  with radius  $r$  has no element of the image of  $f$ . Define  $g(z) = 1/(f(z) - w)$ . Then  $g$  is a bounded entire function, since

$$(\forall z \in \mathbb{C}) : |g(z)| = \frac{1}{|f(z) - w|} < \frac{1}{r}.$$

So,  $g$  is constant, and therefore  $f$  is constant.

Any holomorphic function on a compact Riemann surface is necessarily constant.

Let  $f(Z)$  be holomorphic on a compact Riemann surface  $M$ . By compactness, there is a point  $p_0$  where  $|f(p)|$  attains its maximum. Then we can find a chart from a neighborhood of  $P_0$  to the unit disk  $D$  such that function is holomorphic on the unit disk and has a maximum at  $p_0$ , so it is constant, by the maximum modulus principle.

Let  $\mathbb{C} \cup \{\infty\}$  be the one point compactification of the complex plane  $\mathbb{C}$ . In place of holomorphic functions defined on regions in  $\mathbb{C}$ , one can consider regions in  $\mathbb{C} \cup \{\infty\}$ . Viewed this way, the only possible singularity for entire functions, defined on  $\mathbb{C} \subset \mathbb{C} \cup \{\infty\}$ , is the point  $\infty$ . If an entire function  $f$  is bounded in a neighborhood of  $\infty$ , then  $\infty$  is a removable singularity of  $f$ , i.e.  $f$  cannot blow up or behave erratically at  $\infty$ . In light of the power series expansion, it is not surprising that Liouville's theorem holds.

Similarly, if an entire function has a pole at  $\infty$ , i.e. blows up like  $z^n$  in some neighborhood of  $\infty$ , then  $f$  is a polynomial. This extended version of Liouville's theorem can be more precisely stated: if  $|f(z)| \leq M \cdot |z|^n$  for  $|z|$  sufficiently large, then  $f$  is a polynomial of degree at most  $n$ . This can be proved as follows. Again take the Taylor series representation of  $f$ ,

$$f(z) = \sum_{k=0}^{\infty} a_k z^k.$$

The argument used during the proof using Cauchy estimates shows that

$$(\forall k \in \mathbb{N}) : |a_k| \leq M r^{n-k}.$$

So, if  $k > n$ ,

$$|a_k| \leq \lim_{r \rightarrow +\infty} Mr^{n-k} = 0.$$

Therefore,  $a_k = 0$ .

Liouville's theorem does not extend to the generalizations of complex numbers known as double numbers and dual numbers.

Superficially, this definition is formally analogous to that of the derivative of a real function. However, complex derivatives and differentiable functions behave in significantly different ways compared to their real counterparts. In particular, for this limit to exist, the value of the difference quotient must approach the same complex number, regardless of the manner in which we approach in the complex plane. Consequently, complex differentiability has much stronger implications than real differentiability. For instance, holomorphic functions are infinitely differentiable, whereas the existence of the  $n$ th derivative need not imply the existence of the  $(n + 1)$ th derivative for real functions. Furthermore, all holomorphic functions satisfy the stronger condition of analyticity, meaning that the function is, at every point in its domain, locally given by a convergent power series. In essence, this means that functions holomorphic on can be approximated arbitrarily well by polynomials in some neighborhood of every point. This stands in sharp contrast to differentiable real functions; even infinitely differentiable real functions can be nowhere analytic.

### **Discussion**

Most elementary functions, including the exponential function, the trigonometric functions, and all polynomial functions, extended appropriately to complex arguments as functions, are holomorphic over the entire complex plane, making them entire functions, while rational functions, where  $p$  and  $q$  are polynomials, are holomorphic on domains that exclude points where  $q$  is zero. Such functions that are holomorphic everywhere except a set of isolated points are known as meromorphic functions.

An important property that characterizes holomorphic functions is the relationship between the partial derivatives of their real and imaginary components, known as the Cauchy-Riemann conditions. However, it is important to note that functions satisfying the Cauchy-Riemann conditions are not necessarily holomorphic, unless additional continuity conditions are met.

A bounded function that is holomorphic in the entire complex plane must be constant; this is Liouville's theorem. It can be used to provide a natural and short proof for the fundamental theorem of algebra which states that the field of complex numbers is algebraically closed.

If a function is holomorphic throughout a connected domain then its values are fully determined by its values on any smaller sub domain. The function on the larger domain is said to be analytically continued from its values on the smaller domain. This allows the extension of the definition of functions, such as the Riemann zeta function, which are initially defined in terms of infinite sums that converge only on limited domains to almost the entire complex plane. Sometimes, as in the case of the natural logarithm, it is impossible to analytically continue a holomorphic function to a non-simply connected domain in the complex plane but it is possible to extend it to a holomorphic function on a closely related surface known as a Riemann surface.

Along the numerical front, self-consistent solutions of the SPS equation are important in the simulations of a quantum system. For example, time-independent SP equation was solved in for the eigenstates of the quantum system, and time-dependent spherically symmetric SP equation was considered in and time- dependent SN equation was treated in with three kinds of symmetry: spherical, axial and translational symmetry.

For dynamics, a time-splitting pseudospectral discretization shows its accuracy and efficiency in practice. Such results suggest that we can extend these successful tools to the computation of ground states and dynamics of the SPS equation. For example, similar methods were extended in to treat a Gross-Pitaevskii-Poisson type system which is used to model dipolar BEC, and a time-splitting approach was used in for computing the dynamics of the SPS equation with periodic boundary conditions in all space dimensions. However, there still remains an issue that how to approximate the Hartree potential properly, which definitely affects the overall accuracy and efficiency.

In recent years great attention has been paid to some classes of systems of partial differential equations in which a Schrodinger equation is coupled to the Maxwell ones; the purpose is to describe the interaction of a nonlinear Schrodinger field with an electromagnetic field  $\mathbf{E} - \mathbf{H}$ .

As usual, for physical reasons, we look for solutions that have finite energy, i.e.  $(\mathbf{u}, \Phi) \in \mathbf{H}^1 \times \mathbf{D}^1$ , where  $\mathbf{H}^1 = \mathbf{H}^1(\mathbb{R}^3)$  is the usual Sobolev space endowed with the scalar product  $\langle \mathbf{u}, \mathbf{v} \rangle_{\mathbf{H}^1} := \int_{\mathbb{R}^3} (\mathbf{D}\mathbf{u} \cdot \mathbf{D}\mathbf{v} + \mathbf{u}\mathbf{v}) \mathbf{d}\mathbf{x}$  and norm  $\|\mathbf{u}\| = (\int |\mathbf{D}\mathbf{u}|^2 + \int \mathbf{u}^2)^{1/2}$ , and  $\mathbf{D}^1 = \mathbf{D}^1(\mathbb{R}^3)$  is the completion of  $\mathbf{C}_0^\infty(\mathbb{R}^3)$  with respect to the norm  $\|\mathbf{u}\|_{\mathbf{D}^1}^2 := \int_{\mathbb{R}^3} |\mathbf{D}\mathbf{u}|^2 \mathbf{d}\mathbf{x}$  induced by the scalar product  $\langle \mathbf{u}, \mathbf{v} \rangle_{\mathbf{D}^1} := \int \mathbf{D}\mathbf{u} \cdot \mathbf{D}\mathbf{v} \mathbf{d}\mathbf{x}$

Proposition" Assume that  $W$  satisfies  $W_1) - W_3)$ . Then for any  $\omega > 0$  there exist  $\lambda > 0$  and nontrivial radial functions  $(\mathbf{u}, \Phi) \in \mathbf{H}^1(\mathbb{R}^3) \times \mathbf{D}^1(\mathbb{R}^3)$  which solve the related system.

Analogously to the previous literature, in which  $\omega$  was found as a Lagrange multiplier, got by a minimization process on a suitable manifold, here we find the value of  $\lambda$  in this way. However, in our case the manifold is different from the usual one used in the studies cited above, which adopted similar procedures considering the unit sphere in  $L^2(\mathbb{R}^3)$ .

### Conclusion

Indeed, we introduce a new manifold which in the end turns out to be a good choice. on the other hand, our manifold is defined as  $\int \mathbf{u}^2 \Phi$  constant, so that no rearrangement approach can be done to prove radial decreasing properties of the solutions, where the equality  $\int |\mathbf{u}|^p = \int (\mathbf{u}^*)^p$  is fundamental.

The reattachment point of the isolating stream function curve is known as the length of the recirculation zone and the highest scale of the stream-function in the recirculation region is known as the strength of the circulation. The downstream and slanting co-ordinates of the point at which the highest magnitude of the stream-function is obtained.

Convenient local refinement can be obtained from the composite grid operator. The specification of the problem describes the selection of tiles to be refined and it is also decided that how much the tiles should be refined.

## References

1. Benjamin Fine; Gerhard Rosenberger (2010). The Fundamental Theorem of Algebra. Springer Science & Business Media. pp. 70–71. ISBN 978-0-387-94657-3.
2. Liouville, Joseph (2011), "Leçons sur les fonctions doublement périodiques", Journal für die Reine und Angewandte Mathematik (published 2011), **88**, pp. 277–310, ISSN 0075-4102
3. Cauchy, Augustin-Louis (2012), "Mémoires sur les fonctions complémentaires", Œuvres complètes d'Augustin Cauchy, 1, **8**, Paris: Gauthiers-Villars (published 2012)
4. Lützen, Jesper (2010), Joseph Liouville: Master of Pure and Applied Mathematics, Studies in the History of Mathematics and Physical Sciences, **15**, Springer-Verlag, ISBN 3-540-97180-7
5. A concise course in complex analysis and Riemann surfaces, Wilhelm Schlag, corollary 4.8, p.77 <http://www.math.uchicago.edu/~schlag/bookweb.pdf>
6. <https://www.rosehulman.edu/mathjournal/archives/2011/vol12-n2/paper4/v12n2-4pd.pdf>

## **Application Of Graph Theory Concepts In Cloud Computing**

**Shalu saini\***

### **Abstract**

Cloud Computing is a worldview of extensive scale Distributed Computing, which is a repackaging of different existing ideas/technologies, for example, Utility Computing, Grid Computing, Autonomic Computing, Virtualization and Internet technologies. Cloud Computing utilizes the Internet technologies to convey the assets as a service to clients on demand. The Cloud Service Providers (CSP) arrangement services through Cloud Data Center (CDC). The virtualized service provisioning conveys huge changes to IT business, which builds business incomes and in the meantime practical from the end client perspective. With every one of the points of interest, still the quantity of clients utilizing the open Cloud is 41% out of 80% Internet clients. The central point, which keep the clients from moving to the Cloud are cost and access time. What's more, from the CSP perspective, observing, booking, vitality proficiency, grouping CDCs, distribution of CDC and burden adjusting should be tweaked amid asset provisioning from Cloud so as to improve the entrance time and cost. Every one of these issues are gathered as asset provisioning issues in Cloud and are tended to utilizing Graph hypothetical systems to improve the service conveyance execution of CDC, which thus enhance the expense and access time.

**Keywords-** *Cloud Computing, Distributed Computing, Utility Computing, Grid Computing, Autonomic Computing, Virtualization and Internet technologies.*

### **1. Introduction**

In this world, the main thing that is consistent is change. The result of each change is called advancement. Be that as it may, in these thousands of advancements, a portion of the improvements have the ability to change the world totally. One of the striking advancements is the creation of PCs. From the day of its innovation, the advancement of PCs and computing innovation are on the vertical plane. One of the most recent improvements in the contemporary time of computing is Cloud Computing.

### **2. Literature Survey**

Ethan Galstad [6] managed Pull strategy for checking in Cloud condition. A Nagios Remote Plugin Executor (NRPE) was planned, which enabled clients to remotely execute Nagios modules on Linux/Unix machines. The observing machine pulled the remote machine measurements, for example, CPU load, plate utilization and RAM use. Windows specialist additional items were included request to screen remote Windows machines. The investigation detailed that the execution of Nagios modules on remote machines through Secure Shell (SSH) forced a huge CPU overhead on both checking machine and remote machine and took high reaction time.

Dariusz Sosnowski et al. [4] utilized Pull technique for checking in Cloud data focus. In this examination, an open source checking programming Nagios was coordinated into VMware Cloud Computing framework to screen equipment, organize foundation, Hypervisor and Operating System layer. Nagios pulled the checked data from low

---

\* Rajiv Gandhi govt. College for Women, Bhiwani, Extension lecturer in computer science



dimension equipment (circle utilization, swap use) and system framework to the Central Monitor. It was seen that the overhead on checking machine and remote machine was expanded because of the Pull strategy for observing in Cloud data focus.

The examination on Hyperic HQ [10] considered Pull strategy for checking in Cloud. Hyperic HQ was an open source observing stage created by VMware Inc and had an incorporated engineering to screen the physical and virtual Cloud framework execution. As Hyperic HQ was created utilizing Java, it kept running on all sort of stages. Hyperic HQ found the neighborhood asset states and services by intermittent questioning of checking data utilizing Pull technique. The examination announced that however this stage bolstered versatility, the use of Pull technique expanded overhead on framework and system.

Shirlei et al. [15] examined the execution of private Cloud observing utilizing Push strategy. The primary open source instrument for Private Cloud Monitoring System (PCMONS) was structured and executed to be a secluded observing system. PCMONS bolstered both the operator based and focal checking plans. The PCMON modules running in the private Cloud bunches pushed the data gathered from the groups to the group data integrator and thus to a Central Monitor upon trigger conditions. It was seen that the system overhead was high because of low push recurrence.

Stuart Clayman et al. [17] managed Push technique for checking in Cloud. Another observing structure, Lattice was created to screen the Cloud use, the services at present running in Cloud and the adjustments in the Cloud assets. The Lattice observing system pushed just significant data valuable for checking to keep away from high measure of tests streaming over the system. The Lattice was executed in the RESERVOIR service Cloud to gather both framework and system data and pushed the gathered data to the Central Monitor (CM). It was accounted for that the system overhead was high because of low push recurrence and likewise disappointment of hubs were not recognized by Central Monitor because of Push strategy.

Ethan Galstad [7] built up a Push-based structure for checking Cloud. Nagios Service Check Adaptor (NSCA) was created to help offbeat push estimations and occasions from observed hubs to the focal server. It didn't receive any standard arrangement for observed data portrayal. NSCA permitted remote Nagios hubs and applications to push data about latent hubs and observed data to focal Nagios server for handling. In this investigation likewise, it was accounted for that the system overhead was high because of low recurrence of Push strategy.

JiSu Park et al. [11] considered the execution of observing utilizing Push technique in Cloud data focus. A Markov Chain based observing component was created to anticipate asset status so as to handle instability of cell phones in Mobile Cloud Computing. This forecast based data was utilized to improve unwavering quality of framework. Different asset state data, for example, CPU, memory, arrange bandwidth and area were pushed from cell phones, when the usage rate went above limit esteem. This usage rate set the appropriate time interim to push observing data. A Viterbi calculation was utilized to display Markov Chain to foresee issues dependent on the pushed data. It was reasoned that the system overhead was high because of low observing interim.

Xinkui Zhao et al. [19] managed Hybrid strategy for Cloud observing. To reproduce and assess Cloud observing systems, an instrument SimMon was created. The SimMon hybridized Push and Pull techniques. SimMon pushed checked data to specialists, when the asset use surpassed the predefined limit level. SimMon then pulled the put away data at



specialists to acquire checking data. In this examination, it was accounted for that low checking interim influenced the system execution.

He Huang et al. [9] defined a Hybrid technique for Cloud observing. The Pull and Push strategy for Grid checking were reached out to Cloud observing. The Push and Pull (PP) asset checking model consolidated the advantages of both the models and exchanged cleverly among Push and Pull demonstrate as per the asset status and client's prerequisites. In spite of the fact that PP show diminished the refreshing expense contrasted with Push and Pull models, still the system overhead was high because of low observing interim.

### **3. Cloud Computing**

"Cloud Computing is a model for empowering universal, helpful, on-demand arrange access to a mutual pool of configurable computing assets (e.g., systems, servers, stockpiling, applications, and services) that can be quickly provisioned and discharged with negligible administration effort or service provider interaction"(Peter Mell et al. [12]). The primary technology for its significant business reception is Virtualization (Pearce. M et al.[13]). Virtualization is utilized to make a virtual computing condition. It gathers every one of the assets and makes a solitary virtual condition. This gives abstract perspective on physical computing assets. A virtualized Cloud foundation, otherwise known as CDC has physical layer and abstraction layer (Caesar Wu and Rajkumar Buyya [3]). The CDC has a lot of interconnected Physical Machines(PM), which are implanted with the arrangement of Virtual Machines(VM). The physical layer has equipment segments (server, stockpiling and system part), which are provisioned to the clients as virtualized segments on demand. The abstraction layer gives abstract perspective on the physical layer and shrouds complex internal subtleties of the physical layer. By utilizing ideas from Service Oriented Architecture (SOA), which is an idea of giving services to the client, Cloud Computing arrangements its assets as services and it is named as Everything as a Service (XaaS) (Thomas Erl [18]) (Duan Yet al.[5]). From Utility Computing, Cloud receives pay-as-you-go idea, which is an idea of building up measurements for services.

#### **3.1 Characteristics Of Cloud Computing**

Cloud Computing varies from conventional computing by having the accompanying basic characteristics: (National Institute of Standards and Technology-NIST) (Peter Mell et al. [12])

- On-demand self-service: Cloud clients can get to assets without requiring any focal administrator mediation.
- Broad arrange get to: The gadgets, for example, thick, slight and portable customers can be utilized to get to Cloud assets.
- Resource pooling: Resources, for example, handling, memory, stockpiling and bandwidth are pooled to serve utilizing a multi-occupant model with area freedom.
- Rapid flexibility: Resources can be scaled up and downsized to fulfill the client needs and giving a deception that there is a boundless pool of assets.
- Measured service: Resource utilizations are checked, metered and announced, giving straightforwardness in bills.

#### **3.2 Service Delivery Models**

Cloud offers diverse sort of services to clients on pay-per-use mode, which are ordered as pursues and are shown in Figure 1.

- Software as a Service (SaaS): Consumers utilize the Cloud Computing provider's applications running on a Cloud framework from different customer gadgets.

- Platform as a Service (PaaS): Consumers can send client made applications into the Cloud foundation utilizing programming dialects and instruments bolstered by the provider. The clients can have power over the sent applications.
- Infrastructure as a Service (IaaS): Consumers are provisioned with handling, stockpiling and systems, where the purchaser can convey and run discretionary software, which can incorporate Operating Systems and applications. The shopper is free from dealing with the basic Cloud framework.

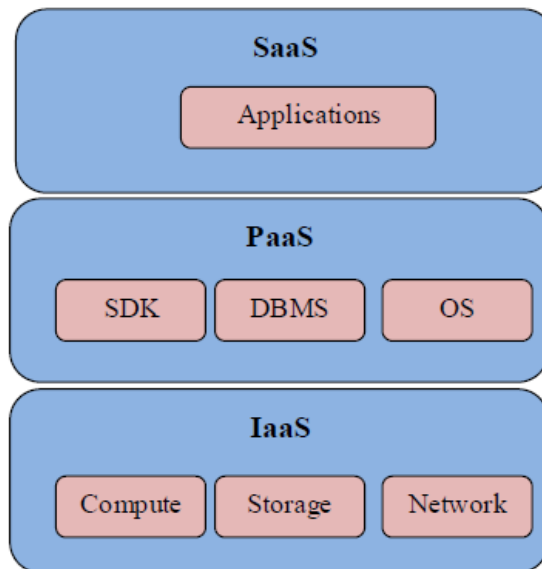

**Figure 1 Cloud Service Delivery Models**

### 3.3 Deployment Models

The kinds of Cloud condition dependent on the proprietorship and access strategy can be determined as pursues and are delineated in Figure 2.

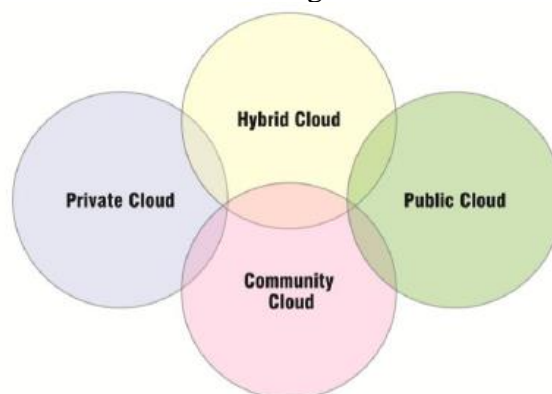

**Figure 2 Cloud Deployment Model**

- Public Cloud: The Cloud framework is claimed, overseen and worked by an outsider provider. Amazon and Google are a portion of the outsider Cloud Service Providers. The Information Technology (IT) assets are provisioned to the overall population at an expense.

- Private Cloud: The Cloud foundation is possessed, overseen and worked by a solitary association to store and process the association's data and give get to just to its representatives, which improves verified data get to.
- Community Cloud: It is like an open Cloud, yet with constrained access. The Cloud framework is provisioned to a particular network of clients from associations that have shared concerns (security, consistence and so on.)
- Hybrid Cloud: The Cloud framework is a structure of various Cloud foundations (private, network or open) mostly to help Cloud blasting. At the point when application running in a private Cloud demands for all the more computing limit, it can blast into open Cloud to satisfy the needs. Besides, in cross breed set up, touchy data can be kept at private Cloud, while less-delicate data can be moved to open Cloud so as to improve the data security.

#### **4. Graph Theory**

A theory winds up significant, when it has applications, all things considered. Utilization of mathematical model or procedure to model or speak to genuine issue is called mathematical modeling. Graph theory is one such model for speaking to true elements and procedures. A Graph is an abstract mathematical structure formed by a lot of vertices and edges joining sets of those vertices and used to model association among the articles. Taking care of a hidden issue with Graph theory to get an answer is proportionate to acquire an answer for the first certifiable issue.

Graph theory branches from discrete mathematics, which examines the properties and applications of graph (Bondy J.A. and Murty U.S.R. [1]). It models connections among the substances. One of the upsides of graph theory is to give a typical formalism to various issues. Then, it presents graph calculations for these issues. In every one of the areas, where graphs are utilized for modeling, the vertices or hubs model the items, while the edges model the relationship among the articles.

Graph theory was presented by Euler and was considered to have started in the year 1736 with the production of Euler's answer of the Konigsberg connect issue (Caccetta L [2]). In any case, the previous 30 years have been an exceptional research time of unadulterated and connected graph theory. The exploration on software engineering amid the late 20th century has prompted the advancement of graph theory into handy applications. It winds up huge in the field of software engineering due its immense applications in this field. Any down to earth issue can be spoken to utilizing some graph structure in PC and calculations can be utilized for handling such graph structures to give better arrangements.

Different issues in graph theory, for example, Euler circuits, Hamiltonian circuits, four shading issue, planarity of graphs and Kurtowski's graphs had been all around inquired about and had discovered applications in various areas (Gary Chartrand et al. [8]).

To have a legitimate understanding of graph theory, it is critical to be acquainted with the fundamental wordings in graph, particularly the phrasings utilized in this thesis. A Graph is an arranged pair  $G = (V, E)$  including a set  $V$  of vertices together with a set  $E$  of edges interfacing the vertices in  $V$ . In Figure 3, the arrangement of vertices  $V = \{1,2,3,4,5\}$  and the arrangement of edges are  $\{(1,2),(1,3),(1,4),(2,5),(3,4),(4,5)\}$ .

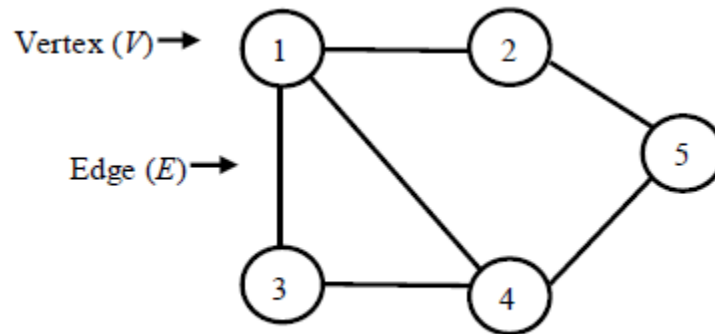

**Figure 3 Graph**

In light of the course on the edges, the graphs can be delegated coordinated and undirected graphs. An Undirected Graph has no heading anxious between hubs. Figure 4 is an undirected graph as edges have no course. The edges can be navigated in either bearings. For instance, the edge (1, 2) is same as (2, 1). Formally:  $\forall u,v \in E, (u,v)=(v,u)$  and  $u \neq v$ . A Graph is called weighted, when it has weight (a numerical esteem) on the edges. Weight commonly demonstrates the expense of navigating or separations among vertices and it relies upon the application in which it is utilized. Figure 5 demonstrates a weighted graph with loads on edges between vertices.

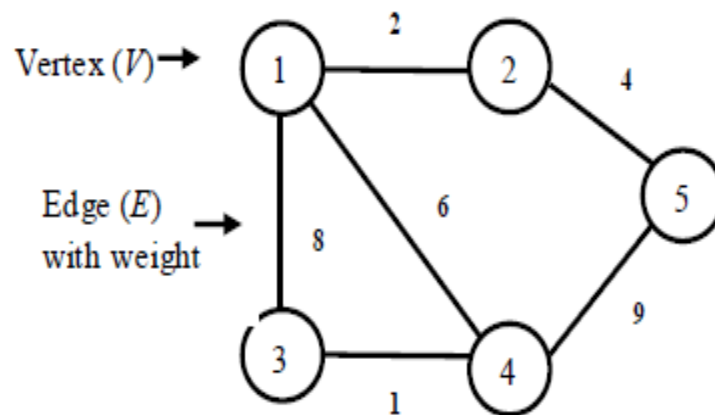

**Figure 4 Weighted Graph**

A Graph is said to be associated graph, if each pair of vertices has a way between them. In Figure 4, there is a way between each pair of vertices and is an associated graph. A Graph is said to be a tree, on the off chance that it is an associated graph without any cycles. Figure 5 signifies a tree.

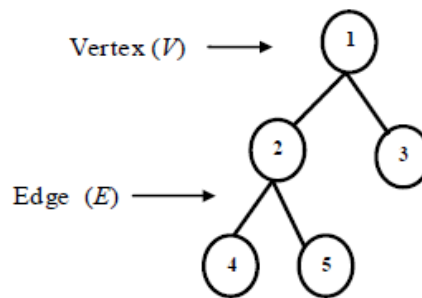

**Figure 5 Tree**

A way in a graph is an arrangement of vertices, in which each pair of progressive vertices is associated by an edge. The length of the way is the quantity of edges in that way. In Figure 6 the grouping of vertices (1, 2, 4) characterizes a way. The level of a vertex in the graph is the quantity of edges at that hub. In the Figure 1.6, the level of vertex 1 is 3. A mathematical representation can be given to a graph as far as an adjacency matrix. An adjacency matrix is a two dimensional cluster, where every cell of the matrix speaks to whether there is a way between two vertices. Cells contain '1' when there is an edge between two vertices and '0' when there is no edge between two vertices. Corner to corner passages contain '0', when self edges are not permitted. Figure 6 demonstrates the adjacency matrix for the graph in Figure 4.

Vertex ID	1	2	3	4	5
1	0	1	1	1	0
2	1	0	0	0	1
3	1	0	0	1	0
4	1	0	1	0	1
5	0	1	0	1	0

← Matrix cell

**Figure 6 Adjacency Matrix for the Graph**

#### 4.1 Applications Of Graph Theory

Graph theory has been discovered substantial number of applications in software engineering space. This segment records a portion of the applications of graph theoretical ideas in different fields of software engineering. The improvement of calculations to handle graphs is therefore of real enthusiasm for software engineering. Calculations for discovering graph characteristics, most brief way/removes in the graphs, crossing trees of a graph, verbalization focuses, pursuit of specific hubs have been widely sought after and numerous variations are accessible. The wide extent of graph theory applications has been all around archived in Bondy J.A. and Murty U.S.R. [1], Shirinivas S.G. et al.[6], Caccetta L et al.[2] and Roberts F.S [14].

Table 1 presents outline of the graph theory applications in different sorts of systems and applications. Since CDC is a system structure, these graph theoretical methods can be broke down for their appropriateness to Cloud asset provisioning issues.

**Table 1 Graph Theory Applications in Computer Networks**

Graph theory technique	Applications	Type of networks
Graph coloring	<ul style="list-style-type: none"> <li>Interference reduction</li> <li>Interference Aware TDMA Link scheduling</li> <li>Job scheduling/Assignment problems</li> <li>Resource allocation</li> </ul>	Wireless networks- Mobile Adhoc Networks and Sensor networks
Dominating set and Connected Dominating Set	<ul style="list-style-type: none"> <li>Routing</li> <li>Fault tolerance</li> <li>Energy-efficiency</li> <li>Delivery delay reduction</li> <li>Connectedness</li> <li>Virtual backbone construction for efficient routing</li> <li>Overlay network construction</li> <li>Search space reduction</li> <li>Clustering nodes</li> </ul>	
Random Graphs	<ul style="list-style-type: none"> <li>Connectivity</li> <li>Scalability</li> <li>Routing</li> <li>Congestion handling</li> <li>Modeling the network</li> </ul>	
Shortest path algorithms	<ul style="list-style-type: none"> <li>Route computation for communication</li> </ul>	
Spanner	<ul style="list-style-type: none"> <li>Minimum power assignment</li> </ul>	
Topological graph	<ul style="list-style-type: none"> <li>Network Coverage problem</li> </ul>	
Graph embedding	<ul style="list-style-type: none"> <li>Routing</li> </ul>	
Graph labeling	<ul style="list-style-type: none"> <li>Fast communication via radio labeling</li> </ul>	Mesh network
Gabriel graph, Unit graph	<ul style="list-style-type: none"> <li>Routing with guaranteed delivery</li> </ul>	
DAG	<ul style="list-style-type: none"> <li>Workflow modeling</li> <li>Loop-free routing</li> <li>Task scheduling</li> </ul>	
Network flow	<ul style="list-style-type: none"> <li>Flow optimization</li> </ul>	Datacenter
Tree	<ul style="list-style-type: none"> <li>Data center/ network modeling</li> </ul>	General network
Graph matching	<ul style="list-style-type: none"> <li>Abnormal event detection in network by graph comparison</li> </ul>	
Spanning and Minimum Spanning tree algorithms	<ul style="list-style-type: none"> <li>Loop-free Connectedness</li> <li>Clustering</li> </ul>	
Graph traversal	<ul style="list-style-type: none"> <li>Searching an object</li> </ul>	General network query optimization
Graph partitioning	<ul style="list-style-type: none"> <li>Clustering</li> <li>Faster communication</li> </ul>	Real road networks, World Wide Web
Virtualized graph model	<ul style="list-style-type: none"> <li>Grid service reliability evaluation</li> </ul>	Grid
Set Covering Problem	<ul style="list-style-type: none"> <li>Mapping applications with data sets</li> </ul>	
Cayley digraphs	<ul style="list-style-type: none"> <li>Design of scalable Interconnection networks</li> </ul>	Database
KD-Tree	<ul style="list-style-type: none"> <li>Multi-dimensional Search</li> </ul>	
detaticapaC des gnitanimot	<ul style="list-style-type: none"> <li>Minimum capacitated dominating set construction</li> </ul>	skrowten sseleriW
Facility location problem	<ul style="list-style-type: none"> <li>Locating centers</li> </ul>	ytilicaf lareneG

### 5. Experimentation Setup

A reenactment think about was directed in CloudSim3.0.3 test system to consider the performance of the proposed algorithms. The Table 1 demonstrates the recreation settings for status monitoring and scheduling. Data focus was made first with details that characterize the engineering, Operating System, Hypervisor or Virtual Machine Manager (VMM) and it was set up to have X86 design, Linux working framework running Xen VMM. The Xen hypervisor was utilized to virtualize CDC assets. The general design of the data focus was kept normal for both the monitoring and scheduling tests. Next, the arrangement of Physical Machines (PM) was set up. The quantity of PMs was fluctuated



from 100 to 500 to check the versatility of algorithms. The CPU of PM was given a characterized handling power, estimated in Millions of Instructions Per Second (MIPS) and was set to changing MIPS and RAM (memory) was likewise set to have fluctuating qualities so as to produce heterogeneous PMs. The capacity and bandwidth on system joins were set to 1 TB and 1 Gbps individually. Next, the characteristics of VMs were characterized by parameters, for example, handling power in MIPS, RAM in Mega Bytes (MB) and bandwidth in Megabits every second (Mbps). The quantity of VMs was shifted from 100 to 500 to check the adaptability of algorithms. The quantity of Processing Elements (PE), which are known as centers or CPUs of the VMs was set to 2. The MIPS and RAM were set to have fluctuating qualities so as to produce VMs with differing demands and bandwidth was set to have 1000 Mbps. The last setup settings in this procedure was the age of employments/undertakings (for example cloudlets). The quantity of cloudlets was shifted from 100 to 500. The cloudlets were characterized dependent on particulars that characterize the errand length in a huge number of directions (MI) and was to set to have changing qualities so as to produce assignments of various sizes. The information and yield record estimate before and after execution of cloudlets were set to 300 MB.

**Table 2 Simulation Settings**

Parameter	Value
<b>Configuration of Data center</b>	
Data center architecture	X86
Data center OS	Linux
VMM	Xen
<b>Configuration of PMs</b>	
No of PMs	100-500
MIPS	Varying
RAM	Varying
Storage	1 TB
Bandwidth	1 Gbps

### 5.1 Monitoring

An associated heterogeneous CDC was set up by having heterogeneous setups for PMs and VMs. As CDC was a thick structure, the CDC graph was spoken to as an adjacency matrix. Presently, MDS was kept running on graph of changing sizes going from 100 to 500 hubs to create diverse MDS hubs. 25 keeps running of V-MDS was completed. The MDS hubs gathered burden status from their neighbors and pushed the information to handle at regular intervals. The quantity of message updates and update time were considered as assessment measurements to contrast and Pull and Push methods. In the most dire outcome imaginable, the quantity of messages traded by Pull technique was  $2n$ , where  $n$  number of solicitation messages and  $n$  number of answer messages traded among agent and PMs. On the off chance that the monitoring recurrence was  $m$ , then the general number of messages traded between the specialist and the PMs would be limited by  $2mn$ . The lesser the quantity of message updates, the lesser the system overhead, henceforth, in this test, an

endeavor was made to think about the quantity of messages updates by the MDS technique. To assess the performance of MDS technique, it was contrasted and Pull and Push strategy. Figure 7 demonstrates the quantity of messages updates utilizing MDS, Pull and Push methods. The quantity of message updates shifted from 0-1000 as for the quantity of PMs. On expanding the quantity of PMs in the augmentation of 100, it was seen that the MDS produced under 200 number of message updates, though the Pull technique created upto 1000 message updates and Push strategy produced 320 message updates for 500 PMs. It was obvious from the outcome that, MDS produced lesser number of message updates than Pull and Push methods. MDS outperformed Pull and Push methods, as the quantity of message updates was legitimately relative to the extent of MDS. In Pull strategy, the quantity of message updates was straightforwardly corresponding to double the quantity of hubs.

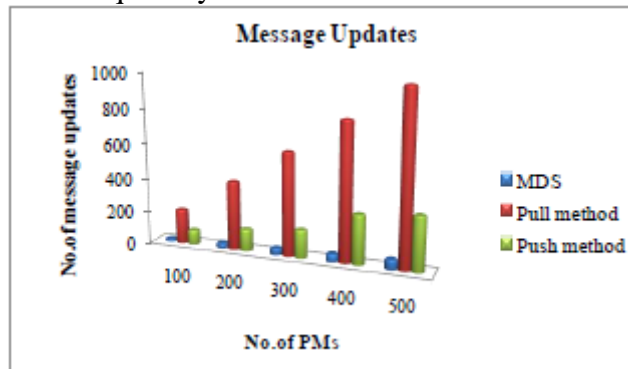

Figure 7 MDS vs. Pull and Push Methods for Message Updates

The lesser the update time, the productive is the monitoring procedure. Figure 8 demonstrates the normal update time utilizing MDS, Pull and Push methods. The normal update time changed from 0 to 5 seconds regarding the quantity of PMs. On expanding the quantity of PMs in the addition of 100, it was seen that the Pull technique took 4.5 seconds, Push strategy took 2.9 seconds and the MDS took limit of 2 seconds for 500 PMs setup. From the outcome, obviously the normal update time of MDS was lesser than Pull and Push methods. In MDS, the update time was less as it questioned just MDS hubs, though the Pull technique questioned every one of the hubs and Push strategy pushed data from the greater part of its hubs.

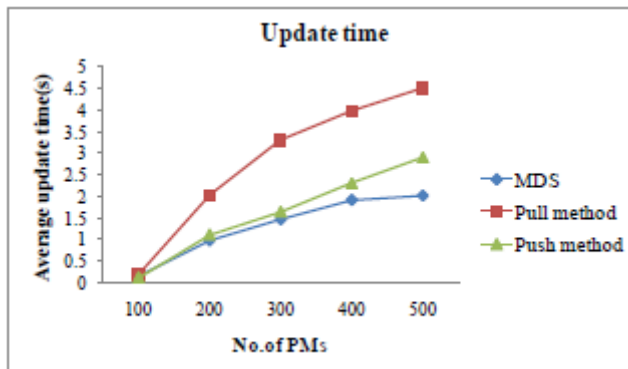

Figure 8 MDS vs. Pull and Push Methods for Update Time

## 5.2 Scheduling

In the heterogeneous CDC set up, the expense of VMs was fluctuated relying upon its arrangement. Dynamic remaining task at hand in CDC was created by shifting the quantity

of Cloudlets from 100 to 500 and its length. The accessibility status acquired from stage I was utilized for scheduling the assignments in this stage. The specialist summoned the scheduling algorithm to plan the assignments to cost-effective VM. The proposed cost-effective Dynamic Batch Mode algorithm was contrasted and three other prevalent and standard group mode scheduling plans to be specific, Round Robin, Min-Min and Max-Min to assess performance. The expense and VM usage were considered as measurements for assessing the algorithms.

## **6. Conclusion**

Graph-Based Modeling, Monitoring and Dynamic Batch Mode Cost-Efficient Independent Task Scheduling Scheme in Cloud Computing - The lesser the quantity of updates, the lesser the system overhead, consequently, the examination on number of message updates on MDS algorithm is directed. The outcomes obviously uncovers that MDS creates under 200 number of message updates, though Pull strategy produces 1000 message updates and Push technique produces 320 message updates for a similar 500 PMs. In MDS, the quantity of message updates is straightforwardly relative to the extent of MDS; subsequently it creates lesser number of message updates. Therefore, MDS algorithm is found to work productively with less number of updates.

The lesser the update time, the more the proficiency of monitoring process, therefore, the investigation is led to inspect the normal update time of the MDS algorithms. The outcome demonstrates that MDS took least of 2 seconds for 500 PMs, though Pull technique took 4.5 seconds and Push strategy took 2.9 seconds for a similar number of PMs. In MDS, the update time is less as it questions just MDS hubs. Subsequently, it is obvious that MDS set aside lesser effort for effective monitoring of CDC.

The lesser the VM cost, the lesser the cost of Cloud clients, thus, an examination is done on expense acquired for assignment execution by the proposed algorithm. The last outcome demonstrates that Dynamic Batch Mode algorithm causes less cost 1480 INR for executing 500 Cloudlets, though Round Robin, Min-Min and Max-Min algorithms took 3525 INR, 5000 INR, 5000 INR individually. The Dynamic Batch Mode algorithm plans Cloudlets to least-cost VMs, thereby decreasing by and large expense of executing Cloudlets. Consequently, clearly the Dynamic Batch Mode algorithm is the most cost-productive in executing Cloudlets.

The lesser the quantity of VMs used, the lesser the vitality utilization in CDC, subsequently, an examination is led to locate the normal number of VMs used for undertaking execution by the proposed algorithms. The Dynamic Batch Mode algorithm uses less number of VMs for executing Cloudlets than other algorithms. The final product plainly demonstrates that Dynamic Batch Mode algorithm limits the normal VM usage than other algorithms.

## **References**

- [1] Bondy J A and Murty U S R. Graph theory with applications, Elsevier science publishing, 1976.
- [2] Caccetta L. and Vijayan K, Applications of graph theory, Fourteenth Australasian Conference on Combinatorial Mathematics and Computing, Ars Combinatoria, Vol. 23, 1987, 21-77.
- [3] Caesar Wu and Rajkumar Buyya, Cloud Data Centers and Cost Modeling : A Complete Guide To Planning, Designing and Building a Cloud Data Center, 1st Morgan Kaufmann Publishers Inc. San Francisco, CA, USA, 2015.

- [4] Dariusz Sosnowski, Krzysztof Bielawski, Monitoring VMware-Based Cloud Computing infrastructure with Nagios, *Advances in Computer Science Research*, 12 (2015), 79-93.
- [5] Duan Y., Fu G., Zhou N., Sun X., Narendra N. C., and Hu, B., Everything as a Service (XaaS) on the cloud: origins, current and future Trends, *Proceedings of the CLOUD '15 2015 IEEE 8th International Conference on Cloud Computing*, IEEE, (2015), 621-628.
- [6] Ethan Galstad, Nagios NRPE Documentation, [Online], <http://nagios.sourceforge.net/docs/nrpe/NRPE.pdf>, (2017).
- [7] Ethan Galstad, NSCA-Nagios Service Check Acceptor, [Online], <https://assets.nagios.com/downloads/nagiosxi/docs/How-to-Use-the-NSCAAddon.pdf>, (2017).
- [8] Gary Chartrand, Ping Zhang, *A First Course in Graph Theory*, Dover books on mathematics, Courier Corporation, 2012.
- [9] He Huang., Liqiang Wang., P&P: a combined push-pull model for resource monitoring in cloud computing environment, *Proceedings of the 2010 IEEE 3rd International Conference on Cloud Computing (CLOUD)*, IEEE, (2010), 260–267.
- [10] Hyperic HQ, VmWare Inc, [Online]. <http://www.hyperic.com/>, (2012).
- [11] JiSu Park., HeonChang Yu., KwangSik Chung., and EunYoung Lee., Markov Chain Based Monitoring Service for Fault Tolerance in Mobile Cloud Computing, *2011 IEEE Workshops of International Conference on Advanced Information Networking and Applications (WAINA)*, (2011), 520–525.
- [12] Peter Mell, Timothy Grance, *The NIST Definition of Cloud Computing*, National Institute of Standards and Technology Special Publication, (2011), 800-145.
- [13] Pearce. M, Zeadally. S, and Hunt. R, Virtualization: Issues, security threats, and solutions, *ACM Computing Surveys*, 45 (2) (2013),1-39.
- [14] Roberts F.S., *Graph theory and its applications to the problems of society*, CBMSNSF Monograph 29, SIAM Publications, Philadelphia, 1978.
- [15] Shirlei Aparecida de Chaves, Rafael Brundo Uriarte, Carlos Becker Westphall, Toward an architecture for monitoring private clouds, *IEEE Communications Magazine*, 49(12) (2011), 130–137.
- [16] Shirinivas S.G., Vetrivel S., Elango N.M., Applications of graph theory in Computer Science: An overview, *International Journal of Engineering Science and Technology*, 2(9), 2010, 4610-4621.
- [17] Stuart Clayman., Alex Galis., Clovis Chapman., Giovanni Toffetti., Luis Roderomero., Luis M. Vaquero., Kenneth Nagin., and Benny Rochwerger., Monitoring service clouds in the future Internet, *Proceedings of the Towards the Future Internet*, IOS Press, (2010), 115–126.
- [18] Thomas Erl, *Service-Oriented Architecture: Concepts, Technology, and Design*, Prentice Hall PTR Upper Saddle River, NJ, USA, 2005.
- [19] Xinkui Zhao, Jianwei Yin, Chen Zhi and Zuoning Chen, SimMon: a toolkit for simulation of monitoring mechanisms in cloud computing environment, *Concurrency and Computation: Practice and Experience*, 29(1) (2016),1-25.

## **A Study of Serial Channel with Feedback, Balking and Reneging when Connected with Non-Serial Queuing Processes**

**Mr Vakil Kumar\***

### **1 Abstract**

Most of the studies in the theory of queues relate to Poisson arrivals and exponential holding times with ordered queue discipline. Jain (2000) studied a general model of long queues with reneging and balking phenomenon. Vikram and Singh (2002) obtained steady-state solution of serial queuing processes with reneging and balking.

This paper provides the steady-state solution of general queuing processes with feedback, balking and reneging connected with non-serial queuing channels in which

- (i) M serial queuing processes with feedback, balking and reneging connected with N non serial queuing channels.
- (ii) A customer may join any channel from outside and leave the system at any stage after getting service.
- (iii) Feedback is permitted from each channel to its previous channel in serial channels.
- (iv) The customer may balk due to long queue at each serial service channel.
- (v) The impatient customer leaves the service facility after wait of certain time.
- (vi) The input process in serial channels depends upon queue size and Poisson arrivals are followed.
- (vii) Exponential service times are followed.
- (viii) The queue discipline is random selection for service.

Two models A and B have been studied accordingly as the waiting space is infinite or finite. The expressions for marginal probabilities and mean queue length have been derived whenever the queue discipline is first come first served. The applications of such models are of common occurrence in administrative setup, multispecialty hospitals.

**Key Words :** Steady-State, difference-differential, feedback, reneging and balking.

### **2 Formulation of the Model**

---

\* Extension Lecturer in Mathematics, Govt. College, Assandh, Karnal

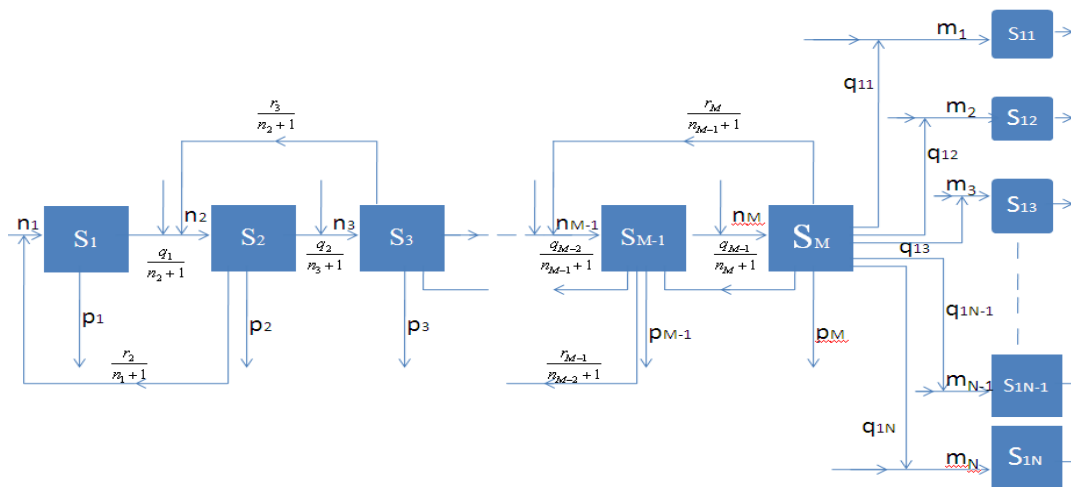

Fig. (2.1)

The system consists of the serial queues  $Q_j (j=1,2,3,\dots,M)$  and non-serial channels  $Q_i (i=1,2,3,\dots,N)$  with respective servers  $S_j (j=1,2,3,\dots,M)$  and  $S_{1i} (i=1,2,3,\dots,N)$ . Customers demanding different types of service arrive from outside the system in Poisson stream with parameters  $\lambda_j (j=1,2,3,\dots,M)$  and  $\lambda_{1i} (i=1,2,3,\dots,N)$  at  $Q_j (j=1,2,3,\dots,M)$  and  $Q_{1i} (i=1,2,3,\dots,N)$  but the sight of long queue at  $Q_j (j=1,2,3,\dots,M)$  may discourage the fresh customer from joining it and may decide not to enter the service channel at  $Q_j (j=1,2,3,\dots,M)$ . Then the Poisson input rate at  $Q_j (j=1,2,3,\dots,M)$  would be  $\frac{\lambda_j}{n_j + 1}$  where  $n_j$  is the queue size of  $Q_j (j=1,2,3,\dots,M)$ .

Further, the impatient customer joining any service channel  $Q_j (j=1,2,3,\dots,M)$  may leave the queue without getting service after wait of certain time. Here  $C_{in_i}$  is the renegeing rate at which customer renege after a wait of time  $T_{0i}$  whenever there are  $n_i$  customer in

the service channel  $Q_i$  where  $C_{in_i} = \frac{\mu_i e^{-\frac{\mu_i T_{0i}}{n_i}}}{1 - e^{-\frac{\mu_i T_{0i}}{n_i}}}$  ( $i=1,2,3,\dots,M$ ). Service time

distributions for servers  $S_j (j=1,2,3,\dots,M)$  and  $S_{1i} (i=1,2,3,\dots,N)$  are mutually independent negative exponential distribution with parameters  $\mu_j (j=1,2,\dots,M)$  and  $\mu_{1i} (i=1,2,3,\dots,N)$  respectively. After the completion of service at  $S_j$ , the customer either leaves the system with probability  $p_j$  or joins the next channel with probability  $\frac{q_j}{n_{j+1} + 1}$  or

join back the previous channel with probability  $\frac{r_j}{n_{j-1} + 1}$  such that  $p_j + \frac{q_j}{n_{j+1} + 1} + \frac{r_j}{n_{j-1} + 1} = 1$  ( $j=1,2,3,\dots,M-1$ ) and after the completion of service at  $S_M$  the customer either leaves



the system with probability  $p_M$  or join back the previous channel with probability  $\frac{r_M}{n_{M-1} + 1}$  or join any queue  $Q_i (i=1,2,3,\dots,N)$  with probability  $q_{Mi} (i=1,2,3,\dots,N)$  such that

$$p_M + \frac{r_M}{n_{M-1} + 1} + \sum_{i=1}^N q_{Mi} = 1. \text{ It is being mentioned here that } r_j = 0 \text{ for } j=1 \text{ as there is no}$$

previous channel of the first channel.

### 3 Formulation of Equations

Define:  $P(n_1, n_2, n_3, \dots, n_{M-1}, n_M, m_1, m_2, m_3, \dots, m_{N-1}, m_N; t)$  = the probability that at time 't' there are  $n_j$  customers (which may balk, renege or leave the system after being serviced or join the next phase or join back the previous channel) waiting before  $S_j (j=1,2,3,\dots,M-1, M)$ ;  $m_i$  customers (which may leave the system after being serviced) waiting before the servers  $S_{li} (i=1,2,3,\dots,N)$ .

We define the operators  $T_i, T_{i-1}, T_{i,i+1}, T_{i-1,i}$  to act upon the vectors  $\mathbf{n} = (n_1, n_2, n_3, \dots, n_M)$  or  $\mathbf{m} = (m_1, m_2, m_3, \dots, m_N)$  as follows

$$\begin{aligned} T_i(\mathbf{n}) &= (n_1, n_2, n_3, \dots, n_i - 1, \dots, n_M) \\ T_{i-1}(\mathbf{n}) &= (n_1, n_2, n_3, \dots, n_i + 1, \dots, n_M) \\ T_{i,i+1}(\mathbf{n}) &= (n_1, n_2, n_3, \dots, n_i + 1, n_{i+1} - 1, \dots, n_M) \\ T_{i-1,i}(\mathbf{n}) &= (n_1, n_2, n_3, \dots, n_{i-1} - 1, n_i + 1, \dots, n_M) \end{aligned}$$

Following the procedure given by Kelly, we write the difference-differential equations as

$$\begin{aligned} \frac{d P(\mathbf{n}, \mathbf{m}; t)}{dt} &= - \left[ \sum_{i=1}^M \frac{\lambda_i}{n_i + 1} + \sum_{i=1}^M \delta(n_i) (\mu_i + C_{i_i}) + \sum_{j=1}^N \lambda_j + \sum_{j=1}^N \delta(m_j) \mu_j \right] P(\mathbf{n}, \mathbf{m}; t) \\ &+ \sum_{i=1}^M \frac{\lambda_i}{n_i} P(T_i(\mathbf{n}), \mathbf{m}; t) + \sum_{i=1}^M (\mu_i p_i + C_{i_{i+1}}) P(T_{i-1}(\mathbf{n}), \mathbf{m}; t) \\ &+ \sum_{i=1}^{M-1} \mu_i \frac{q_i}{n_{i+1}} P(T_{i,i+1}(\mathbf{n}), \mathbf{m}; t) + \sum_{i=1}^M \mu_i \frac{r_i}{n_{i-1}} P(T_{i-1,i}(\mathbf{n}), \mathbf{m}; t). \\ &+ \sum_{j=1}^N \mu_j q_{Mj} P(n_1, n_2, \dots, n_M + 1, T_j(\mathbf{m}); t) \\ &+ \sum_{j=1}^N \lambda_j P(\mathbf{n} T_j(\mathbf{m}); t) + \sum_{j=1}^N \mu_j P(\mathbf{n} T_j(\mathbf{m}); t) \end{aligned} \tag{1}$$

for  $n_i \geq 0 (i=1,2,3,\dots,M)$ ,  $m_j \geq 0 (j=1,2,3,\dots,N)$ ;

where

$$\delta(x) = \begin{cases} 1 & \text{if } x \neq 0 \\ 0 & \text{if } x = 0 \end{cases}$$

and  $P(\mathbf{n}, \mathbf{m}; t) = 0$  if any of the arguments in negative.

### 4 Steady-State Equations

We write the following Steady-state equations of the queuing model by equating the time-derivate to zero in the equation (1)

$$\begin{aligned}
 & \left[ \sum_{i=1}^M \frac{\lambda_i}{n_i + 1} + \sum_{i=1}^M \delta(n_i)(\mu_i + C_{in_i}) + \sum_{j=1}^N \lambda_j + \sum_{j=1}^N \delta(m_j)\mu_j \right] P(\theta, \rho) \\
 &= \sum_{i=1}^M \frac{\lambda_i}{n_i} P(T_i, (\theta, \rho)) + \sum_{i=1}^M (\mu_i P_i + C_{in_i+1}) P(T_i, (\theta, \rho)) \\
 &+ \sum_{i=1}^{M-1} \mu_i \frac{q_i}{n_{i+1}} P(T_{i,i+1}, (\theta, \rho)) + \sum_{i=1}^M \mu_i \frac{r_i}{n_{i-1}} P(T_{i-1,i}, (\theta, \rho)) \\
 &+ \sum_{j=1}^N \mu_M q_{Mj} P(n_1, n_2, \dots, n_M + 1, T_j, (\theta, \rho)) + \sum_{j=1}^N \lambda_j P(\theta, T_j, (\theta, \rho)) + \sum_{j=1}^N \mu_j P(\theta, T_j, (\theta, \rho)) \quad (2)
 \end{aligned}$$

for  $n_i \geq 0$  ( $i = 1, 2, 3, \dots, M$ ),  $m_j \geq 0$  ( $j = 1, 2, 3, \dots, N$ );

### 5 Steady-State Solutions

The solutions of the Steady-State equations (2) can be verified to be

$$\begin{aligned}
 P(\theta, \rho) &= P(\theta, \theta) \left( \frac{1}{n_1!} \frac{\left( \lambda_1 + \frac{\mu_2 r_2 \rho_2}{(n_2 + 1)(\mu_2 + C_{2n_2+1})} \right)^{n_1}}{\prod_{i=1}^{n_1} (\mu_1 + C_{1i})} \right) \\
 &\cdot \left( \frac{1}{n_2!} \frac{\left( \lambda_2 + \frac{\mu_1 q_1 \rho_1}{(n_1 + 1)(\mu_1 + C_{1n_1+1})} + \frac{\mu_3 r_3 \rho_3}{(n_3 + 1)(\mu_3 + C_{3n_3+1})} \right)^{n_2}}{\prod_{i=1}^{n_2} (\mu_2 + C_{2i})} \right) \\
 &\cdot \left( \frac{1}{n_3!} \frac{\left( \lambda_3 + \frac{\mu_2 q_2 \rho_2}{(n_2 + 1)(\mu_2 + C_{2n_2+1})} + \frac{\mu_4 r_4 \rho_4}{(n_4 + 1)(\mu_4 + C_{4n_4+1})} \right)^{n_3}}{\prod_{i=1}^{n_3} (\mu_3 + C_{3i})} \right) \dots
 \end{aligned}$$

$$\left( \frac{1}{n_{M-1}!} \left( \frac{\lambda_{M-1} + \frac{\mu_{M-2} q_{M-2} \rho_{M-2}}{(n_{M-2} + 1)(\mu_{M-2} + C_{M-2n_{M-2}+1})} + \frac{\mu_M r_M \rho_M}{(n_M + 1)(\mu_M + C_{Mn_M+1})} \right)^{n_{M-1}} \prod_{i=1}^{n_{M-1}} (\mu_{M-1} + C_{M-i}) \right) \cdot \left( \frac{1}{n_M!} \left( \frac{\lambda_M + \frac{\mu_{M-1} q_{M-1} \rho_{M-1}}{(n_{M-1} + 1)(\mu_{M-1} + C_{M-1n_{M-1}+1})} \right)^{n_M} \prod_{i=1}^{n_M} (\mu_M + C_{Mi}) \right) \cdot \left( \frac{\lambda_{11} + \frac{\mu_M q_{M1} \rho_M}{(n_M + 1)(\mu_M + C_{Mn_M+1})}}{\mu_{11}} \right)^{m_1} \cdot \left( \frac{\lambda_{12} + \frac{\mu_M q_{M2} \rho_M}{(n_M + 1)(\mu_M + C_{Mn_M+1})}}{\mu_{12}} \right)^{m_2} \dots \left( \frac{\lambda_{1N} + \frac{\mu_M q_{MN} \rho_M}{(n_M + 1)(\mu_M + C_{Mn_M+1})}}{\mu_{1N}} \right)^{m_N} \tag{3}$$

$n_i \geq 0 \ (i = 1, 2, 3, \dots, M) , m_j \geq 0 (j = 1, 2, 3, \dots, N)$

where

$$\begin{aligned}
 \rho_1 &= \lambda_1 + \frac{\mu_2 r_2 \rho_2}{(n_2 + 1)(\mu_2 + C_{2n_2+1})} \\
 \rho_2 &= \left( \lambda_2 + \frac{\mu_1 q_1 \rho_1}{(n_1 + 1)(\mu_1 + C_{1n_1+1})} + \frac{\mu_3 r_3 \rho_3}{(n_3 + 1)(\mu_3 + C_{3n_3+1})} \right) \\
 \rho_3 &= \lambda_3 + \frac{\mu_2 q_2 \rho_2}{(n_2 + 1)(\mu_2 + C_{2n_2+1})} + \frac{\mu_4 r_4 \rho_4}{(n_4 + 1)(\mu_4 + C_{4n_4+1})} \\
 &\dots \\
 &\dots \\
 &\dots \\
 \rho_{M-1} &= \lambda_{M-1} + \frac{\mu_{M-2} q_{M-2} \rho_{M-2}}{(n_{M-2} + 1)(\mu_{M-2} + C_{M-2n_{M-2}+1})} + \frac{\mu_M r_M \rho_M}{(n_M + 1)(\mu_M + C_{Mn_M+1})} \\
 \rho_M &= \lambda_M + \frac{\mu_{M-1} q_{M-1} \rho_{M-1}}{(n_{M-1} + 1)(\mu_{M-1} + C_{M-1n_{M-1}+1})}
 \end{aligned} \tag{4}$$

Solving these (4) M-equations for  $\rho_M$  with the help of determinants, we get

$$\rho_M = \frac{\left( \begin{aligned} &\lambda_M \Delta_{M-1} + \frac{q_{M-1} \mu_{M-1}}{(n_{M-1}+1)(\mu_{M-1} + C_{M-1n_{M-1}+1})} \lambda_{M-1} \Delta_{M-2} + \\ &\frac{q_{M-1} \mu_{M-1}}{(n_{M-1}+1)(\mu_{M-1} + C_{M-1n_{M-1}+1})} \cdot \frac{q_{M-2} \mu_{M-2}}{(n_{M-2}+1)(\mu_{M-2} + C_{M-2n_{M-2}+1})} \lambda_{M-2} \Delta_{M-3} + \dots \\ &\dots \\ &+ \frac{q_{M-1} \mu_{M-1}}{(n_{M-1}+1)(\mu_{M-1} + C_{M-1n_{M-1}+1})} \cdot \frac{q_{M-2} \mu_{M-2}}{(n_{M-2}+1)(\mu_{M-2} + C_{M-2n_{M-2}+1})} \dots \\ &\cdot \frac{q_3 \mu_3}{(n_3+1)(\mu_3 + C_{3n_3+1})} \lambda_3 \Delta_2 \\ &+ \frac{q_{M-1} \mu_{M-1}}{(n_{M-1}+1)(\mu_{M-1} + C_{M-1n_{M-1}+1})} \cdot \frac{q_{M-2} \mu_{M-2}}{(n_{M-2}+1)(\mu_{M-2} + C_{M-2n_{M-2}+1})} \dots \\ &\cdot \frac{q_3 \mu_3}{(n_3+1)(\mu_3 + C_{3n_3+1})} \cdot \frac{q_2 \mu_2}{(n_2+1)(\mu_2 + C_{2n_2+1})} \lambda_2 \Delta_1 \\ &+ \frac{q_{M-1} \mu_{M-1}}{(n_{M-1}+1)(\mu_{M-1} + C_{M-1n_{M-1}+1})} \cdot \frac{q_{M-2} \mu_{M-2}}{(n_{M-2}+1)(\mu_{M-2} + C_{M-2n_{M-2}+1})} \dots \\ &\cdot \frac{q_3 \mu_3}{(n_3+1)(\mu_3 + C_{3n_3+1})} \cdot \frac{q_2 \mu_2}{(n_2+1)(\mu_2 + C_{2n_2+1})} \cdot \frac{q_1 \mu_1}{(n_1+1)(\mu_1 + C_{1n_1+1})} \lambda_1 \end{aligned} \right)}{\left( \Delta_{M-1} - \frac{q_{M-1} \mu_{M-1}}{(n_{M-1}+1)(\mu_{M-1} + C_{M-1n_{M-1}+1})} \cdot \frac{r_M \mu_M}{(n_M+1)(\mu_M + C_{Mn_M+1})} \Delta_{M-2} \right)} \tag{5}$$

where

$$\Delta_M = \Delta_{M-1} - \frac{q_{M-1} \mu_{M-1}}{(n_{M-1}+1)(\mu_{M-1} + C_{M-1n_{M-1}+1})} \cdot \frac{r_M \mu_M}{(n_M+1)(\mu_M + C_{Mn_M+1})} \Delta_{M-2}$$

and  $\Delta_1 = 1$

$$\Delta_2 = \begin{vmatrix} & \frac{r_2 \mu_2}{n_2+1} \\ 1 & -\frac{\mu_2 + c_{2n_2+1}}{\mu_2 + c_{2n_2+1}} \\ \frac{q_1 \mu_1}{n_1+1} & \\ \mu_1 + c_{1n_1+1} & 1 \end{vmatrix}$$

$$\Delta_3 = \begin{vmatrix} 1 & -\frac{r_2 \mu_2}{n_2 + 1} & 0 \\ \frac{q_1 \mu_1}{n_1 + 1} & 1 & -\frac{r_3 \mu_3}{n_3 + 1} \\ \mu_1 + c_{1n_1+1} & \mu_2 + c_{2n_2+1} & \mu_3 + c_{3n_3+1} \end{vmatrix}$$

$$\dots$$

$$\dots$$

$$\dots \tag{6}$$

$$\Delta_M = \begin{vmatrix} 1 & -\frac{r_2 \mu_2}{n_2 + 1} & 0 & 0 & \dots & 0 & 0 & 0 \\ \frac{q_1 \mu_1}{n_1 + 1} & 1 & -\frac{r_3 \mu_3}{n_3 + 1} & 0 & \dots & 0 & 0 & 0 \\ 0 & -\frac{q_2 \mu_2}{n_2 + 1} & 1 & -\frac{r_4 \mu_4}{n_4 + 1} & \dots & 0 & 0 & 0 \\ \dots & \dots & \dots & \dots & \dots & \dots & \dots & \dots \\ 0 & 0 & 0 & 0 & \dots & -\frac{q_{M-2} \mu_{M-2}}{n_{M-2} + 1} & 1 & -\frac{r_M \mu_M}{n_M + 1} \\ 0 & 0 & 0 & 0 & \dots & \dots & -\frac{q_{M-1} \mu_{M-1}}{n_{M-1} + 1} & 1 \end{vmatrix}$$

Since  $\rho_M$  is obtained, so we can get  $\rho_{M-1}$  by putting the value of  $\rho_M$  in the last equation of (4),  $\rho_{M-2}$  by putting the values of  $\rho_{M-1}$  and  $\rho_M$  in the last but one equation of (4) Continuing in this way, we shall obtain  $\rho_{M-3}, \rho_{M-4}, \dots, \rho_3, \rho_2$  and  $\rho_1$ .

Thus, we write (3) as under

$$P(\rho_1, \rho_2, \dots, \rho_M) = P(\rho_1, \rho_2, \dots, \rho_M) \left( \frac{1}{n_1!} \frac{(\rho_1)^{n_1}}{\prod_{i=1}^{n_1} (\mu_1 + C_{1i})} \right) \left( \frac{1}{n_2!} \frac{(\rho_2)^{n_2}}{\prod_{i=1}^{n_2} (\mu_2 + C_{2i})} \right) \left( \frac{1}{n_3!} \frac{(\rho_3)^{n_3}}{\prod_{i=1}^{n_3} (\mu_3 + C_{3i})} \right) \dots$$

$$\left( \frac{1}{n_{M-1}!} \frac{(\rho_{M-1})^{n_{M-1}}}{\prod_{i=1}^{n_{M-1}} (\mu_{M-1} + C_{M-i})} \right) \left( \frac{1}{n_M!} \frac{(\rho_M)^{n_M}}{\prod_{i=1}^{n_M} (\mu_M + C_{Mi})} \right) \left( \frac{\lambda_{11} + \frac{\mu_M q_{M1} \rho_M}{(n_M + 1)(\mu_M + C_{Mn_M+1})}}{\mu_{11}} \right)^{m_1}$$

$$\cdot \left( \frac{\lambda_{12} + \frac{\mu_M q_{M2} \rho_M}{(n_M + 1)(\mu_M + C_{Mn_M+1})}}{\mu_{12}} \right)^{m_2} \dots \left( \frac{\lambda_{1N} + \frac{\mu_M q_{MN} \rho_M}{(n_M + 1)(\mu_M + C_{Mn_M+1})}}{\mu_{1N}} \right)^{m_N} \quad (7)$$

$$n_i \geq 0 \quad (i = 1, 2, 3, \dots, M), \quad m_j \geq 0 \quad (j = 1, 2, 3, \dots, N)$$

We obtain  $P(\theta_0, \theta_0)$  from the normalizing conditions.

$$\sum_{n_i = \theta_i, n_j = \theta_j}^{\infty} P(n_i, n_j) = 1 \quad (8)$$

and with the restriction that traffic intensity of each service channel of the system is less than unity. Here it is mentioned that the customers leave the system at constant rate as long as there is a line, provided that the customers are served in the order in which they arrive.

Putting  $C_{in_i} = C_i \quad (i = 1, 2, 3, \dots, M)$  in the steady-state solution (3) then

$\rho_i \quad (i = 1, 2, 3, \dots, M)$  will change accordingly and the steady-state solution reduces to

$$P(n_1, n_2, \dots, n_M) = P(\theta_0, \theta_0) \left( \frac{1}{n_1!} \left( \frac{\rho_1}{\mu_1 + C_1} \right)^{n_1} \right) \left( \frac{1}{n_2!} \left( \frac{\rho_2}{\mu_2 + C_2} \right)^{n_2} \right) \left( \frac{1}{n_3!} \left( \frac{\rho_3}{\mu_3 + C_3} \right)^{n_3} \right) \dots$$

$$\left( \frac{1}{n_{M-1}!} \left( \frac{\rho_{M-1}}{\mu_{M-1} + C_{M-1}} \right)^{n_{M-1}} \right) \left( \frac{1}{n_M!} \left( \frac{\rho_M}{\mu_M + C_M} \right)^{n_M} \right) \cdot \left( \frac{\lambda_{11} + \frac{\mu_M q_{M1} \rho_M}{(n_M + 1)(\mu_M + C_M)}}{\mu_{11}} \right)^{m_1}$$

$$\left( \frac{\lambda_{12} + \frac{\mu_M q_{M2} \rho_M}{(n_M + 1)(\mu_M + C_M)}}{\mu_{12}} \right)^{m_2} \dots \left( \frac{\lambda_{1N} + \frac{\mu_M q_{MN} \rho_M}{(n_M + 1)(\mu_M + C_M)}}{\mu_{1N}} \right)^{m_N} \quad (9)$$

We obtain  $P(\theta_0, \theta_0)$  from (8) and (9) as

$$\left( P(\theta_0, \theta_0) \right)^{-1} = \prod_{i=1}^M e^{\frac{\rho_i}{\mu_i + C_i}} \prod_{j=1}^N \frac{1}{1 - \rho_{1j}}$$

where

$$\rho_{1j} = \frac{\lambda_{1j} + \frac{\mu_M q_{Mj} \rho_M}{(n_M + 1)(\mu_M + C_M)}}{\mu_{1j}}, \quad j = 1, 2, 3, \dots, N$$



Thus  $P(n_1)$  is completely determined.

### 6 Steady-State Marginal Probabilities

Let  $P(n_1)$  be the steady-state marginal probability that there are  $n_1$  units in the queue before the first server. This is determined as

$$\begin{aligned}
 P(n_1) &= \sum_{n_2, n_3, \dots, n_M=0}^{\infty} \sum_{n_0=0}^{\infty} P(n_1, n_2, \dots, n_M, n_0) \\
 &= \sum_{n_2, n_3, \dots, n_M=0}^{\infty} \sum_{n_0=0}^{\infty} P(n_0, n_2, \dots, n_M, n_0) \left( \frac{1}{n_1!} \left( \frac{\rho_1}{\mu_1 + C_1} \right)^{n_1} \right) \left( \frac{1}{n_2!} \left( \frac{\rho_2}{\mu_2 + C_2} \right)^{n_2} \right) \left( \frac{1}{n_3!} \left( \frac{\rho_3}{\mu_3 + C_3} \right)^{n_3} \right) \dots \\
 &\quad \left( \frac{1}{n_{M-1}!} \left( \frac{\rho_{M-1}}{\mu_{M-1} + C_{M-1}} \right)^{n_{M-1}} \right) \left( \frac{1}{n_M!} \left( \frac{\rho_M}{\mu_M + C_M} \right)^{n_M} \right) \cdot (\rho_{11})^{m_1} (\rho_{12})^{m_2} \dots (\rho_{1N})^{m_N}
 \end{aligned}$$

Thus 
$$P(n_1) = \frac{1}{n_1!} \left( \frac{\rho_1}{\mu_1 + C_1} \right)^{n_1} e^{-\left( \frac{\rho_1}{\mu_1 + C_1} \right)} \quad n_1 > 0$$

Similarly

$$P(n_2) = \frac{1}{n_2!} \left( \frac{\rho_2}{\mu_2 + C_2} \right)^{n_2} e^{-\left( \frac{\rho_2}{\mu_2 + C_2} \right)} \quad n_2 > 0$$

-----  
-----

$$P(n_M) = \frac{1}{n_M!} \left( \frac{\rho_M}{\mu_M + C_M} \right)^{n_M} e^{-\left( \frac{\rho_M}{\mu_M + C_M} \right)} \quad n_M > 0$$

Further let  $P(m_1), P(m_2), P(m_3), \dots, P(m_N)$  be the steady-state marginal probabilities that there are  $m_1, m_2, m_3, \dots, m_N$  customers waiting before server  $S_i (i=1, 2, 3, \dots, N)$  respectively.

$$\begin{aligned}
 P(m_1) &= \sum_{n_0=0}^{\infty} \sum_{m_2, m_3, \dots, m_N=0}^{\infty} P(n_0, m_2, m_3, \dots, m_N, n_0) \\
 &= \sum_{n_0=0}^{\infty} \sum_{m_2, m_3, \dots, m_N=0}^{\infty} P(n_0, m_2, m_3, \dots, m_N, n_0) \left( \frac{1}{n_1!} \left( \frac{\rho_1}{\mu_1 + C_1} \right)^{n_1} \right) \left( \frac{1}{n_2!} \left( \frac{\rho_2}{\mu_2 + C_2} \right)^{n_2} \right) \left( \frac{1}{n_3!} \left( \frac{\rho_3}{\mu_3 + C_3} \right)^{n_3} \right) \dots \\
 &\quad \left( \frac{1}{n_{M-1}!} \left( \frac{\rho_{M-1}}{\mu_{M-1} + C_{M-1}} \right)^{n_{M-1}} \right) \left( \frac{1}{n_M!} \left( \frac{\rho_M}{\mu_M + C_M} \right)^{n_M} \right) \cdot (\rho_{11})^{m_1} (\rho_{12})^{m_2} \dots (\rho_{1N})^{m_N} \\
 &= (\rho_{11})^{m_1} (1 - \rho_{11}); \quad m_1 > 0
 \end{aligned}$$

Similarly

$$P(m_2) = (\rho_{12})^{m_2} (1 - \rho_{12}) \quad m_2 > 0$$

.....

$$P(m_N) = (\rho_{1N})^{m_N} (1 - \rho_{1N}) \quad m_N > 0$$

### 7 Mean Queue Length

Mean queue length before the server  $S_1$  is determined by

$$\begin{aligned} L_1 &= \sum_{n_1=0}^{\infty} n_1 P(n_1) = \sum_{n_1=0}^{\infty} n_1 \frac{1}{n_1!} \left( \frac{\rho_1}{\mu_1 + C_1} \right)^{n_1} e^{-\left(\frac{\rho_1}{\mu_1 + C_1}\right)} \\ &= \frac{\rho_1}{\mu_1 + C_1} \end{aligned}$$

Similarly,  $L_2 = \frac{\rho_2}{\mu_2 + C_2}$

-----  
-----

$$L_M = \frac{\rho_M}{\mu_M + C_M}$$

Mean queue length before the server  $S_{11}$  is determined as

$$L_{11} = \frac{\rho_{11}}{1 - \rho_{11}}$$

Similarly

$$L_{1j} = \frac{\rho_{1j}}{1 - \rho_{1j}} \quad j = 2, 3, \dots, N$$

Hence mean queue length of the system is

$$L = \sum_{k=1}^M L_k + \sum_{j=1}^N L_{1j}$$

### Model B

#### 8 Formulation of Equations

Here we assume that at any instant there are K customers in the system i.e.

$$\sum_{i=1}^M n_i + \sum_{j=1}^N m_j = K .$$

Then the customers arriving at that instant will not be allowed to join the system and is considered lost for the system. Define  $P(n_1, n_2, n_3, \dots, n_M, m_1, m_2, m_3, \dots, m_N, t)$  and operators  $T_i, T_i, T_{i,i+1}, T_{i-1,i}$  to act upon the vectors  $n = (n_1, n_2, n_3, \dots, n_M)$  or  $m = (m_1, m_2, m_3, \dots, m_N)$  as in model A.

Following the procedure given by Kelly, we write the difference – differential equations as

$$\begin{aligned} \frac{d P(n, m, t)}{dt} &= - \left[ \sum_{i=1}^M \frac{\lambda_i}{n_i + 1} + \sum_{i=1}^M \delta(n_i) (\mu_i + C_{i1}) + \sum_{j=1}^N \lambda_j + \sum_{j=1}^N \delta(m_j) \mu_j \right] P(n, m, t) \\ &+ \sum_{i=1}^M \frac{\lambda_i}{n_i} P(T_i(n, m, t)) + \sum_{i=1}^M (\mu_i + C_{i1}) P(T_i(n, m, t)) \end{aligned}$$

$$\begin{aligned}
 & + \sum_{i=1}^{M-1} \mu_i \frac{q_i}{n_{i+1}} P(T_{\cdot, i+1}(\lambda, \mu, t)) + \sum_{i=1}^M \mu_i \frac{r_i}{n_{i-1}} P(T_{i-1, \cdot, i}(\lambda, \mu, t)) \\
 & + \sum_{j=1}^N \mu_M q_{Mj} P(n_1, n_2, \dots, n_M + 1, T_j(\lambda, \mu, t)) + \sum_{j=1}^N \lambda_j P(\lambda T_j(\lambda, \mu, t)) \\
 & + \sum_{j=1}^N \mu_j P(\lambda T_j(\lambda, \mu, t))
 \end{aligned} \tag{10}$$

for  $n_i \geq 0$  ( $i = 1, 2, 3, \dots, M$ ),  $m_j \geq 0$  ( $j = 1, 2, 3, \dots, N$ );

and  $P(\lambda, \mu, t) = 0$  if any of the arguments in negative.

$$\begin{aligned}
 \frac{d P(\lambda, \mu, t)}{dt} = & - \left[ \sum_{i=1}^M \delta(n_i) (\mu_i + C_{in_i}) + \sum_{j=1}^N \delta(m_j) \mu_j \right] P(\lambda, \mu, t) \\
 & + \sum_{i=1}^M \frac{\lambda_i}{n_i} P(T_i(\lambda, \mu, t)) + \sum_{i=1}^{M-1} \mu_i \frac{q_i}{n_{i+1}} P(T_{\cdot, i+1}(\lambda, \mu, t)) \\
 & + \sum_{j=1}^N \mu_M q_{Mj} P(n_1, n_2, \dots, n_M + 1, T_j(\lambda, \mu, t)) + \sum_{j=1}^N \lambda_j P(\lambda T_j(\lambda, \mu, t))
 \end{aligned} \tag{11}$$

for  $n_i \geq 0$  ( $i = 1, 2, 3, \dots, M$ ),  $m_j \geq 0$  ( $j = 1, 2, 3, \dots, N$ );

where

$$\delta(x) = \begin{cases} 1 & \text{if } x \neq 0 \\ 0 & \text{if } x = 0 \end{cases} \quad \text{and} \quad \sum_{i=1}^M n_i + \sum_{j=1}^N m_j = K.$$

### 9 Steady-State Equations

We write the following steady-state equations of the queuing model by equating the time derivative to zero in equations (10) and (11).

$$\begin{aligned}
 & \left[ \sum_{i=1}^M \frac{\lambda_i}{n_i + 1} + \sum_{i=1}^M \delta(n_i) (\mu_i + C_{in_i}) + \sum_{j=1}^N \lambda_j + \sum_{j=1}^N \delta(m_j) \mu_j \right] P(\lambda, \mu) \\
 & = \sum_{i=1}^M \frac{\lambda_i}{n_i} P(T_i(\lambda, \mu)) + \sum_{i=1}^M (\mu_i p_i + C_{in_{i+1}}) P(T_{\cdot, i}(\lambda, \mu)) \\
 & + \sum_{i=1}^{M-1} \mu_i \frac{q_i}{n_{i+1}} P(T_{\cdot, i+1}(\lambda, \mu)) + \sum_{i=1}^M \mu_i \frac{r_i}{n_{i-1}} P(T_{i-1, \cdot, i}(\lambda, \mu)) \\
 & + \sum_{j=1}^N \mu_M q_{Mj} P(n_1, n_2, \dots, n_M + 1, T_j(\lambda, \mu)) + \sum_{j=1}^N \lambda_j P(\lambda T_j(\lambda, \mu)) + \sum_{j=1}^N \mu_j P(\lambda T_j(\lambda, \mu))
 \end{aligned} \tag{12}$$

for  $n_i \geq 0$  ( $i = 1, 2, 3, \dots, M$ ),  $m_j \geq 0$  ( $j = 1, 2, 3, \dots, N$ ); and  $\sum_{i=1}^M n_i + \sum_{j=1}^N m_j < K$ .

$$\begin{aligned}
 & \left[ \sum_{i=1}^M \delta(n_i) (\mu_i + C_{in_i}) + \sum_{j=1}^N \delta(m_j) \mu_j \right] P(\lambda, \mu) = \sum_{i=1}^M \frac{\lambda_i}{n_i} P(T_i(\lambda, \mu)) \\
 & + \sum_{i=1}^{M-1} \mu_i \frac{q_i}{n_{i+1}} P(T_{\cdot, i+1}(\lambda, \mu)) + \sum_{i=1}^M \mu_i \frac{r_i}{n_{i-1}} P(T_{i-1, \cdot, i}(\lambda, \mu)).
 \end{aligned}$$

$$+ \sum_{j=1}^N \mu_M q_{Mj} P(n_1, n_2, \dots, n_M + 1, T_j, \cdot(\mathbb{N})) + \sum_{j=1}^N \lambda_j P(\mathbb{N} T_j, \cdot(\mathbb{N})) \tag{13}$$

where

$$\delta(x) = \begin{cases} 1 & \text{if } x \neq 0 \\ 0 & \text{if } x = 0 \end{cases}$$

$$n_i \geq 0 \quad (i = 1, 2, 3, \dots, M), \quad m_j \geq 0 \quad (j = 1, 2, 3, \dots, N); \quad \text{and} \quad \sum_{i=1}^M n_i + \sum_{j=1}^N m_j = K .$$

### 10 Steady-State Solutions

The solutions of the Steady-State equations (12) can be verified to be

$$P(\mathbb{N}, \mathbb{N}) = P(\mathbb{0}, \mathbb{0}) \left[ \frac{1}{n_1!} \frac{\left( \lambda_1 + \frac{\mu_2 r_2 \rho_2}{(n_2 + 1)(\mu_2 + C_{2n_2+1})} \right)^{n_1}}{\prod_{i=1}^{n_1} (\mu_1 + C_{1i})} \right] \cdot \left[ \frac{1}{n_2!} \frac{\left( \lambda_2 + \frac{\mu_1 q_1 \rho_1}{(n_1 + 1)(\mu_1 + C_{1n_1+1})} + \frac{\mu_3 r_3 \rho_3}{(n_3 + 1)(\mu_3 + C_{3n_3+1})} \right)^{n_2}}{\prod_{i=1}^{n_2} (\mu_2 + C_{2i})} \right] \cdot \left[ \frac{1}{n_3!} \frac{\left( \lambda_3 + \frac{\mu_2 q_2 \rho_2}{(n_2 + 1)(\mu_2 + C_{2n_2+1})} + \frac{\mu_4 r_4 \rho_4}{(n_4 + 1)(\mu_4 + C_{4n_4+1})} \right)^{n_3}}{\prod_{i=1}^{n_3} (\mu_3 + C_{3i})} \right] \dots \cdot \left[ \frac{1}{n_{M-1}!} \frac{\left( \lambda_{M-1} + \frac{\mu_{M-2} q_{M-2} \rho_{M-2}}{(n_{M-2} + 1)(\mu_{M-2} + C_{M-2n_{M-2}+1})} + \frac{\mu_M r_M \rho_M}{(n_M + 1)(\mu_M + C_{Mn_M+1})} \right)^{n_{M-1}}}{\prod_{i=1}^{n_{M-1}} (\mu_{M-1} + C_{M-1i})} \right] \cdot \left[ \frac{1}{n_M!} \frac{\left( \lambda_M + \frac{\mu_{M-1} q_{M-1} \rho_{M-1}}{(n_{M-1} + 1)(\mu_{M-1} + C_{M-1n_{M-1}+1})} \right)^{n_M}}{\prod_{i=1}^{n_M} (\mu_M + C_{Mi})} \right] \cdot \left[ \frac{\lambda_{11} + \frac{\mu_M q_{M1} \rho_M}{(n_M + 1)(\mu_M + C_{Mn_M+1})}}{\mu_{11}} \right]^{m_1}$$

$$P(n_1, n_2, \dots, n_M) = \frac{\left( \lambda_{12} + \frac{\mu_M q_{M2} \rho_M}{(n_M + 1)(\mu_M + C_{Mn_M+1})} \right)^{m_2}}{\mu_{12}} \dots \frac{\left( \lambda_{1N} + \frac{\mu_M q_{MN} \rho_M}{(n_M + 1)(\mu_M + C_{Mn_M+1})} \right)^{m_N}}{\mu_{1N}} \quad (14)$$

$$n_i \geq 0 \quad (i = 1, 2, 3, \dots, M) , m_j \geq 0 \quad (j = 1, 2, 3, \dots, N)$$

where  $\rho_1, \rho_2, \rho_3, \dots, \rho_M$  are same as in model A.

$P(n_1, n_2, \dots, n_M)$  can be determined from the normalizing condition  $\sum_{n_i=0}^K \sum_{m_j=0}^K P(n_1, n_2, \dots, n_M) = 1$  with the

relation  $\sum_{i=1}^M n_i + \sum_{j=1}^N m_j \leq K$  and with the restriction that traffic intensity of each service channel is less than unity. Here, it is mentioned that customers leave the system at a constant rate as long as there is a line, provided customers are served in the order in which they arrive. Putting  $C_{im_i} = C_i \quad (i = 1, 2, 3, \dots, N)$ .

The steady-state solution (14) reduces to

$$P(n_1, n_2, \dots, n_M) = P(0, 0, \dots, 0) \left( \frac{1}{n_1!} \left( \frac{\rho_1}{\mu_1 + C_1} \right)^{n_1} \right) \left( \frac{1}{n_2!} \left( \frac{\rho_2}{\mu_2 + C_2} \right)^{n_2} \right) \left( \frac{1}{n_3!} \left( \frac{\rho_3}{\mu_3 + C_3} \right)^{n_3} \right) \dots$$

$$\left( \frac{1}{n_{M-1}!} \left( \frac{\rho_{M-1}}{\mu_{M-1} + C_{M-1}} \right)^{n_{M-1}} \right) \left( \frac{1}{n_M!} \left( \frac{\rho_M}{\mu_M + C_M} \right)^{n_M} \right) \cdot \left( \frac{\lambda_{11} + \frac{\mu_M q_{M1} \rho_M}{(n_M + 1)(\mu_M + C_M)}}{\mu_{11}} \right)^{m_1}$$

$$\cdot \left( \frac{\lambda_{12} + \frac{\mu_M q_{M2} \rho_M}{(n_M + 1)(\mu_M + C_M)}}{\mu_{12}} \right)^{m_2} \dots \left( \frac{\lambda_{1N} + \frac{\mu_M q_{MN} \rho_M}{(n_M + 1)(\mu_M + C_M)}}{\mu_{1N}} \right)^{m_N} \quad (15)$$

with relation  $\sum_{i=1}^M n_i + \sum_{j=1}^N m_j \leq K$

We obtain  $P(n_1, n_2, \dots, n_M)$  from the normalizing condition  $\sum_{n_i=0}^K \sum_{m_j=0}^K P(n_1, n_2, \dots, n_M) = 1$  with the relation

$$\sum_{i=1}^M n_i + \sum_{j=1}^N m_j \leq K .$$

Thus  $P(n_1, n_2, \dots, n_M)$  is completely determined.

### **References**

- [1] Finch, P.D (1959) : Cyclic queues. *Opns. Res. Quart*, Vol. 9, No. 1.
- [2] Jackson, R.R. P(1954) : Queuing system with phase type service. *operat. Res. Quart.* 109-120.
- [3] Hunt, G.C. (1955) : Sequential arrays of waiting lines. *opps. Res.* Vol. 4, No. 6.
- [4] Kelly, F.P (1976): *Network of a queues.* *Adv. Prob.* 8,416-432.
- [5] Kelly, F.P (1979) : *Reversibility and stochastic networks.* Wiley, New York.
- [6] O'Brien, G.G. (1954): *The solution of some queuing problems.* *J.Soc. Ind. Appl. Math* Vol. 2, 132-142.
- [7] Singh.M. (1984); *Steady-state behaviour of serial queuing processes with impatient customers.* *Math. operations forsch, U.statist. Ser. Statist.* Vol. 15. No 2, 289-298.



## **Impact Of Hrm Practices On Employee Performance In Selected Financial Institution Of Jaipur And Jodhpur**

**Dr. Ashish Mathur\***

### **Abstract**

This article aims to study the influence of the HRM Practices on the financial institutions of being run in the country, specifically on the basis of performance of the employees at financial institutions of Rajasthan. The study encompasses or clearly states about the HRM practice (Training, Performance appraisal, and employee participation) which act as an independent variable and an important deciding factor and the factor like that of employee performance which act as a dependent variable for the organization. The study is targeting or is specifically about selected employees who are working in a healthy environment of the financial institutions of Jaipur and Jodhpur a known City of Rajasthan. Samples were collected by the medium using a questionnaire which were being filled by 70 employees in order to start the hypothesis test for further result or output. Regression analysis was done on the collected data from the employee of the organization using SPSS software to know the outcome/impact of independent variables on the performance of workers in an organization or what affect the performance of the employee. It was found after the test that there were a significant relationship and impact being left by the training provided by the trainers to these employee and performance appraisal which are annually made and these plans on employee performance whereas employee participation which is found to be putting less impact on employee performance. The study was concluded with the outcomes and with many results and one of the most important which was found during the test which is that there exist a positive connection between the various HRM practices going on in financial institutions and the employees' performance in an industry.

### **Introduction**

With the arrival of HRM, recently, researchers interest are growing and hence they are paying much consideration to this, precisely about the effect of various human resource practices which are being done on the performance of organizations and employees' attitudes which is today's' an motivating research area particularly in the situation among the advanced countries. However the knowledge available about impact of HRM is still insufficient. **(Sarbariy, 2011).**

We are breathing in such an era which is highly organized where the commercial world is becoming more of like a village and the business organizations of today's' time are facing cutthroat struggle among themselves from place to place around the globe. It can be observed that one of the important source of modest advantage in current time for any corporate is its human resources **(Becker & Huselid, 1998).**

The business environment concept of today's' era and way of doing the complete business are changing rapidly according to the demand of the time and it has made it necessary for every type of business units which is currently being run to adopt the human resource

---

\* Associate Professor, Department of Commerce, Faculty of Commerce and Management, Indira Gandhi National Tribal University, Amarakantak, Madhya Pradesh

management practices for efficient work and for proper development to compete in their industries and to make success all throughout. The impact or the output of human resource management practices which is done on by the organization on employee performance has been the concentrated and the demanding research area in recent past and even can be seen that a lot of studies have been conducted to validate this relationship and to find the output of it.

In India, enormous research work is going on and also has been done to examine and understand the actual lying consequence of various human resource management practices in an organization at present and employee performance based on it but in actual if we talk very few research is seen in the financial sector. For the sake of penetrating this relationship in the context of a country like India, more research is really required. So, this study is supposed or thought to overcome or find the necessary evidence, which helps people to understand the Impact of HRM practices which are done in the organization on employee performance in the financial sector of Jaipur and Jodhpur.

### **Literature Review**

#### **● HRM**

Human resource management (HRM) is one of important concern of today which refers or defines to the different policies and in numerous performs which are made in any industry or is convoluted in booming out the different 'human resource(HR)' aspects which are there for a management position of any reputed industry including human resource planning done for industry, job analysis for the firm, recruitment process of employee, selection process, orientation, compensation, performance appraisal which is done annually , training and development provided to employee and labor relations (**Aguinis, 2009**).

HRM is composed of the various policies, and different practice and system that influence employee's behavior towards their organization, their attitude which could be healthy or not and performance whether up or down (**Altarawmneh, and Kilani, 2010**).

**Guest (2002)** has argued or has clearly stated that the Impact of HRM which is left on the performance of the working employee in an institution specifically depends upon employees response or reactions to the existing various HRM practices which is being practiced or carried out in an organization, so the impact will change accordingly in the very same direction towards the perception of HRM practices being practiced by the employee in an organization. **Wood (1999) and Guest (2002)** has hassled or has clearly defined that a capable, committed HR policies towards the organization and which is highly involved and has workforce for the firm is the one which is required for best and proper implementation of business strategy.

**Huselid (1995)** have found that the usefulness and the efficacy of employees towards their work dedication will depend on impact or the output of HRM which leave an effect on the behavior and the attitude of the employees. **Patterson et al (1997)** has put his thought that on various management practices which are run in the organization has left a strong impulsive effect on the business performance and has argued that HR practices which are there for the selection of the new employee and training process which follows after selection process have severely influenced the performance by providing them with appropriate skills which are required by them during their work process. The research done by them has evidently found that HR practices which are there in organization have left a strong and inspiring impact on employee performance in future even if they are counted in terms of productivity in the organization.

● **EMPLOYEE PERFORMANCE**

According to the views of **McDuffie (1995)**, we can believe that basically or commonly in an organization of finance there are three types of data for the employee performance measurement which are easily available for research and for the study, which include qualitative type where quality is prior important (like that of customer complaints which are very specific, number of errors which needs to be define) or quantitative where amount matters (no of customers who are served, amount of units being produced), measurement of time (no of absence, what was the last working time, work lateness and when the employee fails to meet deadlines) and also there are some financial indicators that consists of a large array of possibilities (**Brown, 2009**).

For this study to be done completely, the measures for employee performance is required and will be adopted from established empirical studies which for sure links HRM practices in an organization and the employee performance to each other. Human resource management researchers who are still doing also and practitioners who are at present have increasingly stressed or information about the utility form in overcoming the strategic or the required goals which are important for the organization. Organizations that really show their personal interest to invest in "best" HRM practices for the organization which will for sure increase firm productivity and on the same side will increase profitability of the firm (**Chatterjee and Pearson, 2000**).

● **EMPLOYEE PARTICIPATION**

HR professionals who are there in the organization must focus on continuous innovation which is currently going on by responding or giving reply definitely to new philosophies and continuously keeping track or records of new tendencies which are going continuously. Innovative HR interventions are currently being designed to ensure that people should respond spontaneously as every response is important to the critical demand of the organizations, as these HR peoples have marvelous potential to shape healthy and fruitful organizations (**Noe, Hollenbeck, Gerhart and Wright, 2007**).

Employees of today's time exchange or discuss their genuine exertion which is important for their greater care, worry about others and sustenance which they received or learn mostly from their organizations as in organization unity is important (**Eisenberger, Huntington, and Sava, 1986**). Similarly it is seen that, **DeCotiis and Summers (1987)** described or stated that when employees were pickled with deliberation or with great care, they displayed greater levels of commitment towards their work.

● **TRAINING AND DEVELOPMENT**

"Training is systematic and complete development of the knowledge, skills, and attitudes and even it increases knowledge and is required by every individual in their life to perform adequately and easily a given task or any kind of job" (**Armstrong, 2006**).

According to **Harel and Tzafrir (1999)**, he put his views about training that training can actually effect the enactment of any employee by refining their abilities and techniques which they previously own relevant to employees' tasks and their personal development

● **PERFORMANCE APPRAISAL**

Performance appraisal is used by every organization which work with norms and regulations to calculate employees' hard work so as to reward the employees on its basis for their efforts and hence for their future development (**Collins and Clark, 2003**). Performance appraisal which is of employee but is indirectly related to organization and it was also found to have that these appraisal of employees are somehow affecting both

directly and indirectly the various administrative performance of the existing employee as it is all about employee recognition and even the feedback which is very important and which is obtained on the basis of performance appraisal activities are done in firm, and is usually conducted at least once annually or according to firm norms which can help to improve administrative processes in future as well as in present (**Collins and Clark, 2003**).

### **Research Objective**

The main purpose or the thought behind this study was to identify the impact of various HR practices which is important from employee perception on Employee performance. To accomplish this objective, the subsequent specific objectives are detailed:

- To examine and to identify the connection, which exists between HRM in an organization and employees' performance in the financial institution.
- To explore the affiliation which is important between various HRM practices and the resultant employees' performance in an organization through the three important and currently occurring major HR practices which is known as employee participation, training and development and performance appraisal.

### **Scope Of Study**

The investigation which is stated here is carried out in the appropriate way is scoped to the final and conclude evaluation of the impact which is made by HRM in the organization of financial terms on employees' performance directly and indirectly via employee participation, training & development being provided to employee and performance appraisal in the setting of financial institutions of Rajasthan.

### **Data Collection**

The data is collected through the medium of a survey, by the means of a questionnaire which was framed properly by keeping in mind every perception related to topic. As this study which we are talking now is about the HRM and performance of the employee, and there is need to understand the impact by following the Quantitative approach and hence method was chosen accordingly. Rationale for the assortment is by close-ended queries instead of bearing interviews which is not appropriate and to find the relationship which is existing between different variables and comparisons is made between the various respondents (**Brayman & Bell, 2007**).

The data in this article were used for the study which were gained from both Primary and Secondary Data sources. The Primary sources from where data has been collected include direct information collected through direction of questionnaires which is being prepared in order to gain deep insight into the research topic and to have more awareness about the topic. The secondary data sources which is in the article include various journals, many textbooks related to it and other various related publication which could be both online and offline. Data were collected through the administering of questionnaires which was prepared previously to all the employees of the financial sector which is in taken for the study like from the two provinces (Jaipur and Jodhpur). The questions were created or structured in such a manner as to have complete awareness about related topic and to test the hypothesis mentioned in the study.

The financial sector is very vast. Therefore it is nearly impossible for this type of study to carry out a survey on all the famous institution's employees. Hence, this study which is done was adopted with the thought of a convenient sampling method to select a proper required sample from the total population under consideration to conduct the research and

to reach to some output. Hence it can be inferred that the sample size for the study for this was done with 70 employees who was employed in the different banks of city like Jaipur and Jodhpur.

**Data Analysis**

Statistical analysis software was used to analyze the gathered data to know different views and perception of people. The software named Statistical Package for Social Sciences (SPSS) was used and the version 21 was used of this software in this article to analyze the genuine data which was being collected during the article writing. The SPSS software is the good one and hence was used all throughout to perform various types of descriptive or explanatory statistics such as some of the correlation analysis which is common one, regression analysis which needs to be know, and then it was made to compare the differences existing or was found in the regression coefficient stated in the article. Pearson's Correlation Co-efficient method was used in this and was successfully adopted for data analysis approach. In this article the above mentioned technique was made to be use to test or to see the relationship which was existing between various HR practices which is being performed in the organization and the performance of all the employees in the same organization.

**Demographic Analysis:**

**Table 1:- Frequency table of the age of respondents**

Age	Age	Frequency	Percent	Valid Percent	Cumulative Percent
Valid	18 - 25	12	17.15	17.15	17.15
	26 -35	25	35.72	35.72	52.87
	36-45	18	25.71	25.71	78.58
	Above 45	15	21.42	21.42	100
	Total	70	100	100	

**Graph 1:- Frequency Graph of the age of respondents**

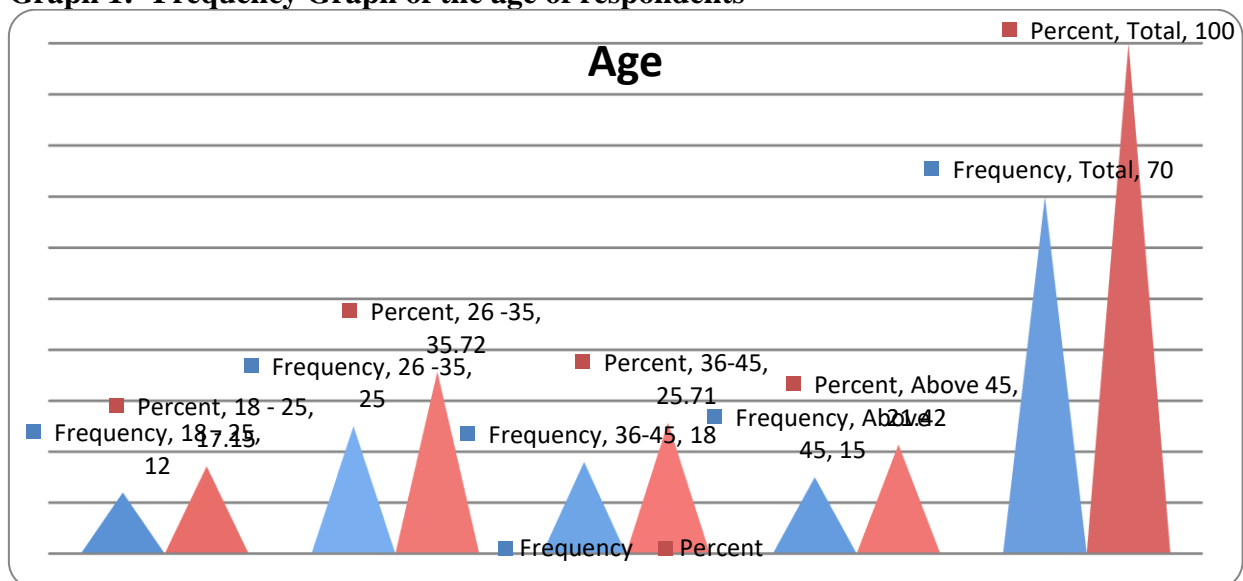

According to the table 1, The average age of respondents which can be seen in the table and graph is above 45 years old which account for 21.42% it shows that the data has been



collected from senior age person also, fewer than 25 years old accounted for 17.15% and it shows that small age group people were also considered for data collection as they are also important part, 26 to 35years old accounted for 35.72% they are the youth of today's' time, and 36 to 45 years old accounted for 25.71% they are the mature person who is aware of their responsibility.

**Table 2:- Frequency table of Gender class of respondents**

Gender					
	Age	Frequency	Percent	Valid Percent	Cumulative Percent
Valid	Male	29	41.42	41.42	41.42
	Female	41	58.58	58.58	100
	Total	70	100	100	

**Graph 2:- Frequency graph of Gender class of respondents**

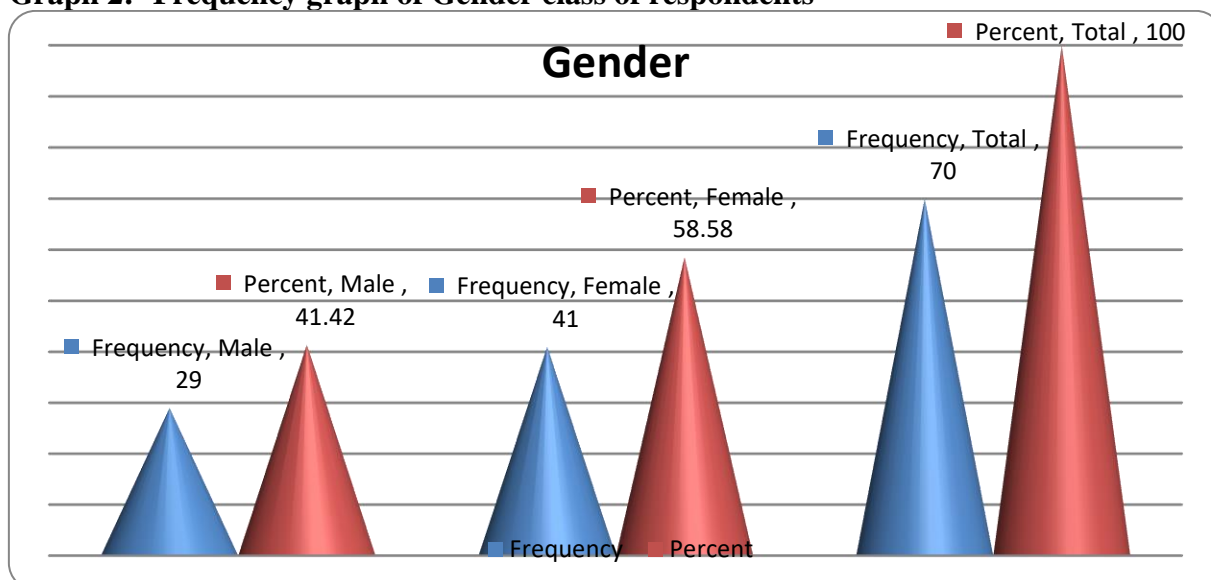

As the above table 2 and graph 2 shows, 58.58 % of the respondents in this graph are female which are made to be compared to male (41.42%). This clearly demarcates that and clearly shows that there are more number of females workers in the present scenario of the financial sector of Jaipur and Jodhpur while compared with the male workers. Today females are getting more and more independent and now are able to take their responsibility on their own.

**Table 3:- Frequency table of Education of respondents**

Educational Qualification					
	Educational Qualification	Frequency	Percent	Valid Percent	Cumulative Percent
Valid	Secondary and senior secondary	1	1.44	1.44	1.44
	Graduate	23	32.85	32.85	34.28
	Post graduate	34	48.57	48.57	82.85
	Diploma/degree holder	12	17.14	17.14	100
	Total	70	100	100	



**Graph 3:- Frequency graph of Education of respondents**

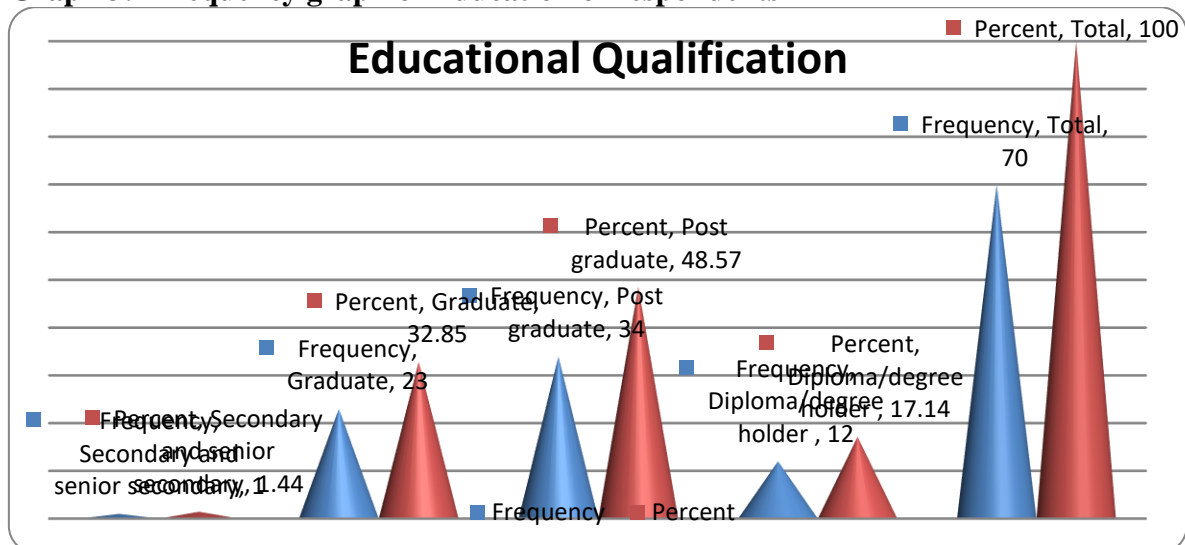

As per the table 3 and graph 3, the post graduate is 48.57 % of the total respondents which is highest and shows that today people are trying to be more and more educated. Bachelor degree holders are the 32.85% it is also a very good percentage of respondents, Diploma holders are 17.14%, secondary and higher secondary accounted 1.44% of the total 70 respondents which demarcates them from post graduate person who is having more knowledge.

**Hypothetical Testing**

H<sub>1</sub>: A significant relationship was found between training and development carry out which is being delivered to the employees and the employee performance after receiving the training.

**Table 4:- Anova**

Model	Sum of Squares	D F	Mean Square	F	Sig.
1 Regression	5.003	1	5.003	19.696	.003a
Residual	69.254	69	0.254		
Total	74.257	70			

**Table 5:- Coefficients**

Model	Unstandardized Coefficients		Standardized Coefficients	T	Sig.
	B	Standard error	Beta		
1 constant	1.253	.342		3.352	.000
Training	.206	.104	.283	2.934	.003

Dependent Variable:- employee performance

Independent Variable:- Training

In the given ANOVA table 5 shown above very clearly shows, the calculated significance which was found to be 0.003. This can be construed that the existing relationship which was found between training being provided to them and the employee performance on its basis is quite significant. Hence with this result it can be clearly stated that there is a

relationship which is existing between employee training being provided to them and employee performance.

This values calculated indicates that employee performance towards their work will surely increase by 0.206 for every one unit upsurge when found done in training. As considered that training is an important part of the organization. That is, however when employees are being trained by good trainers, their performance in an organization will gradually increase by 20.6%. The beta coefficient which is calculated by regression is found to be 0.283 positive. Hence it is evident that training given while joining has a strong and positive impact and has 28.3% influences on employees' job performance which is very high. Hence the hypothesis one which is done successfully and was proved to be significant accordingly.

H2: A significant relationship is present between Performance Appraisal of an employee and employee performance on its basis.

**Table 6:- ANOVA**

Model	Sum of Squares	D F	Mean Square	F	Sig.
Regression	10.263	1	10.263	10.861	.000a
Residual	65.201	69	0.945		
Total	75.464	70			

**Table 7:- Coefficients**

Model	Unstandardized Coefficients		Standardized Coefficients	T	Sig.
	B	Standard error	Beta		
1 constant	2.434	.237	10.133	.000	2.521
Training	.382	.081	.358	4.071	.000

Dependent Variable:- employee performance

Independent Variable:- Performance appraisal

The value of significant which was calculated of the model from ANOVA was found to be 0.000. This emits very strongly that the relationship which was existing between performance appraisal being generated and for the employee performance in an organization is statistically significant.

The coefficient value which was calculated for performance appraisal and employee performance, by using the method of regression equation  $y = b_1x_1 + a$ , and it was seen that the Employee Performance = 0.382 (Performance Appraisal) + 2.521. This clearly emits that the employee performance will steadily increase by 0.382 with every unit increase done in the performance appraisal of the same employee. As performance appraisal is very much required for an employee for the rewards and recognition.

The beta coefficient calculated or derived for performance appraisal and for the employee performance is 0.358. Calculated value of beta indicates how the two are affected on the basis of any changes in the two, the level at which independent variable (like that of performance appraisal) can really significantly influence the variations to be develop in the dependent variable (such as employee performance). The higher the calculated value of beta clearly demarcates the higher is the effect which is found to be left by an independent variable on the dependent variable and vice versa is also observed. Performance Appraisal when calculated has 35.8% influences on any of the employee performance which has been

calculated on the above basis. The percentage of influence by the employee performance appraisal is moderate and very less effective. This proves that performance appraisal of an employee leaves a moderate or very less impact on employees' performance in the organization of finance.

H3:- There is a significant relationship which was found between employee participation and employee performance in an organization.

**Table 8:- Anova**

Model	Sum of Squares	D F	Mean Square	F	Sig.
Regression	0.049	1	0.049	0.040	.603a
Residual	84.253	69	1.22105797		
Total	84.302				

**Table 9:- Coefficients**

Model	Unstandardized Coefficients		Standardized Coefficients	T	Sig.
	B	Standard error	Beta		
1 constant	3.063	.252	9.63	10.852	.000
Training	.024	.203	0.234	0.863	.507

Dependent Variable:- employee performance

Independent Variable:- Employee participation

From the ANOVA Table, the significance was tried to be done in proper manner for the relationship to be found between employee active participation and employee performance on this basis a test was done. It can be inferred or can be said after the result that these two are not related to each other, from this result it can be concluded that there is no relationship to be found existing between the independent variables (such as Employee Participation) and the dependent variable (which could be employee performance). In this it was clearly seen that both the independent and dependent variables of the table which are being taken are not comparable and fit with each other.

The coefficient value was being calculated for employee participation and employee performance, by the method of using the regression equation  $y = a + b_1X_1$  which can be further expressed as by the calculated values that the Employee Performance = 0.024 (Employee Participation) + 3.063. This model which was used for estimation and it was trying to show that the calculated employee performance is expected to increase by 0.024 when ever in case employee participation will increase by one unit and even the employee performance value is expected to be 3.063 when the incentives are taken as zero, as discussed clearly that employee performance by this should increase majorly but this cannot be always true or same in any condition.

The beta coefficient is positive at 0.234. The beta percentage which is calculated is 2.3% which can be thought to be very low and beyond the perception and hence not very effective. This proves or clearly states that the level of influence which is made by the employee participation on employee performance in an organization is comparatively very low. Hence it can be said that the H3 which was proved is to be non- significant. It can be concluded that employee participation was not effective in generating or modulating a true employee performance.

## **Conclusion**

This study was undertaken with the thought to have a basic and important objective of identifying properly or understanding the true impact or the result of various HR practices on the employee performance whether male or female in the financial sector which is very important from nations' development point of view. Three major HR practices are being chosen and were being discussed for study after review of literature related to HR practices and detail is being provided about conducting a study on HR practices at two cities of Rajasthan namely Jaipur and Jodhpur. Three hypotheses were generated on the basis of a study being done or developed which focused specifically on identifying the impact of Training being provided to the employees of the organization, performance appraisal and the active Employee participation which resulted in the efficient employee performance in an organization. The results of the reversion analysis which being done have significantly proved the theorem and showed that there was a significant and visible relationship seen between the training which was given to employees on the employee performance which was generated after the training. Along with this, it was also found that Performance appraisal which is prepared yearly has left a moderate visible impact on the performance of the employee and even also it is seen that employee participation towards any concern and its active involvement in any type of decision making has minimum influence which is being left on the employee performance in an organization.

## **References**

- ☞ Aguinis, H., 2009. Performance Management. 2 edition, Person education, Inc., publishing as Prentice Hall.
- ☞ Altarawmneh, I. and M.H. Al-Kilani, 2010. Human Resource Management and Turnover Intentions in the Jordanian Hotel Sector. *Research and Practice in Human Resource Management*, 18(1): 46-59.
- ☞ Armstrong, M. (2006). *A handbook of human resource management practice*. Kogan Page Publishers.
- ☞ Becker, B. E., & Huselid, M. A. (1998). Human resources strategies, complementarities, and firm performance. *SUNY Buffalo*.
- ☞ Brown, D., 2009. Rewards for fairness: How much bonus is enough? *Personnel Today*. Sutton, pp: 14.
- ☞ Chatterjee, S.R. and C.A.L. Pearson, 2000. "Work Goals and Societal Value Orientations of Senior Indian Managers: An Empirical Analysis," *Journal of Management Development*, 19(7): 643-653.
- ☞ Collins, C. J., & Clark, K. D. (2003). Strategic human resource practices, top management team social networks, and firm performance: The role of human resource practices in creating organizational competitive advantage. *Academy of Management Journal*, 46(6), 740-751.
- ☞ DeCotiis, T.A. and T.P. Summers, 1987. The Path Analysis of a Model of the Antecedents and Consequences of Organizational Commitment, *Human Relations*, 40: 445-470.
- ☞ Eisenberger, R., R. Huntington and D. Sava, 1986. Perceived Organizational Support. *Journal of Applied Psychology*, 71: 500-507.

- ☞ Gerhart, B., 1990. Gender differences in current and starting salaries: The role of performance, college major and job title. *Industrial and Labor Relations Review*, 43: 418-433.
- ☞ Guest D (2002). 'Human Resource Management, Corporate Performance and Employee wellbeing: Building the worker into HRM'. *The Journal of Industrial Relations* 44:3 335-358
- ☞ Harel, G. H., & Tzafir, S. S. (1999). The effect of human resource management practices on the perceptions of organizational and market performance of the firm. *Human Resource Management: Published in Cooperation with the School of Business Administration, The University of Michigan and in alliance with the Society of Human Resources Management*, 38(3), 185-199.
- ☞ Huselid M (1995). 'The Impact of human resource management practices on turnover, productivity, and corporate financial performance'. *Academy of Management journal* 38: 3 635-670
- ☞ MacDuffie, John Paul. "Human Resource Bundles and Manufacturing Performance: Flexible Production Systems in the World Auto Industry. *Industrial and Labor Relations Review*, in press
- ☞ Noe, R.A., J.R. Hollenbeck, B. Gerhart, P.M. Wright, 2007. *Human Resource Management: Gaining a competitive advantage*. USA: McGraw-Hill.
- ☞ Patterson, M., West, M., Lawthom, R. and Nickell, S. (1997). *Impact of People Management Practices on Business Performance*. London: Institute of Personnel Management.
- ☞ Sarbariya ,R., & Khita, A.R., (2011). *Human Resource Practices and It's Effect on Employee Job Satisfaction :A study on selected small and medium sized iron & steel firm in India public policy and administration research, vol.1, No.1.*
- ☞ Wood S (1999). 'Human Resource Management and Performance'. *International Journal of Management Reviews* 1: 4 367-413

## **The Effect Of Electronic Oral Message On Consumer's Purchase Behaviour**

**Jyoti Jhajhra\***

### **Introduction**

These days the conventional marketing processes have started losing their charm (Sweeney *et al.*, 2008). Mass media is omnipresent in today's world. Its influence is immense on people. Thus, the customers are widely exposed to different types of commercial advertisements. This has given an enormous opportunity for the customers to get information on varieties of products and services. Customer knowledge sharing in the virtual environment has been a popular research area in recent years (Rafaeli & Raban, 2005; Lee *et al.*, 2006). Information on different products make the customer's knowledgeable, who, then start sharing their knowledge and experience with others. This makes "word of mouth" another effective way to promote a product/service (Arndt, 1967). Word of mouth is considered one of the most dominant and effective forms of advertisements in the market. Word of mouth is an oral communication among customers, prospects, or simple visitors about the positive and negative experiences that the customers or the users of a product/service have received (Arndt, 1967). Word of mouth takes place only when the customers share their experiences with no commercial mentality (Sen & Lerman, 2007). The motivation behind this type of communication from the customers remains in the expression of an independent valuation of the product/service that the customer has experienced (Kozinets *et al.*, 2010).

Customers or prospects look for information from word of mouth when they intend to buy a product/service (King *et al.*, 2014). Thus, word of mouth communication is different from advertisements since word of mouth is completely a voluntary activity (Sen & Lerman, 2007).

The relationship that a firm keeps with its customers, is one of the prime factors behind the success and sustenance of the firm (Strutton *et al.*, 2011). The technological development, especially remarkable upgradations in information technology and the internet have changed the way customers and firms interact with each other (Chang *et al.*, 2005). Nowadays, customers are too much dependent on the social media channels. Hence, customers are no more passive recipients of marketing information; they take an active part in different discussions and forums. They are providing recommendations and sharing their own experiences or thoughts about different products and services (Das & Mandal, 2016). According to Gummerus (2012), people involved in word of mouth act more when they are more interested in a product/service. The customer firm relationship is often overlooked or ignored. Researchers opine that the existing firm-customer relationship offers huge economic benefits if it is managed efficiently (Jayachandran *et al.*, 2005).

Bhattacharya & Sen (2003) have proposed "customer-firm identification" where the researchers have opined that good customer-firm relationship leads to positive electronic oral message whereas cold relationship leads to negative electronic oral message. These researchers have further argued that in a strong customer-firm relationship, a customer may

---

\* (Research Scholar), Haryana School of Business, GJUS&T, Hisar, 125001



show more unfavorable or resilience if they get any negative information about the company (Bhattacharya & Sen, 2003). Hence, positive and negative electronic oral message is closely related to customer-firm relationship. The prime aim of this paper is to review the influence of electronic oral message valence on the buying behaviour of customers.

With the rapid proliferation of the internet, e-commerce, and social media, the relevance of word of mouth has been increasing by leaps and bounds. Even two decades before word of mouth existed when customers discussed a product/service when they met each other or contacted over the telephone but social media, email, and various other online forums have made word of mouth more effective than ever (Kozinets *et al.*, 2010). Customers can now access wide platforms to describe their experience and get the opinions of other customer. So, word of mouth has become electronic oral message and more powerful thanks to online platform. electronic oral message spreads the news more rapidly among different customers and people (Brown *et al.*, 2007). Hence, apart from market-oriented information on products and services, electronic oral message has been considered as a parallel process of advertisement.

In the view of Neti (2011), the internet has given a completely new platform to the customers where they can comfortably share their experience and wisdom as customers of different products and services. Electronic word of mouth (electronic oral message) is defined as “any positive or negative statement made by present or previous customers about a product, service or company, which is made available to large audiences via the Internet” (Abubakar *et al.*, 2016).

With the emergence of the internet, electronic oral message (electronic word of mouth) has become an important influence on customer's product evaluation. At the same time, social media has eased the communication process (Doh, 2011). According to Cheung & Thadani (2012), the traditional framework of word of mouth has changed significantly. Online word of mouth can be defined as any positive or negative information available on the internet generated by certain customer related to a product/service which is then brought to several individuals (Henning-Thurau *et al.*, 2004). Online customer reviews, functioning both as recommenders, are important in making purchase decisions and for product sales (D.H park, 2007.)

This type of online communication process can be termed as “electric word of mouth” or “electronic word of mouth” or “electronic oral message”. However, recent literature calls this “electronic word of mouth” and uses the abbreviation electronic oral message.

In the view of Brown *et al* (2007), though electronic oral message has evolved from word of mouth, it is distinct from the source in many aspects. electronic oral message spreads faster than word of mouth. Social media has been expanding fast where the customers can easily share their thoughts and experiences about a product/service very easily and it also reaches to the receivers very fast (Erkasn & Evans, 2016). Word of mouth has some geographical restrictions but the internet reaches everywhere, hence electronic oral message moves faster without any barrier. Many opinions and experiences of customers are visually supported in electronic oral message which is not possible in case of word of mouth. According to Erkan & Evans (2016), electronic oral message with video and images have been trending these days which make the messages more authentic and engaging. Electronic oral message, happens in different forms such as Instant Message, email, blogs, chat rooms, social networking, video conferencing, newsgroups, and review

sites, etc. (Vallejo, Redondo & Acerete, 2015). People here share opinions and write about their own experiences which help others in taking decisions (Hennig & Gianfranco, 2014). The relationship between the receiver and sender of electronic oral message message is one of the prime factors on customers purchase decision (Darban & Li, 2012). Thus, a stronger relationship makes a message more reliable and vice versa. The knowledge level of the sender of a message also plays a vital role in the impact of electronic oral message (Bansal & Voyer, 2000). As such, if the sender is assumed to be an authentic source then the receiver accepts the message more positively (Romani, 2006). Due to this reason, customers' opinions are valued over commercial advertisements. Moreover, a customer's attitude towards information also plays a vital role in the effectiveness of electronic oral message. Thus, electronic oral message information where customers show more interest is more impactful than that electronic oral message information which is distributed arbitrarily (Sweeney *et al.*, 2012).

Stauss (1997, 2000) discussed the threats and opportunities for businesses brought about by the rise in online customer articulations. Companies would, therefore, be wise to have channels to monitor the complaints of opinion leaders to avoid negative electronic oral message going viral. (Mahapatra & Mishra, 2017). In recent times, several studies have been done on the influence of electronic oral message on customer buying behaviour (Wallace *et al.*, 2009). According to Huang *et al.*, (2011) word of mouth is vital for the customers irrespective of being positive or negative. However, Sweeney *et al.*, (2012) suggests that in many situations, it is found that positive electronic oral message has more influence over the customers than negative word of mouth. On the contrary, there are other research works whose outcomes show that negative word of mouth is more influential than positive word of mouth (Arndt, 1967). The concept appears to be carrying different valence among researchers and experts. Moreover, with the changing nature of word of mouth its effect, positive and negative, has become stronger and act as antecedent to the customer's decision-making process.

### **Research Methodology**

The present study is a review of research papers from different sources addressing electronic oral message, and related issues published between year 1967 to 2017. The research papers and articles included in the study were published in high-end databases like Springer, Sage, Emerald Insight and others. The search items like 'electronic oral message', 'customer purchase intention', 'customer-firm relationship' were used.

Most papers on the combined areas of electronic oral message, customer purchase intention and customer-firm relationship have been published since 1967, with 2012 being the peak year. While comparing the period before the year 2000 with that of after the year 2000, it is revealed that this area of research has grown in recent years with the growing popularity of the internet. This may be because of the reason that people have now started showing the propensity towards electronic oral message as they are more curious to know each and every aspect of product and company.

### **Conclusion**

Findings indicate that positive and negative electronic oral message has an influence on purchase intention and customer-firm relationship. With the outrageous participation of today's customer over the internet, electronic oral message is becoming a need for customers and the decision makers. With growing importance of electronic oral message the researchers and marketers can't afford to skip the influence of electronic oral message

on customer decision making. It is essential to figure out where the current research stands on electronic oral message and where it is heading..

Several types of negative electronic oral message could be found in this context such as lower levels of agreement on what the others opine about the brand, higher reliability regarding word of mouth senders understanding regarding the brand, higher support for word of mouth sender's comparison of the brand with the other brands, etc. (Gopinath *et al.*, 2014). Several research works have also pointed out that a negative electronic oral message may not always develop a negative influence on the receivers of that electronic oral message (Hinz *et al.*, 2011). Linet *et al.*, (2012) conducted a scenario-based survey for getting an idea, how negative electronic oral message works for a service-based product and in that related market environment. The researchers concluded that a negative electronic oral message that has received higher consent from the receivers that contribute to higher reliability and distinctiveness, which is concerned to the service-based product. There are several studies with contradicting views regarding positive and negative electronic oral message. So, more in-depth empirical studies are necessary to find the consequences of electronic oral message valence.

The study of Martesen & Gronholdt (2016) has revealed that how the emotion and selection by the customers get affected by electronic oral message. Their research findings reveal that positive electronic oral message influences the buying behaviour and buying intention of the customers but negative electronic oral message has no significant impact on the buying behaviour of the customers, it has a trivial impact on the buying intention of the customers. The most interesting finding of this research is that the effect of positive electronic oral message is approximately two times more than the effect of social norms on the buyers' behaviour, and buying intention of the buyers.

Erkan & Evans (2016), have investigated the impact of electronic oral message on the purchase intention of the regular social media users and 384 college students were selected as participants and their conversations related to electronic oral message were examined. It was revealed that the attributes of electronic oral message like reliability, quality of the messages and the attitude of the customers toward exploring new products/services and knowing more about the product were found to have an immense impact on the customers' buying decision.

Moreover, several other studies have been conducted on the authenticity of the information passed through electronic oral message. According to Ho-Dacet *et al.*, (2014) electronic oral message can increase or reduce a customer's interest in a product/service which again influences the purchase intention of the customer. On the contrary, study of Huang *et al.*, (2011) found that electronic oral message messages don't have any significant impact on the purchase decisions of the customers. Weiberger & Dillon (1980) conducted a survey of 280 participants and in an artificial environment revealed that negative electronic oral message is more influential than positive electronic oral message. But, Sweeney *et al.*, (2012) study proposed an entirely opposite view and found that positive messages are more influential than the negative ones. They had conducted a 4-stage study where both qualitative and quantitative research methodologies for data collection were used. Hence, it is suggested that positive and negative information play essential roles in electronic oral message communication processes (Arndt, 1967). People these days spend a lot of time on social media which means lots of electronic oral message messages are created every day.

electronic oral message is very useful way of interaction which makes it more authentic and reliable means of exchanging opinions and making buying decision.

According to Kimiloglu & Zarali (2009), customer firm relationship (CFR) has become popular among the scholars in this field. The aim of CFR is to increase the brand loyalty among customers and also help a company to bring in revenue from prospect to lead customer, their journey is captured in CFR, in fact CFR helps in building strong relationship of a company with its customers. As, the bond between a company and their customers is immensely important (Bull, 2003). It is observed that maintaining an existing Customer-Firm relationship is less expensive than what it takes to acquire a new one (Phelps *et al.*, (2012).

According to Jayachandran *et al* (2005), customer retention can be directly linked to the improved marketing performance i.e. profit boost. Thus, any company with proactive approach pays more attention towards customer-firm relationship, which is why it has become an essential part of proactive company's marketing strategy. Owing to this fact, the companies, today, pay an enormous amount of time and money towards customer relationship management (Bull, 2003).

Latterly, it has been observed that the focus of research has been more towards maintaining good customer-firm relationships and that too with the help of information technology. Undoubtedly, customer firm relationship has undergone a revolution with advancement in technology especially because online platforms like social media help to intensify interactions with the customers and thus contribute to bring in revenue (Chang *et al.*, 2005). The internet as a medium offers many facilities like high speed, easy communication, cost-effective communication channels, and real-time interactions which has made it easy for both a company and their customers to interact with each other in more efficient way (Bauer *et al.*, 2002). According to Baird & Parasnis (2011), social media has helped the companies come closer to the customers and maintain good relationship. Moreover, it helps to tailor the way they respond to customer needs in a context of situation. Various upgraded technological features like data warehousing and data mining assist companies to gather customer-related data and use it to interact personally (Tan *et al.*, 2002). Hence, the internet acts a platform to build a strong customer relationship online unlike in its conventional approach. Today such an approach makes a customer feel more satisfied in terms of material as well as psychological needs which is the key forces driving strategy today (Bhattacharya & Sen, 2003). For example, there are word of mouth then usually prefer to buy cosmetics from a particular brand of their choice which not only gives them psychological satisfaction are also fulfill their functional needs. This example throws light on the importance of "customer-firm identification" model which is also known as C-R identification model (Bhattacharya & Sen, 2003). C-R identification can be defined as an elective, active, and volitional on customers' part that made them engaged in both favorable and unfavorable activities from a company's perspective. There are five obvious outcomes of C-R identification. However, the author proposed that "Resilience to negative information" and "Company promotion" need to be focused more. According to Hibbard *et al.*, (2003), a strong sense of identification with the firm drives a customer to overlook any negative information about the companies with which they are connected at psychological level. This characteristic correlates with the other factor of C-R identification, i.e. "Resilience to Negative Information".



Alsop (2002) argued that customers with strong relationship with the companies ignore the negative messages about those companies especially when such messages are of little relevance. However, in certain circumstances, customers may get involved in “uncomplimentary company-related behaviours”. That is, when the negative information is beyond the acceptable range like a news of company abusing their employees or employs child labor. In such situation the same customer who felt strongly associated to firm will think critically. But normally it is observed people react more to the negative messages related to social, ethical, and environmental issues (Bergami & Bagozzi, 2001). Hence, within a certain resilience level, high customer-firm relationship can restrain the negative information.

According to Bhattacharya & Sen (2003), the brand identification goes beyond mere satisfaction and help connect with customer at a psychological level. Thus, tapping their needs and fulfilling them which makes a customer stick to that brand as not only their desire is fulfilled but also that “sense of belonging”. Several other research works have also supported this view.

According to Gummerus *et al* (2012), main idea of customer getting engaged in electronic oral message help to strengthen their relationships with the brands. This concept goes beyond the common customer loyalty measures such as the frequency of visits, the frequency of inquiries, and buying behaviour of the customers. It is observed that customers with high identifications carry positive electronic oral message about the companies they feel associated to and can be called an anonymous “company promotion” process (Brown *et al*, 2005).

### **Conclusion And Research Gap**

In the review the researcher observed that electronic oral message is an extension of the well-established concept of word of mouth on the Internet platform. The traditional marketing approach is being revised and modified to utilize the power of the Internet. As now consumers have more power with them due to proliferation of social media and the Internet forums and communities.

Many consumers directly or indirectly make use of electronic oral message before making their final purchase. Consumers also use electronic oral message in post-purchase process to share product experiences and to voice their opinions. Different consumers have different motivations while participating in electronic oral message creation. They participate not only to provide first-hand reviews but help other buyers, discuss pros and cons of a product meant mainly for information sharing.

Electronic oral message is not only beneficial to customers but also help marketers in building product awareness, strengthening brand value, improving sales and other performance related parameters, and building customer loyalty. Infact, electronic oral message also acts as a direct feedback to marketers as they can use both positive as well as negative electronic oral message to improve their product/service deliveries and to offer recoveries and address consumer grievances.

With the advancement and penetration, technology is touching the lines of people closely across the globe. The customers have started depending upon the internet especially social media for any information. Nowadays people are not only getting the information from internet, but it has started to affect their purchase decision also. Thus, more and more researchers and marketers are interested in studying the influence of electronic oral message valence on the purchase intention that ultimately lead to purchases. It is found that

the influence of electronic oral message valence has a positive impact on customer purchase intention as positive electronic oral message is the most important factor influencing customer purchase intention and building customer firm relationship as people who are associated with certain company tend to ignore negative electronic oral message.

Technological breakthroughs, inventions, innovations of smart devices, Smartphone's, tablets, and other new ways of communication such as instant messaging apps on smartphones, are the new trends. These trends will have impact on how consumers and marketers will deal with electronic oral message. Thus, these new avenues will also provide the playground for future research in this area.

The Purpose of this research is to develop a comprehensive set of electronic oral message Attributes and customer-firm relationship that can be standardized and used in empirical research whose aim to increase researcher's understanding about the factors influencing customer purchase intention. electronic oral message not only strongly influences customer purchase intention but also validates that in a strong customer-firm relationship people tend to accept only the positive electronic oral message. The study's related to the effect of electronic oral message valence on customers' purchase intention have not much researched till now in India. But with the customer engaging more and more in social media, it has become important area of study. As such a research might help decision makers and marketers to understand electronic oral message and its valence and follow the best practice to maximize the electronic oral message approach.

This study has certain suggestions that can enable future research. First, the technological boom has opened future endeavours towards cultural influence which is an important factor impacting purchase intention. Henning & Barbara (2012) in their report concluded that among men and word of mouth, men are more viral video mavens. Thus, it raises an important question that can similar outcome be expected in context to electronic oral message? Such a question can be interesting avenue for future research aiming to test the gender differential response on purchasing intention. Lastly, situational factors such as a customer's mood and emotions may also influence customer intention to react to electronic oral message.

### **References**

- Abubakar, A. M., Ilkan, M., & Sahin, P. (2016). eWOM, E-referral and gender in the virtual community. *Marketing Intelligence & Planning*, 34(5), 692-710.
- Arndt, J. (1967). Role of product related conversations in the diffusion of a new product. *Journal of Marketing Research*, 4(3), 291-295.
- Bansal, H. & Voyer, P. (2000). Word-of-mouth processes within a services purchase decision context. *Journal of Service Research*, 3(2), 166-177.
- Berger, J., Sorensen, A. T., & Rasmussen, S. J. (2010). *Positive effects of negative publicity: When negative reviews Increase Sales*. *International Journal of Marketing Science*, 29(5), 815-827.
- Bhattacharya, C. & Sen, S. (2003). Customer company identification: A framework for understanding customers' relationships with companies. *Journal of Marketing*, 67(2), 76-88.
- Bickart, B. & Schindler, R. (2001). Internet forums as influential sources of customer information. *Journal of Interactive Marketing*, 15(3), 31-40.



- Brown, J., Broderick, A. & Lee, N. (2007). Word of mouth communication within online communities: Conceptualizing the online social network. *Journal of Interactive Marketing*, 21(3), 2-20.
- Chang, T., Liao, L. & Hsiao, W. (2005). An empirical study on the E-CRM performance influence model for service sectors in taiwan. Proceedings of the 2005 International Conference on e-Technology, e-Commerce, and e-Service (IEEE'05), 240-245.
- Cheah, I., Phau, I. & Liang, J. (2015). Factors influencing customers' attitudes and purchase intentions of e-deals. *Marketing Intelligence and Planning*, 33(5), 763-783.
- Cheung, C. M. & Lee, M. K. (2012). What drives consumers to spread electronic word of mouth in online Consumer-opinion Platforms? *Decision Support Systems*, 53(1), 218-225.
- Cruz, D., & Fill, C. (2008). Evaluating Viral Marketing: Isolating the Key Criteria. *Marketing Intelligence & Planning*, 26(7), 743-758.
- Darban, A. & Li, W. (2012). The Impact of Online Social Networks on Customer's Purchase Decision---The Study of Food Retailers. M.A. Dissertation. Jönköping, Sweden: Jönköping International Business School.
- Das, P. & Mandal, S. (2016). Evaluating the influence of social media on brand sacralization. *South Asian Journal of Global Business Research*, 5(3), 424-446.
- Farhangi, A., Abaspour, A., Farahani, S. & Ghasemi, R. (2014). Analyzing the impact of social media on customer attitudes toward the brand and their intentions to purchase. *Global Media Journal: Persian Edition*, 9(2), 68-73.
- Gilly, M. C., Graham, J. L., Wolfinbarger, M. F., & Yale, L. J. (1998). A dyadic study of interpersonal information search. *Journal of the Academy of Marketing Science*, 26(2), 83-100.
- Gopinath, S., Thomas, J. S. & Krishnamurthi, L. (2014). Investigating the relationship between the content of online word of mouth, advertising, and brand performance. *Marketing Science*, 33(2), 241-258.
- Gummerus, J., Liljander, V., Weman, E. & Pihlström, M. (2012). Customer engagement in a facebook brand community. *Management Research Review*, 35(9), 857-877.
- Hennig, D., & Phillips, B. J. (2012, January). Understanding viral video mavens. In American Academy of advertising. Conference. Proceedings (Online) (p. 139). American Academy of Advertising.
- Hennig, T. & Gianfranco, W. (2014). Electronic word-of-mouth: motives for and consequences of reading customer articulations on the internet. *International Journal of Electronic Commerce*, 8, 51-74.
- Hinz, O., Skiera, B., Barrot, C., Becker, J. U. (2011). Seeding strategies for viral marketing: An empirical comparison. *Journal of Marketing*, 75(6), 55-71.
- Ho, J. Y., & Dempsey, M. (2010). Viral marketing: motivations to forward online content. *Journal of Business research*, 63(9-10), 1000-1006.
- Ho-Dac, N. N., Carson, S. J. & Moore, W. L. (2013). The effects of positive and Negative online customer reviews: Do brand strength and category maturity matter? *Journal of Marketing*, 77(6), 37-53.

- Hong, I. & Cho, H. (2011). The impact of customer trust on attitudinal loyalty and purchase intentions in b2ce-marketplaces: intermediary trust vs. seller trust. *International Journal of Information Management*, 31(5), 469-479.
- Huang, M., Cai, F., Tsang, A. & Zhou, N. (2011). Making your online voice loud: The critical role of WOM information. *European Journal of Marketing*, 45(7-8), 1277-1297.
- Jayachandran, S., Sharma, S., Kaufman, P. & Raman, P. (2005). The role of relational information processes and technology use in customer relationship management. *Journal of Marketing*, 69(4), 177-192.
- Jimenez, F. R., Mendoza, N. A. (2013). Too popular to ignore: The influence of online reviews on purchase intentions of search and experience products. *Journal of Interactive Marketing*, 27(3), 226-235.
- Kimiloglu, H. & Zarali, H. (2009). What signifies success in ecrm? *Marketing Intelligence and Planning*, 27(2), 246-267.
- King, R. A., Racherla, P., & Bush, V. D. (2014). What we know and don't know about online word-of-mouth: A review and synthesis of the literature. *Journal of Interactive Marketing*, 28(3), 167-183.
- Kozinets, R., de Valck, K., Wojnicki, A., & Wilner, S. (2010). Networked narratives: Understanding word-of-mouth marketing in online communities. *Journal of Marketing*, 74(2), 71-89.
- Lin, M. Y., Lu, K. Y. & Wu, J. J. (2012). The effects of visual information in eWOM communication. *Journal of Research in Interactive Marketing*, 6, 7-26.
- Lovett, M. J., Peres, R. & Shachar, R. (2013). On brands and word of mouth. *Journal of Marketing Research*, 50(4), 427-444.
- Mahapatra, S., & Mishra, A. (2017). Acceptance and forwarding of electronic Word of Mouth. *Marketing Intelligence & Planning*, 35(5), 594-610.
- Martensen, A. & Gronholdt, L. (2016). The effect of word-of-mouth on consumer emotions and choice: findings from a service industry. *International Journal of Quality and Service Sciences* 8, 298-314.
- Neti, S. (2011). Social media and its role in marketing. *International Journal of Enterprise Computing and Business Systems*, 1(2), 1-15.
- Park, D. H., Lee, J., & Han, I. (2007). The effect of on-line consumer reviews on consumer purchasing intention: The moderating role of involvement. *International journal of electronic commerce*, 11(4), 125-148.
- Pfeffer, J., Zorbach, T., Carley, K. M. (2014). Understanding online fire storms: Negative word-of-mouth dynamics in social media networks. *Journal of Marketing Communications*, 20(1-2), 117-128.
- Phelps, J. E., Lewis, R., Mobilio, L., Perry, D., & Raman, N. (2004). Viral marketing or electronic word-of-mouth advertising: Examining consumer responses and motivations to Pass along email. *Journal of advertising research*, 44(4), 333-348.
- Rafaeli, S., & Raban, D. R. (2005). Information sharing online: a research challenge. *International Journal of Knowledge and Learning*, 1(1-2), 62-79.
- Romani, S. (2006). Price misleading advertising: Effects on trustworthiness toward the source of information and willingness to buy. *Journal of Product and Brand Management*, 15(2), 130-138.

- Rust, R. T., Keiningham, T., Donthu, N., Hammedi, W., Blazevic, V., & Carl, W., et al. (2013). Beyond traditional word-of-mouth: An expanded model of customer-driven influence. *Journal of Service Management*, 24(3), 294-313
- Schultz, P. W., Gouveia, V. V., Cameron, L. D., Tankha, G., Schmuck, P., & Franěk, M. (2005). Values and their relationship to environmental concern and conservation behaviour. *Journal of cross-cultural psychology*, 36(4), 457-475.
- Sen, S. & Lerman, D. (2007). Why are you telling me this? An examination into negative customer reviews on the Web. *Journal of Interactive Marketing*, 21(4), 76-94.
- Stauss, B. (1997). Global word of mouth: Service bashing on the internet is a thorny issue. *Marketing Management*, 6(3), 28.
- Stauss, B. (2000). Using new media for customer interaction: A challenge for relationship marketing. In relationship marketing (pp.233-253). Springer, Berlin, Heidelberg.
- Strutton, D., Taylor, D. G., & Thompson, K. (2011). Investigating generational differences in e-WOM behaviours. *International Journal of Advertising*, 30(4), 559-586
- Sweeney, J., Soutar, G. & Mazzarol, T. (2012). Word of mouth: Measuring the power of individual messages. *European Journal of Marketing*, 46(1-2), 237-257.
- Thøgersen, J., & Ölander, F. (2002). Human values and the emergence of a sustainable consumption pattern: A Panel Study. *Journal of economic psychology*, 23(5), 605-630.
- Vallejo, J. M., Redondo, Y. P. & Acerete, A. U. (2015). The Characteristics of electronic word-of-mouth and its influence on the intention to repurchase online. *European Journal of Business Management*, 24(1), 61-75.
- Wallace, D., Walker, J., Lopez, T. & Jones, M. (2009). Do word of mouth and advertising messages on social networks influence the purchasing behaviour of college students? *Journal of Applied Business Research*, 25(1), 101-110.

## **Shareholder Value and Its Key Drivers: A Theoretical Review**

**Ms. Varsha Maheshwari\***

**Dr. Tapan K. Bhadviya\*\***

### **Abstract**

With increasing pressure on firms to deliver shareholder value, there has been a renewed emphasis on devising measures of corporate financial performance to increase shareholder wealth. A shareholder value review is projected the best way for boards of directors to explain to shareholders how the board monitors management's performance in maximizing shareholder value. A company creates value for the shareholders when the shareholder return exceeds the required return to equity. In other words, a company creates value in one year when it outperforms expectations. In this paper, we will define and analyze shareholder value creation and its key drivers. This paper attempts to provide a synoptic survey of SHV's conceptual underpinnings. To obtain the shareholder value, we must first define the increase of equity market value, the shareholder value added, the shareholder return, and the required return to equity.

**Key Words:-** Shareholder Value, Return on equity, Shareholder Value drivers

### **1. Introduction**

Now a day's creating shareholder value is at boom and became important goal of a company. Past studies illustrated that just only one seventh of companies are able to create long term shareholder value. Now large literature supports the shareholder value approach. For Fernandez (2001), when the shareholder return exceeds the cost of capital than company creates value for the shareholders. In other words, a company creates value in one year when it outpaces expectations. Rappaport (1987) has suggested the value drivers as growth rate, income tax rate, operating profit margin, fixed capital investment, cost of capital, working capital investment.

Srivastava et al. (1998) advise that value of firm is driven by growing the cash flows, and it can be through reducing the volatility and susceptibility of cash flows. Stewart (1991) has acknowledged six shareholder value drivers i.e. net operating profits after taxes, the tax benefit of debt in respect of capital structure, the amount of new capital invested, the after-tax rate of return of the new capital investments, the cost of capital for business risk and the future period of time over which the company return in excess of cost from new investments.

Fiordelisi (2007) by examining industry and macroeconomic specific determinants of SHV creation of European bank concluded that such factor have both positive and negative effects on SHV. Author concluded with main finding that income diversification, cost and revenue efficiency have shown positive relationship on SHV. Authors also examined

---

\* **Assistant Professor**, Master of Management Studies, University of Mumbai, Vidyalankar Institute of Technology, Wadala (E), Mumbai, Maharashtra, India

\*\* **Associate Professor**, Deptt. of ASBT, Mohanlal Sukhadia University, Govt. Girls College, Nathdwara, Rajsamand, India

different determinants of SHV creation like income diversification, cost management, credit risk taking and structure out of all this cost management and credit risk taking are only significant driver of SHV in banks because increase in credit risk taking destroy value while increase in cost efficiency creates it.

Author concluded that MVA is better indicator of SHV creation in comparison to Market Adjusted Return. From result it was found that in explaining shareholder value creation accounting-based variables (EPS, ROA and NOPAT) are superior to economic-based variables (EVA and ROCE) but it depend upon dependent variable chosen for measuring SHV. Industry to Industry there are different set of variables which determine SHV like the industrial goods industry has seven significant value drivers i.e. EPS, NOPAT, ROCE, the Spread, EVA, EBEI and REVA, whereas for the food and beverages industry there were only two significant value drivers (EPS and ROA). So it is suggested to management, analysts and shareholders while making investment decision should consider specific set of variable considering industry in which firms operate. Rappaport (1986) recommended seven drivers which create value in a business : i) sales growth ii) rise in the operating profit margin, iii) a reduction in the cash tax rate, iv) a reduction in the working capital investment, v) a reduction in the fixed asset investment; vi) a reduction in the weighted average cost of capital; vii) an increase in the competitive advantage period.

The findings reveal that diversified income, efficient cost management and high lending spreads in general, all increase SHV significantly. Taking into account the branch network samples, the income diversification variable doesn't seem to be significant for small-sized branches. In contrast, high credit risk expressed in accumulated loan impairments destroys value substantially. The income diversification variable doesn't seem to be significant for small-sized branches. In contrast, high credit risk expressed in accumulated loan impairments destroys value substantially. SHV literature supports the findings as regards diversified income (Cipollini and Fiordelisi, 2012; Fiordelisi and Molyneux, 2010), credit risk (Gross, 2006) and cost management (Fiordelisi and Molyneux, 2010; Gross, 2006). The result for the impact of income diversification is somewhat different from the findings of Dietrich and Wanzenried (2010) due to differences in the commercial banking structure of Greece and Switzerland. Also, the findings for credit risk and cost management are in line with the results of Athanasoglou, Brissimis and Delis (2008) who investigated profitability determinants for the Greek banking sector.

Author have mention only three key drivers of value creation i.e. The profitability of firm, measured by its ROIC i.e after tax return on capital invested secondly is the weighted average cost of capital of the firm and thirdly growth rate of the firm. From the findings of author MVA is a wealth metric which is positively related to EVA and as a performance metric it measures economic profit created by the corporate and is properly paralleled to accounting profit. Various researches are there in support of EVA as a best driver of share value added. Till EVA concept was introduced, cost of capital was never calculated when deriving profits it was free. And this gap was identified and addressed properly through EVA concept. Author has categorized value drivers in three Levels. First Generic value drivers which are typical return on the invested capital tree (ROIC), comprising operating margins and invested capital. The second level of value drivers is business-unit level drivers, which includes customer mix, sales force productivity or cost allocations variables and the last level is operating level where variables such as percentage of capacity utilize,



Year	Author Name	Excerpts	Remarks
1986 and 1987	Rappaport	Using the value drivers, the future cash flows can be forecast within the period. This period for an organization depends on for how far into the future the company expects to be able to add value above its weighted average cost of capital (WACC).	On the basis of accounting determined six value drivers which have effect on shareholder value
1998	Srivastava et al.	Action needs to be taken to manage and improve the value drivers.	Major emphasis was on Cash flow as value driver in determining SHV of company
2001	Fernandez	Company outperforms or creates shareholder value when it exceeds shareholder expectation by earning more than cost.	Informed about the measure which calculate shareholder value
2005	J.HvH. de Wet	Both EVA and Traditional measures were discussed and defined the importance in deriving value of firm.	Variables determining a company's value can be expressed using different levels
2006	Gross	Defined determinants of value specific to Banking industry	Discussed various drivers of creating shareholder value in banking sector and which driver have more impact on value is discussed.
2007	Fiordelisi	Studied macro economic and industry specific determinants of value creation	From study author shown both positive and negative impact of value drivers in creating value.
2008	Srivastava R and Mishra A	Several Value based management styles have been suggested each of which identifies key driver of value and uses a measurement tool based on cash flows and cost of capital.	The traditional process of valuation ignores aspirations of the shareholders. Most of value measures are cash flow based and incorporated capital cost. One of the most popular measures of value is EVA.
2015	Chandra Prasanna	Value Creation drivers	
2007	Khan & Jain (5th edition)	Defined different types of firms value and identified 4 approach for valuation of business with focus on equity share valuation i.e. asset based earning based on market value based fair value method.	Highlighted various drivers of Shareholder value creation in company. Discussed MVA & EVA approach to measure value with focus on shareholders.
2002	Fernandez Pablo	Level of value drivers	Covered the basics of valuation methods and shareholder value creation in addition to rigorous approaches to discounted cash flow valuation and real options for valuing



			a company.
2015	Madhavi E , Prasad MSV	recommended to asses corporate performance by valued added measures i.e. EVA	Defined both traditional and new performance measures which should be used by companies for valuation keeping interest of shareholders in mind.

cost per delivery and debtors or creditors terms and timing are well-ordered and improved by the decisions of managers.

## 2. Conclusion

Conclusion can be drawn from the review literature supported by various authors that value is created when the expected return spread is positive. It is all future stream of expected return spreads as well as growth is creating value only when expected return spread is positive i.e.  $ROIC > WACC$ . Thus ROIC can be increased by improving operating profit margin, increase in capital turnover and effective tax rate is decreased. Not only the traditional measures play important role but modern measure are best external measures of company's performance. EVA & MVA represents stock market's assessment of firm's performance and its ability to sustain in the market in the long run, closely observing if value has been created or destroyed by the firm over a period of time. Thus it is highly recommended that both EVA and other conventional accounting measures together be used in assessing the financial health of the companies.

## Bibliography

1. Athanasoglou, P.; Brissimis, S., and Delis, M. 2008. Bank specific, industry specific and macroeconomic determinants of bank profitability. *Journal of International Financial Markets, Institutions and Money*, 18:121-136
2. Cipollini and Fiordelisi, (2012) "Economic value, competition and financial distress in the European banking system", *Journal of Banking & Finance*, Vol. 36, Issue: 11, pp. 3101-3109
3. Fernandez, Pablo (2001), "A Definition of Shareholder Value Creation". SSRN
4. Fiordelisi, F. (2007) 'Shareholder value efficiency in European banking', *Journal of Banking & Finance*, Vol. 31, Issue: 7, pp. 2151-2171
5. Gross, S. (2006) "Banks and Shareholder Value. An overview of Bank Valuation and Empirical Evidence on Shareholder value for Banks." Frankfurt: DUV Gabler Edition Wissenschaft.
6. Michael L. Blyth, Elizabeth A. Friskey, Alfred Rappaport, (1986) "Implementing The Shareholder Value Approach", *Journal of Business Strategy*, Vol. 6 Issue: 3, pp.48-58
7. Rappaport, A. (1987) "Linking Competitive Strategy And Shareholder Value Analysis", *Journal of Business Strategy*, Vol. 7 Issue: 4, pp.58-67
8. Srivastava et al. (1998), "Market-Based Assets and Shareholder Value: A Framework for Analysis", *Journal of Marketing*, Vol. 62, pp.2-18

## Website

1. [www.sternstewart.com/](http://www.sternstewart.com/)
2. [www.shareholdervalue.com/indexIE.htm](http://www.shareholdervalue.com/indexIE.htm)
3. [www.valuecreationgroup.com](http://www.valuecreationgroup.com)

## **International Journal of Management, IT & Engineering**

Vol. 8 Issue 6(1), June 2018,

ISSN: 2249-0558 Impact Factor: 7.119

Journal Homepage: <http://www.ijmra.us>, Email: [editorijmie@gmail.com](mailto:editorijmie@gmail.com)

Double-Blind Peer Reviewed Refereed Open Access International Journal - Included in the International Serial Directories Indexed & Listed at: Ulrich's Periodicals Directory ©, U.S.A., Open J-Gate as well as in Cabell's Directories of Publishing Opportunities, U.S.A

---

4. [www.valuebasedmanagement.net/](http://www.valuebasedmanagement.net/)
5. Stern Stewart, [www.eva.com](http://www.eva.com)